

3SM221NMT1KA MEMS Microphone IC

Product Description

The *3SM221NMT1KA* microphone IC are integrated with specialized pre-amplification & analog-to-digital converter ASIC to provide high SNR output from a capacitive audio sensor. It's packaged for surface mounting and high temperature reflow assembly. *3SM221NMT1KA* is ideal in many compact portable consumer electronic devices such as Notebook, TV, Smart Speaker.

Features

- Top port
- High stability - no risk of membrane aging
- Suitable for automatic pick-and-place handler and SMT process
- Pulse density modulator (PDM) output interface supports two microphones on a single data line
- Miniature dimension 4.00mm x 3.00mm x 1.00mm
- RoHS/Green compliant
- Sensitivity deviation within ± 1 dB
- Package type : LGA 8-pin
- Omnidirectional

Applications

- Notebooks
- TVs
- Smart Speakers
- IoT Devices

Table of Contents

Product Description	P.1
Features	P.1
Applications	P.1
Table of Contents.....	P.2
Functional Block Diagram.....	P.3
Pin Definition and Function	P.3
Temperature Range.....	P.3
Acoustical and Electrical Characteristics.....	P.4
Timing Characteristics.....	P.6
Frequency Response.....	P.7
Performance Curves.....	P.8
State Diagram.....	P.9
Reliability Qualifications	P.10
Reflow Profile	P.11
PCB Land Pattern Layout	P.12
Application Circuit	P.13
Handling Instructions	P.14
Dimensions	P.15
Package Information.....	P.16
Revision History.....	P.19

Functional Block Diagram

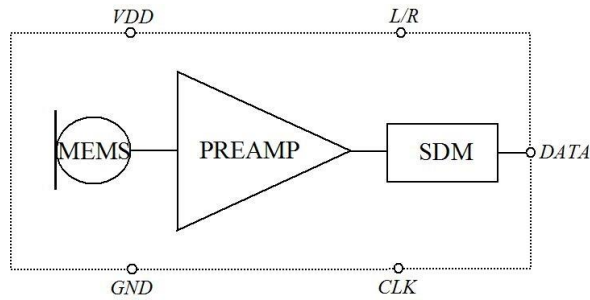

Pin Definition and Function

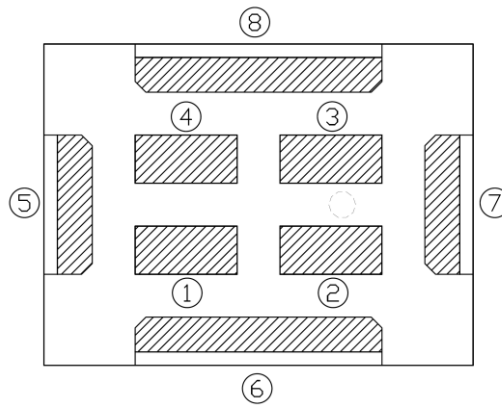

Bottom View

Table 1.

Pin #	Symbol	Type	Function
1	DATA	Digital O	Digital Output Signal
2	CLK	Digital I	Clock Input to Microphone
3	L/R	Non-Digital I	Left(Low) / Right(High) Select Pin
4	VDD	Power	Power Supply
5	GND	Power	Ground
6	GND	Power	Ground
7	GND	Power	Ground
8	GND	Power	Ground

Temperature Range

Table 2.

Storage Temperature	T _{STG}	-40°C ~ 125°C
Operating Temperature Range	T _A	-40°C ~ 105°C

Acoustical and Electrical Characteristics

Table 3. General Microphone Specifications

Typical test conditions are TA = 23 °C, VDD = 1.8V and R.H. = 50 % measured in a pressure chamber test setup. All voltages refer to GND node

Parameters	Symbol	Min.	Typ.	Max.	Unit	Test Conditions
Supply Voltage	Vdd	1.6		3.6	V	
Low Frequency Roll-off	LFRO		10		Hz	-3dB relative to 1KHz
High Frequency Flatness			13		kHz	+3dB relative to 1KHz
Resonant Frequency Peak			24		kHz	
Output Load	C _{Load}			100	pF	
Wake-up Time			50		ms	Fclk ≥ 1MHz
Startup Time			50		ms	
Sleep Time			1		ms	Fclk ≤ 1KHz
DC Offset		-3.2		0.3	%FS	Fullscale = ±100
Data Format	1/2 Cycle PDM					
Directivity	Omnidirectional					
Polarity	Increasing density of 1's					Increasing sound pressure

Table 4. Performance Mode Microphone Specifications

Typical test conditions are TA = 23 °C, VDD = 1.8V, Clock=2.4MHz and R.H. = 50 % measured in a pressure chamber test setup. All voltages refer to GND node

Parameters	Symbol	Min.	Typ.	Max.	Unit	Test Conditions
Acoustic						
Sensitivity	S	-27	-26	-25	dBFS	1KHz, 94dB SPL
Signal to Noise Ratio	S/N		67		dB	A-weighted
Equivalent Noise Level	ENL		27		dB	A-weighted
Total Harmonic Distortion	THD		<0.2		%	94dB SPL @ 1KHz
			1		%	110dB SPL @ 1KHz
Acoustic Overload Point	AOP		120		dB SPL	10% THD @ 1KHz, S = Typ.
Electrical						
Clock Frequency	Fclk	1.0		4.8	MHz	
Current Consumption	Isb		1150		μA	Vdd=1.8V
			1250		μA	Vdd=3.6V
Power Supply Rejection Ratio	PSRR		70		dBV/FS	1KHz, 200mV peak to peak sine wave
Power Supply Rejection	PSR+N		-90		dBFS (A)	217Hz, 100mV 1/8 duty cycle peak to peak square wave

Table 5. Low-Power Mode Microphone Specifications

Typical test conditions are $T_A = 23\text{ }^\circ\text{C}$, $V_{DD} = 1.8\text{V}$, $\text{Clock} = 768\text{KHz}$ and $R.H. = 50\%$ measured in a pressure chamber test setup. All voltages refer to GND node

Parameters	Symbol	Min.	Typ.	Max.	Unit	Test Conditions
Acoustic						
Sensitivity	S	-27	-26	-25	dBFS	1KHz, 94dB SPL
Signal to Noise Ratio	S/N		67		dB	A-weighted
Equivalent Noise Level	ENL		27		dB	A-weighted
Total Harmonic Distortion	THD		<0.2		%	94dB SPL
			1		%	110dB SPL
Acoustic Overload Point	AOP		120		dB SPL	10% THD@1KHz, S = Typ.
Electrical						
Clock Frequency	Fclk	350		800	KHz	
Current Consumption	Isb		400		μA	Vdd=1.8V
			450		μA	Vdd=3.6V
Power Supply Rejection Ratio	PSRR		70		dBV/FS	1KHz, 200mV peak to peak sine wave
Power Supply Rejection	PSR+N		-90		dBFS (A)	217Hz, 100mV 1/8 duty cycle peak to peak square wave

Table 6. Sleep Mode Microphone Specifications

Typical test conditions are $T_A = 23\text{ }^\circ\text{C}$, $V_{DD} = 1.8\text{V}$, $\text{Clock} = 0\text{Hz}$ and $R.H. = 50\%$ measured in a pressure chamber test setup. All voltages refer to GND node

Parameters	Symbol	Min.	Typ.	Max.	Unit	Test Conditions
Clock Frequency	Fclk	0		250	KHz	
Current Consumption Sleep Mode	Isleep		10		μA	Clock = VDD or GND

Timing Characteristics

Table 7. Microphone Interface Specifications

Parameters	Symbol	Min.	Typ.	Max.	Unit	Test Conditions
Logic Input High	V_{IH}	0.65x VDD		3.6	V	
Logic Input Low	V_{IL}	-0.3		0.35x VDD	V	
Logic Output High	V_{OH}	VDD -0.45		VDD	V	$I_{out} = 1\text{mA}$
Logic Output Low	V_{OL}	0		0.45	V	$I_{out} = 1\text{mA}$
Clock Frequency	F_{clock}			250	KHz	Sleep Mode
		350		800		Low-Power Mode
		1.0		4.8	MHz	Performance Mode
Clock Duty Cycle		40		60	%	
Clock Period for Normal Mode	T_{cyc}	208		1000	ns	
Data Setup Time	T_{dv}			100 ⁽¹⁾	ns	
Data Hold Time	T_{hold}	3 ⁽¹⁾			ns	

(1). Guaranteed by design

Timing Waveforms

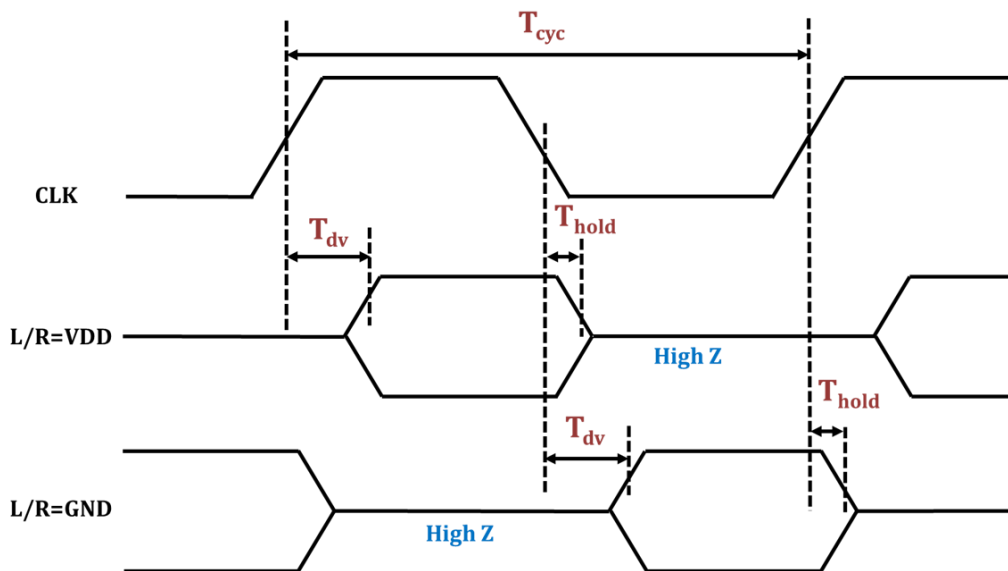

Frequency Response

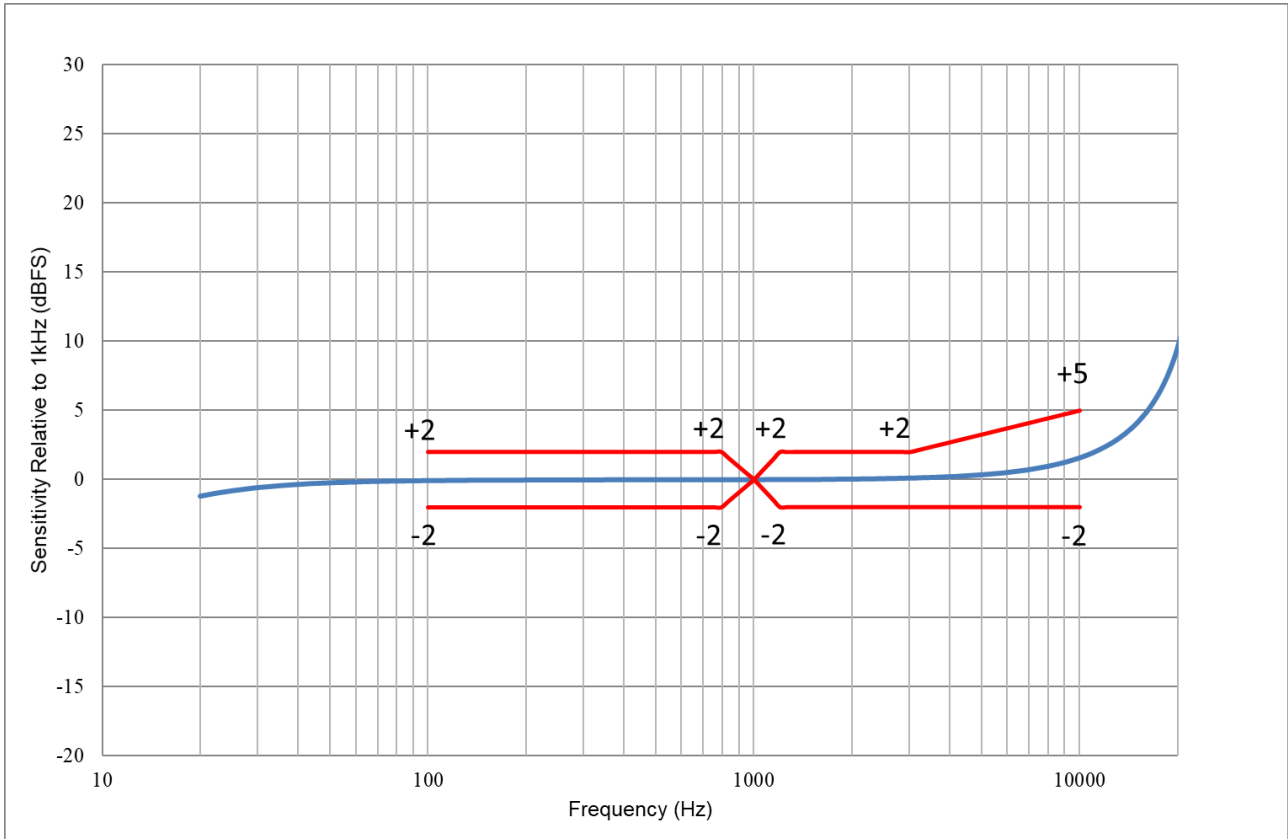

* Measured frequency of 1 KHz

Upper Limit						
Hz	100	800	1000	1200	3000	10000
dB ref. 1KHz	+2	+2	0	+2	+2	+5
Lower Limit						
Hz	100	800	1000	1200	3000	10000
dB ref. 1KHz	-2	-2	0	-2	-2	-2

Performance Curves

Typical test conditions are $TA = 23\text{ }^{\circ}\text{C}$, $VDD = 1.8\text{V}$ and $R.H. = 50\%$, output unloaded

Typical THD vs Input SPL

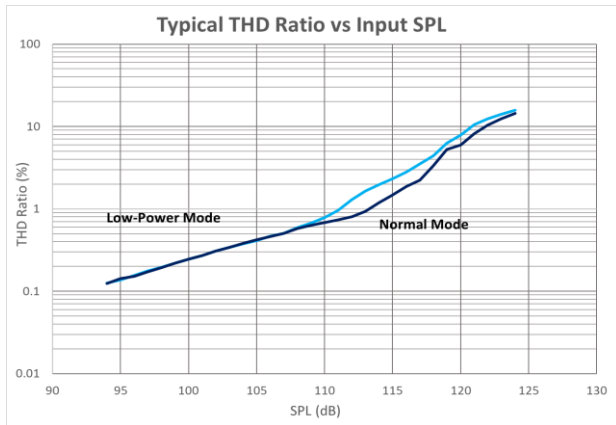

Typical Idd vs Vdd

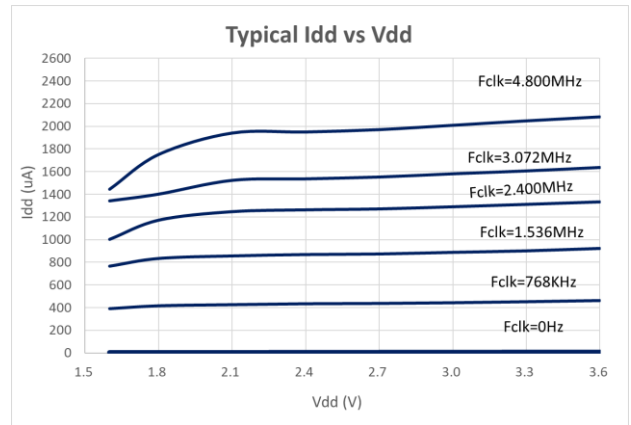

Noise Floor Power Spectral Density

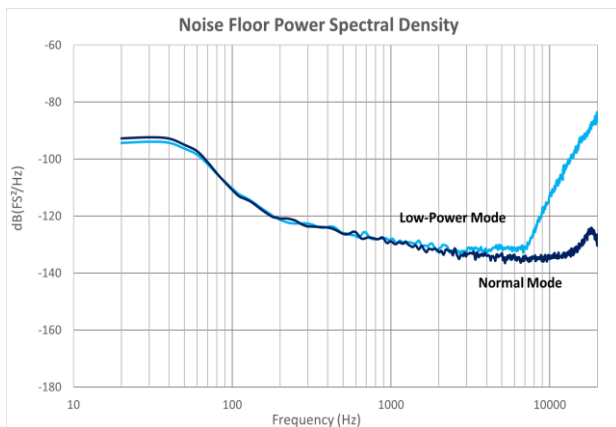

Typical PSRR vs Frequency

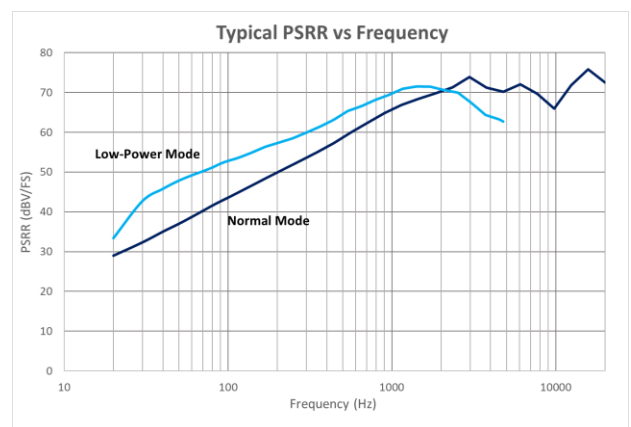

State Diagram

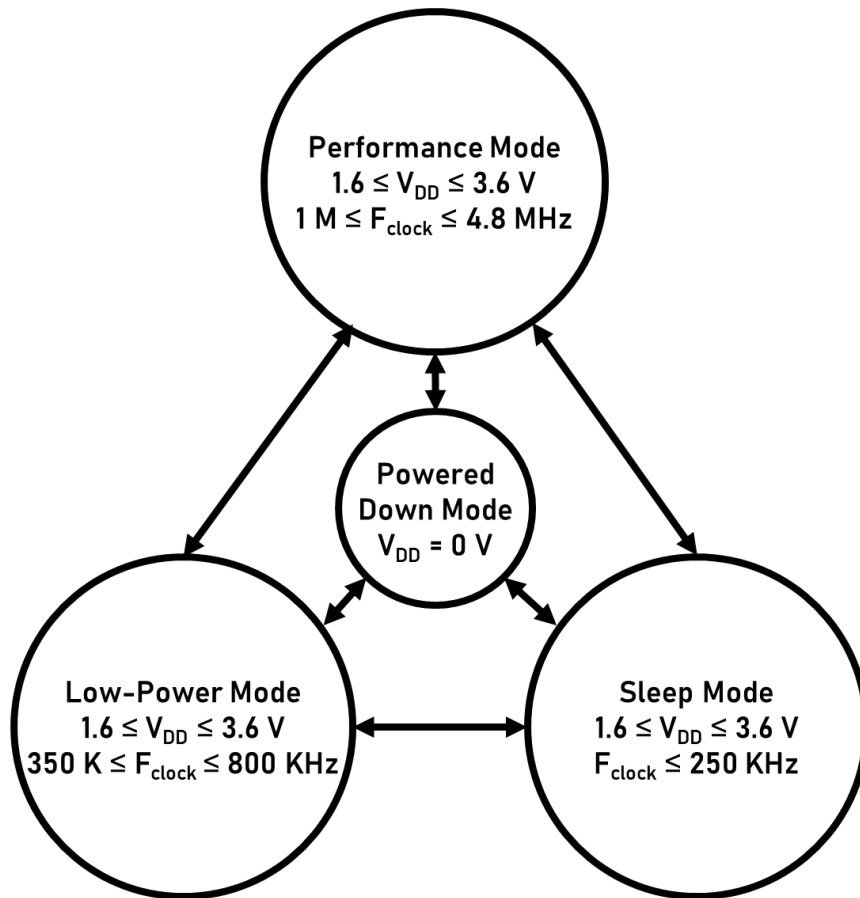

Reliability Qualifications

Table 8.

Test Item	Description
High Temperature Storage	Storage at 125°C for 1,000 hours JESD22-A103
Low Temperature Storage	Storage at -40°C for 1,000 hours JESD22-A119
High Temperature Operation Bias	Under Bias at 105°C for 1,000 hours JESD22-A108
Low Temperature Operation Bias	Under Bias at -40°C for 1,000 hours JESD22-A108
Temperature Humidity Bias	Under Bias at 85°C/85%RH for 1,000 hours JESD22-A101
Thermal Cycling Test	Thermal Cycle from -40°C~125°C, 100 cycles JESD22-A104
Reflow	5 reflow cycles with peak 260°C J-STD-020
Vibration	4 cycles lasting 12 minutes from 20 to 2KHz in X, Y and Z with peak acceleration of 20G JESD22-B103
Mechanical Shock	Total 18 pulses 10,000G in X,Y and Z JESD22-B104
ESD	HBM:3KV, MM:300V, CDM:500V Air Discharge:15KV, Contact Discharg:8KV JESD22-A114(HBM) JESD22-A115(MM) JESD22-C101(CDM) IEC 61000-4-2(Air Discharge) IEC 61000-4-2(Contact Discharge)

Notes: Microphones meet all acoustic and electrical specifications before and after reliability testing, except sensitivity which can deviate up to 3dB from its initial value.

After 5 reflow cycles, the sensitivity of the microphone shall not deviate more than 1 dB from its initial value.

Reflow Profile

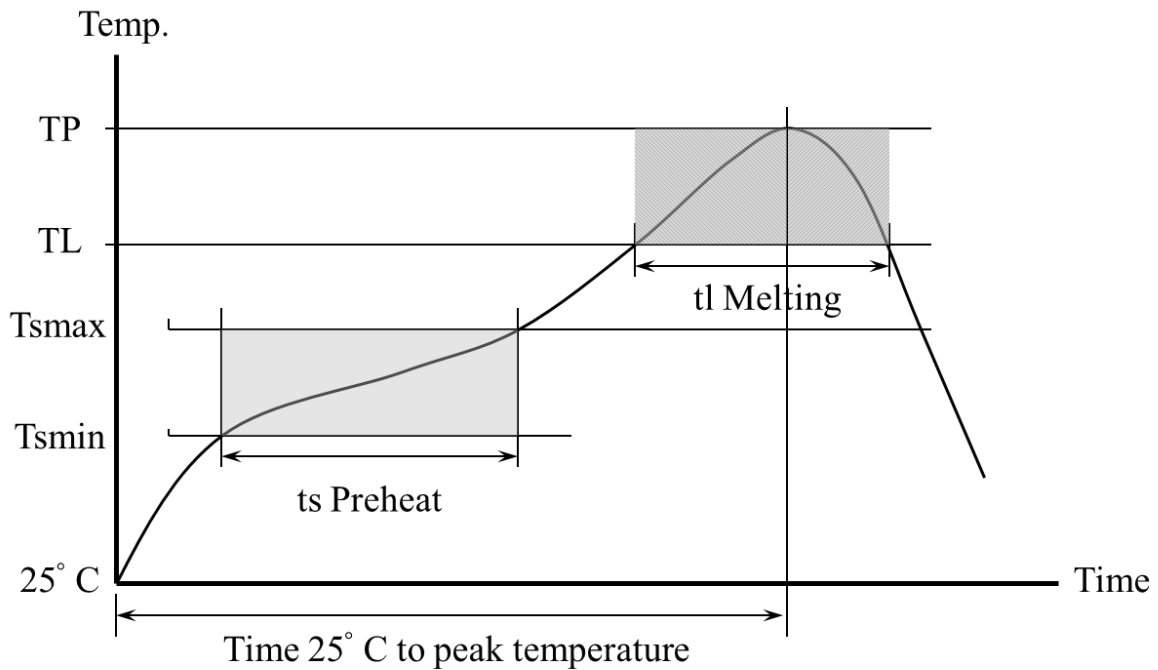

Table 9. Recommended Reflow Profile Limits

Profile Feature	Pb-free
Preheat	
Minimum temperature (Tsmmin)	150 °C
Maximum temperature (Tsmmax)	200 °C
Time (ts)	60~180 sec
Average Ramp up rate (Tsmmax to Tp)	3 °C/sec
Melting area	
Melting temperature (TL)	217 °C
Time maintained above melting (tl)	60~150 sec
Peak Temperature (TP)	260 °C
Time within 5°C of actual peak temperature	20~40 sec
Ramp down rate	6 °C/sec maximum
Time 25°C to peak temperature	8 minute maximum

Notes: Based on IPC/JDEC J-STD-020 Revision F.

All temperatures refer to topside of the package, measured on the package body surface

PCB Land Pattern Layout

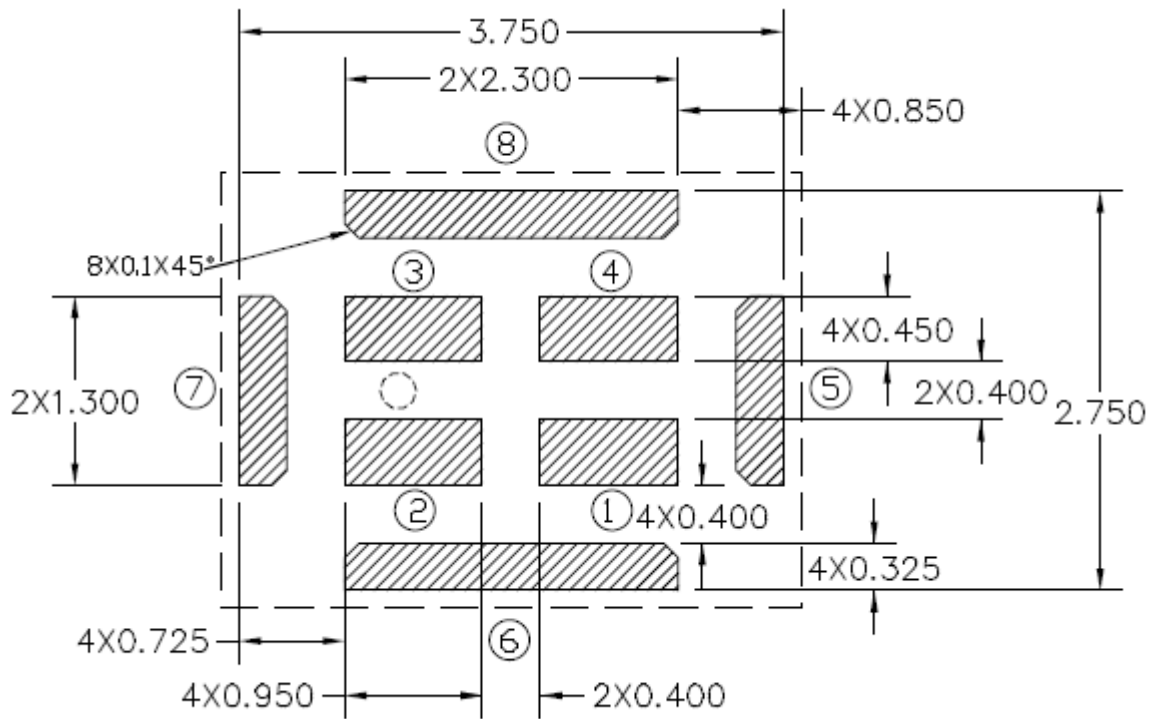

Application Circuit

The L/R pad lets the user to select the DATA signal pattern as explained in Table 7. The L/R pin must be connected to either VDD or GND.

Table 10. L/R channel selection

L/R	CLK low	CLK high
GND	DATA valid	High impedance
VDD	High impedance	DATA valid

Single microphone application:

0.1 μ F ceramic, and 10 μ F ceramic power supply decoupling capacitors should be placed as near as possible to VDD of the device. **The L/R pin must be connected to VDD or GND**

Two microphones application:

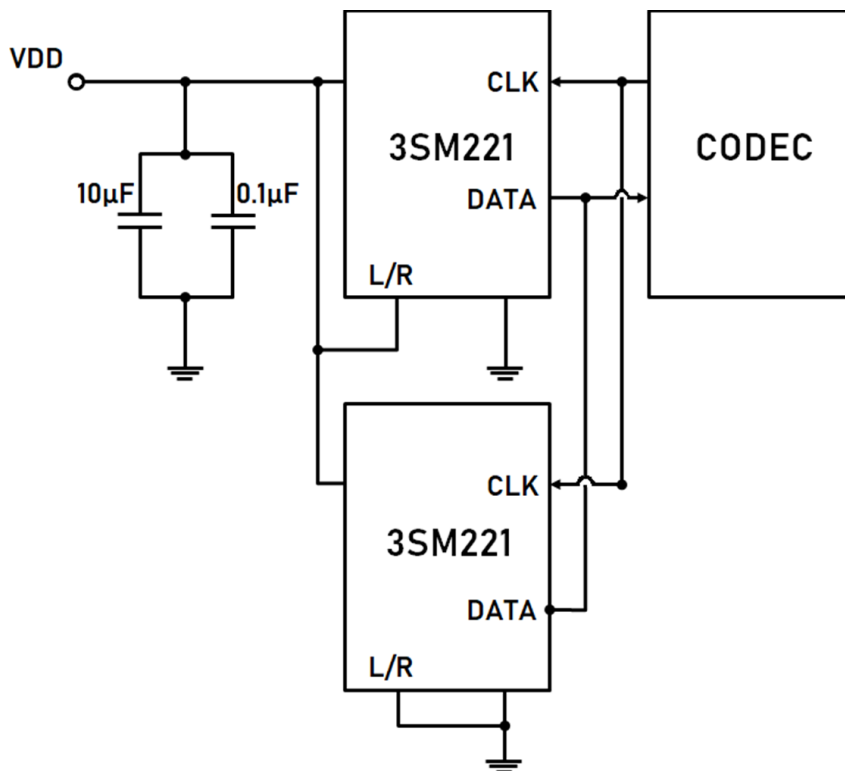

Handling Instructions

The MEMS microphone IC can be handled using standard pick-and-place and chip shooting equipment. Care should be taken to avoid damage to the MEMS microphone IC structure as follows:

- Do not apply vacuum nozzle over the acoustic port (AP) of the microphone to avoid damage to the device.
- Do not blow air directly into acoustic port.
- Brushing the board with/without solvents may damage the device.
- Do not use excessive force to place the microphone on the PCB.
- In case of manual handling, it should be handled with plastic tweezers to avoid damage the device.

Dimensions

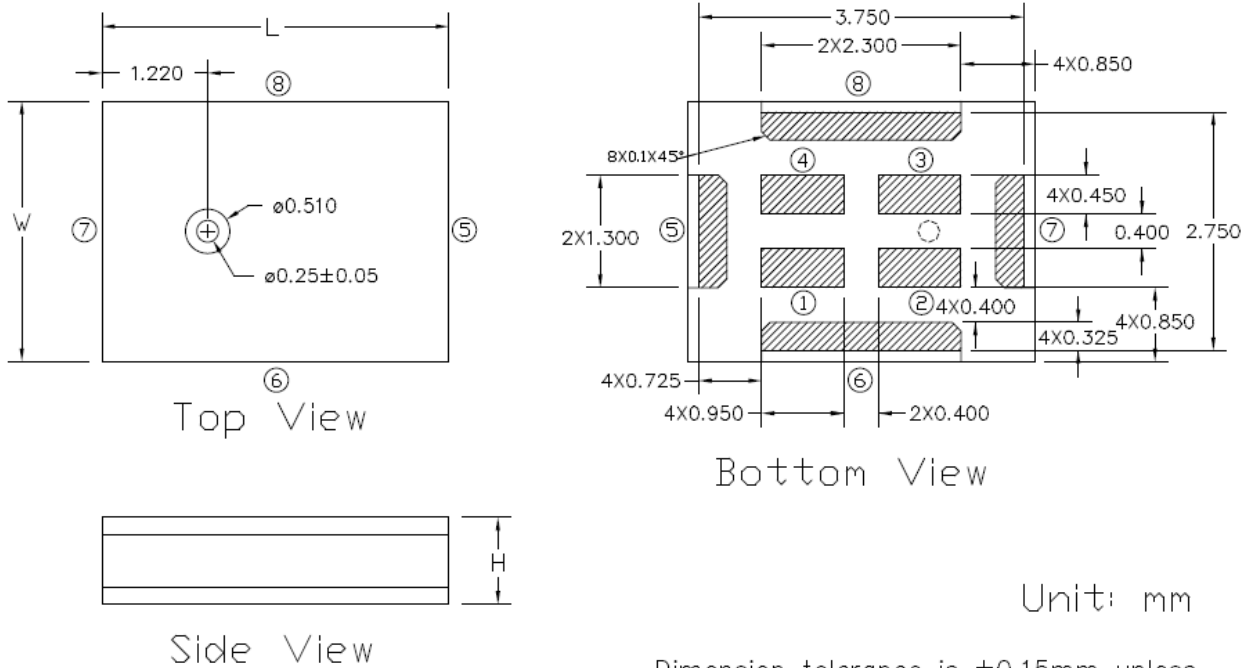

Dimension tolerance is $\pm 0.15\text{mm}$ unless otherwise specified

Table 11. (Top View)

Item	Dimension	Tolerance
Length (L)	4.00mm	$\pm 0.10\text{mm}$
Width (W)	3.00mm	$\pm 0.10\text{mm}$
Height (H)	1.00mm	$\pm 0.10\text{mm}$
Acoustic Port	$\Phi 0.25\text{mm}$	$\pm 0.05\text{mm}$

Package Information

Carrier Tape:

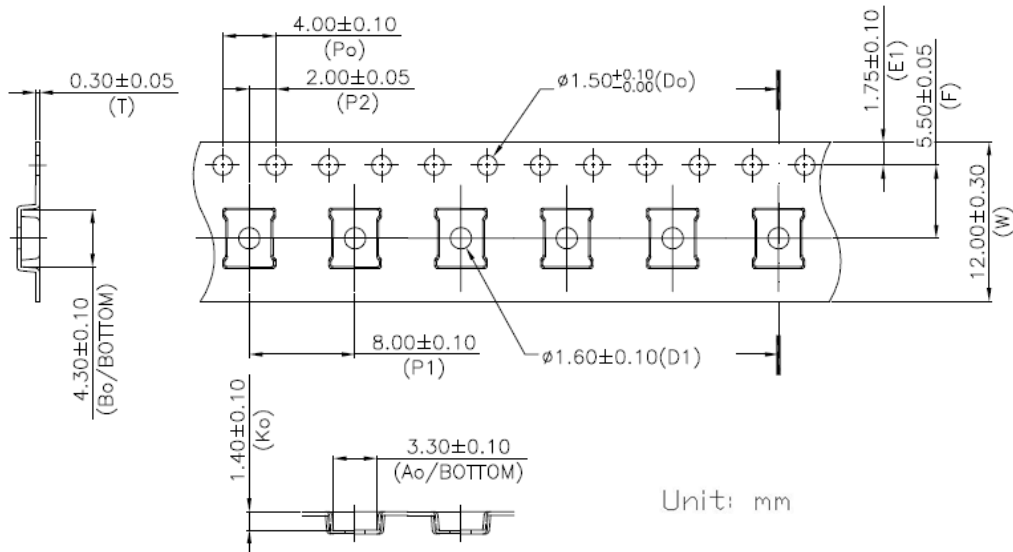

1. 10 sprocket hole pitch cumulative tolerance ± 0.20 .
2. Carrier camber is within 1 mm in 250 mm.
3. Material : Black Conductive Polystyrene Alloy.
4. All dimensions meet EIA-481 requirements.
5. Thickness : 0.30 ± 0.05 mm.
6. MSL(Moisture sensitivity level) 1.
7. Materials comply with ANSI/ESD S20.20 and IEC61340-5-1 standard.

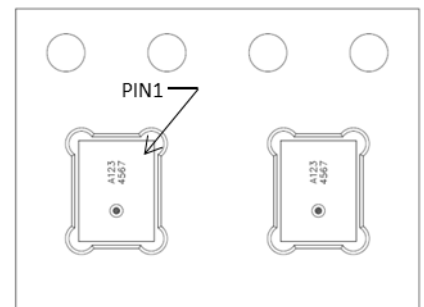

Laser Marking:

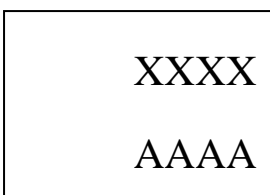

Laser marking on the top side

XXXX	Internal Tracking Code
AAAA	Lot Tracking Code

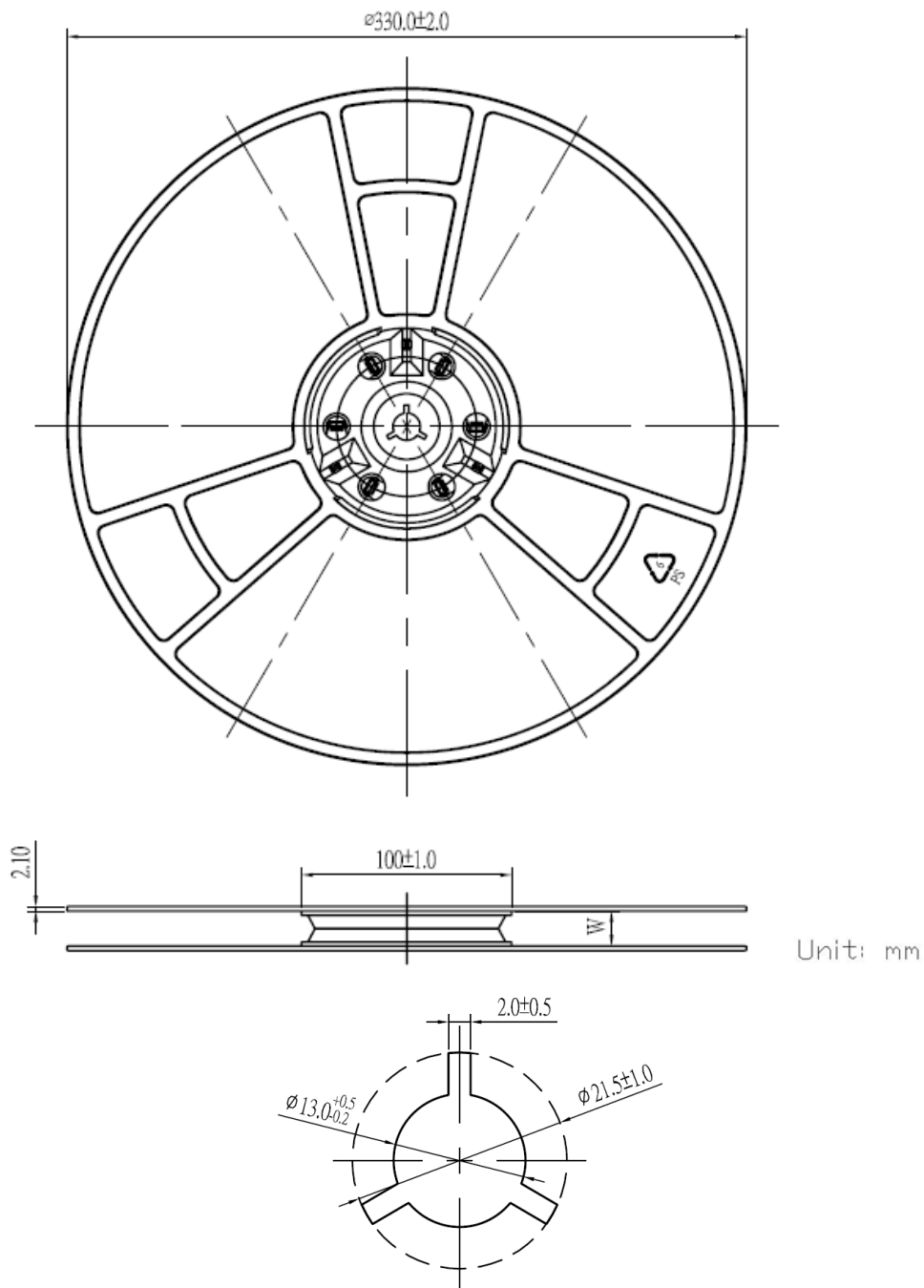
13" Tape Reel :

Model Number	Reel Diameter	Quantity Per Reel
3SM221NMT1KA	13"	5,000

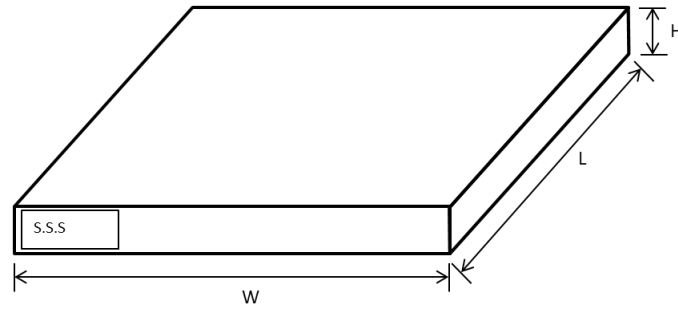
Dimensions for Inner Box :

Unit : mm

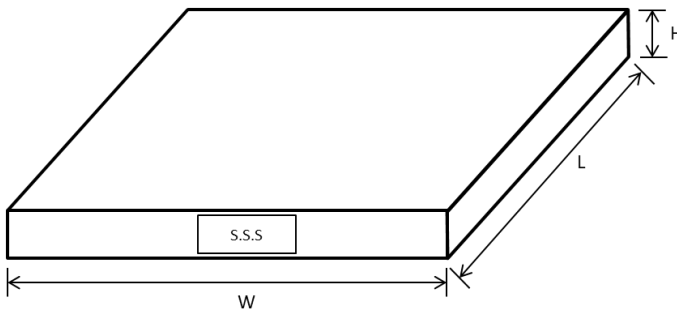
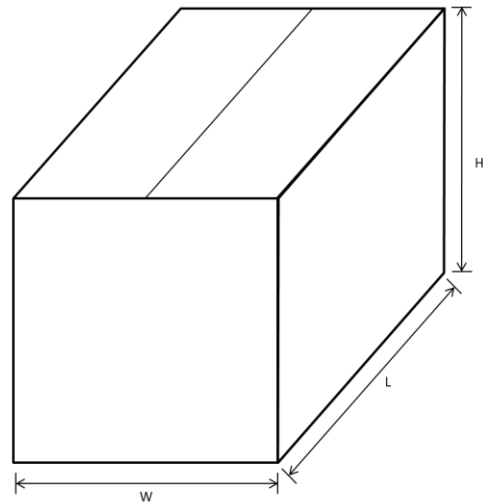
L	W	H
355	375	40

Dimensions for Outer Box:
Outer Box for Quantity 5K-10K

Outer Box for Quantity 15K-30K, 35K-50K

Unit : mm

Quantity	L	W	H
5K - 10K	400	410	100
15K - 30K	380	280	380
35K - 50K	420	380	380

Revision History

Revision	Date	Description
1.0	2025/03/06	Formal release
1.1	2025/03/28	Modify “Acoustical and Electrical Characteristics”