

1. Features and Benefits

- IMC-Hall® Technology
- Very High Field and Extra High Field variants
- End-of-line programmable sensor
- Flexible Supply Voltage with factory selectable 5V or 3.3V mode
- Selectable analog output: Ratiometric or fixed (Vref)
- Measurement range from ± 8 to ± 333 mT
- Wideband sensing: DC to 400kHz
- Very short response time (2 μ s)
- High linearity down to $\pm 0.5\%$ full scale
- AEC-Q100 – Grade 0 Automotive Qualified
- Very low thermal drift for wide temperature range
 - Offset drift (<5mV)
 - Sensitivity drift (<1.5%)
- Dual overcurrent detection
 - Internal threshold
 - External threshold
- RoHS compliant
- SOIC-8 package
- MSL-3



2. Application Examples

- Redundant monitoring of battery-management system (BMS)
- High Voltage Traction Motor Inverter: Phase and DC link current measurement
- 48V Boost Recuperation Inverter
 - Phase current measurement
 - DC link current measurement
- DCDC Converter
- Smart Battery Junction Boxes
- Smart Fuse Overcurrent Detection

3. Description

The MLX91218 is a monolithic Hall-effect sensor utilizing the IMC-Hall® technology. The sensor provides an analog output voltage proportional to the applied magnetic flux density parallel to the IC surface.

The transfer characteristic of the MLX91218 is factory trimmed over temperature, and is programmable (offset, sensitivity, filtering, internal overcurrent threshold) during end-of-line customer calibration. With the 400kHz bandwidth and fast response time, it is particularly adapted for high speed applications such as inverters and converters where fast response time due to fast switching is required.

In a typical current sensing application, the sensor is used in combination with a U-shaped shield which facilitates the mechanical assembly of the current sensor over traditional ferromagnetic cores. This shield is recommended to be laminated for high bandwidth applications. The MLX91218 can then be mounted over the bus bar and separated from it by the PCB. As the shield does not serve the primary purpose of concentration, it can be made smaller and lighter than ferromagnetic cores without losing signal thanks to the integrated magnetic concentrator (IMC) depicted also in Figure 1. As a result, dense power electronics can be achieved enabling system savings and surface mount assembly.

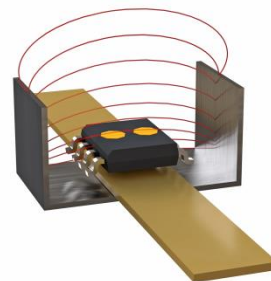

Figure 1: Typical IMC-Hall® Current Sensing Application

Contents

1. Features and Benefits	1
2. Application Examples.....	1
3. Description	1
4. Ordering Information.....	4
5. Functional Diagram.....	6
5.1. Ratiometric Mode.....	6
5.2. Differential or Fixed Mode	7
6. Glossary of Terms	8
7. Pin Definitions and Descriptions	9
8. Absolute Maximum Ratings	10
9. General Electrical Specifications	11
10. Magnetic specification.....	12
10.1. Very High Field version (option code AxV with x = R or F)	12
10.2. Extra High Field version (option code AxX with x = R or F)	13
11. Analog output specification	14
11.1. Definitions	14
11.2. Accuracy specifications	16
11.3. Timing specifications	17
12. Diagnostics	18
13. Overcurrent Detection Specification.....	18
13.1. General.....	18
13.2. Electrical Specifications.....	19
13.3. Timing Specifications.....	19
13.4. Internal Overcurrent Detection Principle.....	20
13.5. External Overcurrent Detection Principle	20
14. Recommended Application Diagram	22
14.1. Resistance on reference voltage pin	23
15. Standard Information	25
16. ESD Precautions.....	26
17. Packaging information.....	26
17.1. SOIC-8 Pinout and Marking.....	27

17.2.	Hall plate position.....	27
17.3.	IMC Position and sensor active measurement direction	28
18.	Contact.....	29
19.	Disclaimer.....	30

4. Ordering Information

Product	Temperature	Package	Option Code	Packing Form	Typical Sensitivity	Supply Voltage	Reference Voltage	OCD Level
MLX91218	L	DC	ARV-500	RE	40 mV/mT	5V	NA	134.7 %FS
MLX91218	L	DC	ARV-501	RE	60 mV/mT	5V	NA	134.7 %FS
MLX91218	L	DC	ARV-300	RE	25 mV/mT	3.3V	NA	124.9 %FS
MLX91218	L	DC	ARV-301	RE	35 mV/mT	3.3V	NA	124.9 %FS
MLX91218	L	DC	ARV-303	RE	30 mV/mT	3.3V	NA	124.9 %FS
MLX91218	L	DC	AFV-204	RE	80 mV/mT	3.3V	0.5 V	172.6 %FS
MLX91218	L	DC	ARX-501	RE	30 mV/mT	5V	NA	134.7 %FS
MLX91218	L	DC	ARX-502	RE	25 mV/mT	5V	NA	134.7 %FS
MLX91218	L	DC	ARX-503	RE	37 mV/mT	5V	NA	110.0 %FS
MLX91218	L	DC	ARX-300	RE	14 mV/mT	3.3V	NA	124.9 %FS
MLX91218	L	DC	ARX-301	RE	19 mV/mT	3.3V	NA	124.9 %FS

Table 1: Available ordering codes.

Legend:

Temperature Code	L	from -40°C to 150°C ambient temperature
Package Code	DC	for SOIC8 package, refer to Chapter 17 for detailed drawings
Option Code	Axx-xxx	“A” for silicon version
	xRx-xxx	“R” for ratiometric output mode
	xFx-xxx	“F” for fixed output mode
	xxV-xxx	“V” for Very High Field IMC
	xxX-xxx	“X” for Extra High Field IMC
	xxx-2xx xxx-3xx xxx-4xx xxx-5xx	“2” for 3.3V supply, unipolar output “3” for 3.3V supply, bipolar output “4” for 5V supply, unipolar output “5” for 5V supply, bipolar output
xxx-500 xxx-303 ..	“500” for a sensitivity of 40mV/mT and overcurrent detection of 134.7% full scale “303” for a sensitivity of 30mV/mT and overcurrent detection of 124.9% full scale ..	
Packing Form	RE SP TU	Plastic Tape on Reel. Sample pack Tube
Ordering Example	“MLX91218LDC-ARV-501-RE” MLX91218 IMC-Hall® current sensor in SOIC8 package, temperature range -40°C to 150°C. Analog ratiometric output, Very high Field IMC, Sensitivity 30mV/mT. Parts delivered in Plastic Reel	

Table 2: Legend ordering codes

Melexis is continuously expanding its product portfolio by adding new option codes to better meet the needs of our customer’s applications. This table is being updated frequently, please go to the Melexis website to download the latest version of this datasheet. For custom transfer characteristics, please contact your local Melexis Sales representative or distributor.

5. Functional Diagram

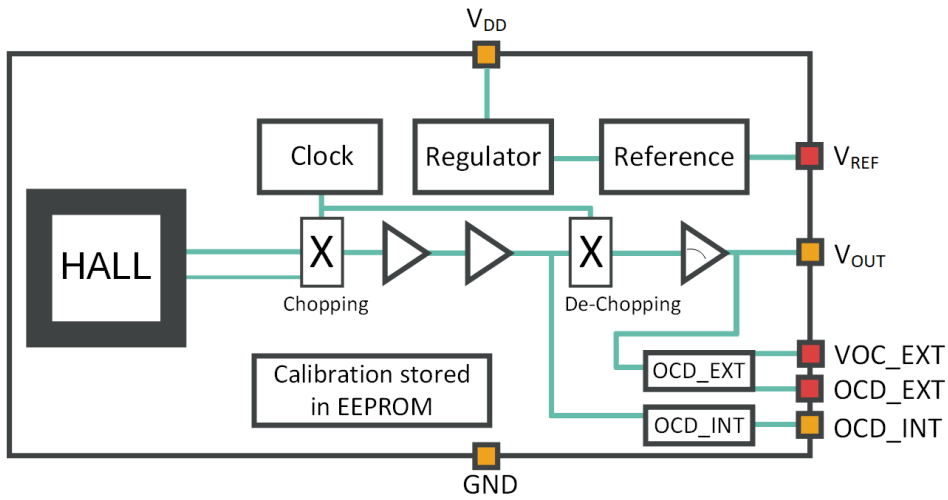

Figure 2: Block Diagram of the MLX91218

5.1. Ratiometric Mode

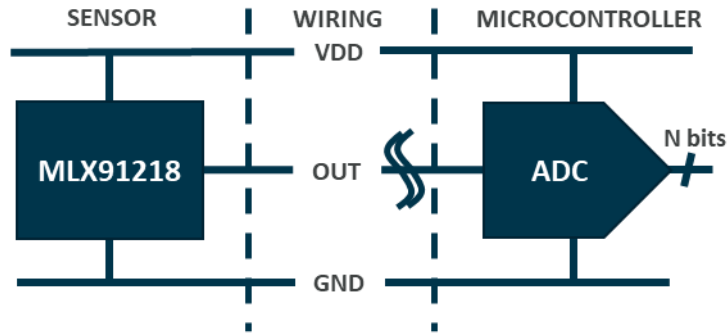

Figure 3: Schematic of ratiometric mode

No matter if the V_{DD} line is at 5V or deviating +/-10%, the ADC code for a given measured magnetic field will always be the same as the ADC is supplied by the same voltage as the sensor.

5.2. Differential or Fixed Mode

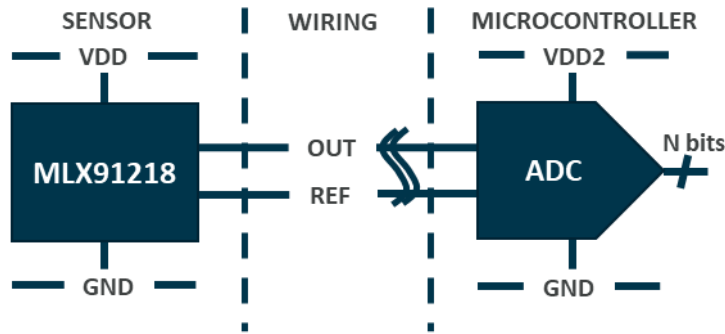

Figure 4: Schematic of fixed mode

In this particular case the ADC does not necessarily share the same supply voltage with the sensor. For this reason, the sensor is calibrated with an absolute sensitivity regardless of the actual supply voltage. The output signal can be reconstructed by taking the difference between the output and the reference voltage from the IC. The ADC gets these two signals as inputs for establishing the sensed magnetic field accurately, and is not influenced by the supply voltage differences between both sensor and microcontroller, if applicable. Only available in SOIC8 package.

Parameter	Ratiometric Mode	Differential or Fixed Mode
Output Signal	$V_{OUT} [\%V_{DD}]$ Example: output is 2.5V when supply is 5V → output is then 50% V_{DD} . If the supply (V_{DD}) increases with 5% to 5.25V the sensor output will (for the same measured input magnetic field) scale proportionally with the supply voltage, becoming 2.625V, but as a percentage (i.e. ratiometrically seen) it remains at 50% of V_{DD} .	$V_{OUT} - V_{REF} [V]$ Example: V_{OUT} and V_{REF} output is 2.501V and V_{REF} is 2.501V when supply is 5V. When the supply voltage is increasing to 5.1V due to supply system variation, the sensor will still maintain the same “fixed” output values V_{OUT} and V_{REF} equal to 2.501V.
Offset (V_{OUT} at magnetic field 0mT)	50 [% V_{DD}] (factory trimmed)	V_{REF} (factory trimmed)
Offset ratiometric	Yes	No
Sensitivity	$[\%V_{DD}/mT]^1$	[mV/mT]
Sensitivity ratiometric	Yes	No
Measured magnetic field B	$B = \frac{(V_{OUT} - V_{OUT}[0mT])}{Sensitivity}$	$B = \frac{(V_{OUT} - V_{REF})}{Sensitivity}$

Table 3: Parameters of differential and fixed modes

¹ The sensitivity in ratiometric mode is expressed as [%VDD/mT]. However, for simplicity, in the datasheet the sensitivity will be always expressed in [mV/mT]. For ratiometric devices, this corresponds to the sensitivity for VDD=5V or 3.3V, depending on the settings of the sensor.

6. Glossary of Terms

Terms	Definition
TC	Temperature Coefficient
FS	Full Scale, output referred. Corresponds to 2V excursion around 2.5V at 5V supply or 1.25V excursion from 1.65V at 3.3V supply for bipolar designs
T, mT	Tesla, milliTesla = units for the magnetic flux density
G	Gauss = unit for the magnetic flux density [1mT = 10G]
PTC	Programming Through Connector
IMC	Integrated Magnetic Concentrator
OCD	Overcurrent detection
MSL	Moisture Sensitivity Level
RoHS	Restriction of Hazardous Substances Directive

Table 4: Glossary of Terms

7. Pin Definitions and Descriptions

Note: MLX91218 is not pin-to-pin compatible with MLX91208 or MLX91216.

Pin #	Name	Type	Description
1	VREF	Analog	Reference voltage
2	OUT	Analog Output	Output voltage (measurement)
3	GND	Supply	Ground voltage
4	VDD	Supply	Supply voltage
5	NC	-	Not connected
6	OCD_EXT	Analog Output	Overcurrent detection based on external threshold
7	OCD_INT	Analog Output	Overcurrent detection based on internal threshold
8	VOC_EXT	Analog Input	External threshold for the OCD

Table 5: Pin definitions and descriptions

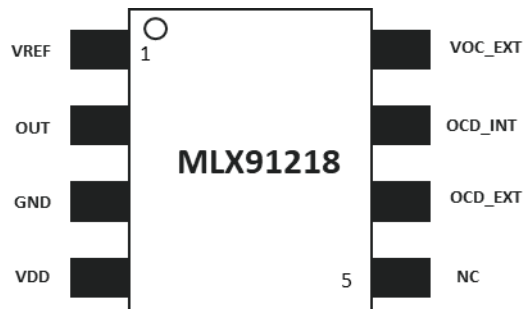

Figure 5: Pinout MLX91218

For optimal EMC results, it is recommended to connect the unused (NC) pins to the Ground.

8. Absolute Maximum Ratings

Exceeding the absolute maximum ratings may cause permanent damage. Exposure to absolute maximum-rated conditions for extended periods of time may affect device reliability.

Parameter	Symbol	Value	Unit
Positive Supply Voltage (overvoltage)	V_{DD}	+8	V
Negative Supply Voltage	V_{DD}	-0.3	V
Positive Pin Voltage ²	V_{PIN}	$V_{DD} + 0.3$	V
Output Sink Current	I_{out_max}	50	mA
Output Source Current	I_{out_source}	25	mA
Output Short Circuit Current to GND	I_{SHORT_GND}	-100	mA
Output Short Circuit Current to V_{DD}	I_{SHORT_VDD}	60	mA
Reverse Pin Voltage ²	V_{min_REV}	GND-0.3	V
Maximum Junction Temperature	T_{j_MAX}	165	°C
Operating Ambient Temperature Range	T_A	-40 to +150	°C
Storage Temperature Range	T_S	-55 to +165	°C
Magnetic Flux Density	B_{MAX}	±3	T
Human Body ESD Protection	ESD_{HBM}	2	kV
Charged Device Model ESD Protection	ESD_{CDM} All pins	500	V
	ESD_{CDM} Corner pins	750	V

Table 6: Absolute maximum ratings

² Except for V_{DD} and GND

9. General Electrical Specifications

Operating Parameters $T_A = -40$ to 150°C and $V_{DD}=5$ V or 3.3 V.

Parameter	Symbol	Test Conditions	Min	Typ	Max	Units
Nominal Supply Voltage	V_{DD}	MLX91218LDC-Axx-5xx MLX91218LDC-Axx-3xx	4.5 3.135	5 3.3	5.5 3.465	V
Positive Supply Voltage (maintaining application mode)	V_{DD}				6.5	V
Supply Current	I_{DD}	Without R_{LOAD} on output, in application mode VDD= 5V VDD=3.3		15.5 15	19 18	mA
Output Resistance	R_{OUT}	$V_{OUT} = 50\%V_{DD}$, $I_{LOAD} = 10\text{mA}$		1	5	Ω
Voltage Reference Output Resistance	R_{REF}	VREF=2.5V : ISINK =5mA VREF=1.65V or VREF=1.5V : ISINK =3mA VREF=0.5V : ISINK =1mA ISOURCE = 0.2mA	120	200	333	Ω
Output Capacitive Load	C_{LOAD}	Output amplifier stability is optimized for this typical value	0	4.7	6	nF
Output Leakage current	I_{LEAK}	High impedance mode, $T_A=150^\circ\text{C}$		6	20	μA
Output Voltage Linear Swing	V_{OUT_LSW}	Pull-down or pull-up ≥ 10 k Ω VDD > 4.6 V for Fixed Mode versions	10		90	$\%V_{DD}$

Table 7: General electrical parameters

10. Magnetic specification

Operating Parameters $T_A = -40$ to 150°C , $V_{DD}=5$ V or 3.3 V factory trimmed devices unless otherwise specified.

10.1. Very High Field version (option code AxV with x = R or F)

Parameter	Symbol	Test Conditions	Min	Typ	Max	Units
Operational Magnetic Field Range	B_{OP}				± 60	mT
Linearity Error (Magnetic)	NL	B within B_{OP} , $T_A = 25^\circ\text{C}$			± 0.5	%FS
Hysteresis – Remanent Field	B_R	Measured after $B = B_{OP}$			± 60	μT
Programmable Sensitivity	S_{PROG}	Generic part, 5V	30		165	mV/mT
		Generic part, 3.3V	18		125	
		MLX91218LDC-ARV-500	33.5	40	71	
		MLX91218LDC-ARV-501	33.5	60	71	
		MLX91218LDC-ARV-300	22	25	35	
		MLX91218LDC-ARV-301	22	35	35	
		MLX91218LDC-ARV-303	22	30	35	
MLX91218LDC-AFV-204	47.5	80	165			
Sensitivity accuracy (factory trimming)	S_{ACC}		-1		+1	%S
Sensitivity Programming Resolution	S_{RES}	$B = B_{OP}$		0.5		%S

Table 8: Magnetic specification Very High Field version

10.2. Extra High Field version (option code AxX with x = R or F)

Parameter	Symbol	Test Conditions	Min	Typ	Max	Units
Operational Magnetic Field Range	B _{OP}				±90	mT
Linearity Error (Magnetic)	NL	B within B _{OP} , T _A = 25°C			±0.5	%FS
Hysteresis – Remanent Field	B _R	Measured after B = B _{OP}			±90	μT
Programmable Sensitivity	S _{PROG}	Generic part, 5V	16		115	mV/mT
		Generic part, 3.3V	12		80	
		MLX91218LDC-ARX-501	20	30	40	
		MLX91218LDC-ARX-502	20	25	40	
		MLX91218LDC-ARX-503	20	37	40	
		MLX91218LDC-ARX-300	13.2	14	19.5	
MLX91218LDC-ARX-301	13.2	19	19.5			
Sensitivity accuracy (factory trimming)	S _{ACC}	T _A = 25°C	-1		+1	%S
Sensitivity Programming Resolution	S _{RES}	B = B _{OP}		0.5		%S

Table 9: Magnetic specification Extra High Field version

11. Analog output specification

11.1. Definitions

11.1.1. Thermal Reference Drift

The thermal reference drift is the variation of the reference voltage (V_{REF}) over temperature. It is expressed in ppm/°C.

$$+ \Delta T_{VREF} = \left(\frac{V_{ref}[125^{\circ}\text{C}]}{V_{ref}[25^{\circ}\text{C}]} - 1 \right) \cdot \frac{1}{(125 - 25)} \cdot 10^6$$

$$- \Delta T_{VREF} = \left(\frac{V_{ref}[-40^{\circ}\text{C}]}{V_{ref}[25^{\circ}\text{C}]} - 1 \right) \cdot \frac{1}{(-40 - 25)} \cdot 10^6$$

11.1.2. Voltage Output Quiescent

V_{OQ} corresponds to the difference between the measured and the ideal outputs when no magnetic field is applied to the MLX91219 at $T_A=25^{\circ}\text{C}$.

$$V_{OQ} = V_{OUT}[0mT]_{measured} - V_{OUT}[0mT]_{ideal}$$

11.1.3. Thermal Offset Drift

$\Delta T_{V_{OQ}}$ corresponds to variation of V_{OQ} in temperature.

11.1.4. Sensitivity

The sensitivity is the ratio between the output of the MLX91218 and the input current.

For ratiometric devices, as the output will scale with the supply, sensitivity is expressed as $[\%V_{DD}]/mT$. For simplicity, in the datasheet the sensitivity will be always expressed in mV/mT. For ratiometric devices, this corresponds to the sensitivity for $V_{DD}=5V$ or $3.3V$, depending on the settings of the sensor.

For fixed devices, the output does not vary with the V_{DD} , sensitivity is thus expressed as mV/A.

11.1.5. Linearity Error

The linearity error is the deviation of the output from the expected linear behaviour. To obtain the linearity error, the current is swept from $-I_{PM}$ to I_{PM} . To decorrelate the thermal drift from the linearity error, the junction temperature should be fixed below 50°C .

$$NL = \frac{V_{out}[I] - BESTFIT(V_{out}[I])}{V_{out}[I_{PM}] - V_{out}[-I_{PM}]} \cdot 100 \quad [\%FS]$$

11.1.6. Ratiometry Offset and Sensitivity Error

Ratiometric Mode

In Ratiometric mode, V_{OUT} and V_{REF} are scaled with the supply voltage. $V_{DDnom} = 5V$

Ratiometric V_{OQ} Error:

$$\Delta R_{VOQ} = V_{OQ} [V_{DDnom}] - V_{OQ} [V_{DDnom} \pm 10\%] \frac{V_{DDnom}}{V_{DDnom} \pm 10\%} [mV]$$

Ratiometric Sensitivity Error:

$$\Delta R_S = 100 \cdot \left(1 - \frac{S[V_{DDnom} \pm 10\%]}{S[V_{DDnom}]} \cdot \frac{V_{DDnom}}{V_{DDnom} \pm 10\%} \right) [\%]$$

In the datasheet, the ratiometric error is expressed as $\frac{mV}{\%VDD}$ for the offset, and $\frac{\%S}{\%VDD}$ for the sensitivity. For instance, if the supply voltage changes by 3%, the typical error on the sensitivity will be $0.16 \frac{\%S}{\%VDD} \times 3\% = 0.48\%$.

Fixed Mode

In Fixed mode, V_{OUT} and V_{REF} are not scaled with the supply voltage. Ideally, they do not vary. $V_{DDnom} = 5V$

Non-Ratiometric V_{OQ} Error:

$$\Delta R_{VOQ} = V_{OQ} [V_{DDnom} \pm 10\%] - V_{OQ} [V_{DDnom}] [mV]$$

Non-Ratiometric Sensitivity Error:

$$\Delta R_S = \left(\frac{S[V_{DDnom} \pm 10\%]}{S[V_{DDnom}]} - 1 \right) \cdot 100 [\%]$$

11.2. Accuracy specifications

Operating Parameters $T_A = -40$ to 150°C , $V_{DD}=5$ V or 3.3 V factory trimmed unless otherwise specified.

Parameter	Symbol	Test Conditions	Min	Typ	Max	Units
Voltage Reference	V_{REF}	$T_A=25^\circ\text{C}$, AFx-5xx versions, RS=0 $T_A=25^\circ\text{C}$, AFx-3xx versions, RS=1 $T_A=25^\circ\text{C}$, AFx-3xx versions, RS=2 $T_A=25^\circ\text{C}$, AFx-2xx/AFx-4xx, RS=3	2.48 1.64 1.492 0.495	2.5 1.65 1.5 0.5	2.52 1.66 1.508 0.505	V
Non-ratiometric VREF Error	ΔV_{REF}	Fixed mode devices	-3		3	mV
Thermal Reference Drift	ΔT_{VREF}	Variation versus 25°C , $V_{REF}=2.5\text{V}$, 1.65V, 1.5V Variation versus 25°C , $V_{REF}=0.5\text{V}$			± 150 ± 300	ppm/ $^\circ\text{C}$
Voltage Output Quiescent	V_{OQ}	No magnetic field applied, $T_A=25^\circ\text{C}$	-5		5	mV
Ratiometric Offset Error ³	$\Delta^R V_{OQ}$	$V_{DD} = 5\text{V}$ $V_{DD} = 3.3\text{V}$		1.6 1		mV/ $\%V_{DD}$
Non-Ratiometric Offset Error	$\Delta^R V_{OQ}$	$V_{DD} = 5\text{V}$ $V_{DD} = 3.3\text{V}$		5 5		mV
Thermal Offset Drift ⁴	$\Delta^T V_{OQ}$	$T_A = -40$ to 125°C $T_A = -40$ to 150°C ⁵	-5	± 6	5	mV
Total Offset Drift ⁶	ΔV_{OQ}	$T_A = -40$ to 125°C $T_A = -40$ to 150°C		± 6 ± 8		mV
Ratiometric Sensitivity Error ³	$\Delta^R S$			0.16		$\%S/\%V_{DD}$
Non-Ratiometric Sensitivity Error	$\Delta^R S$		-0.6		0.6	$\%S$
Thermal Sensitivity Drift ⁴	$\Delta^T S$	$T_A = -40$ to 125°C $T_A = -40$ to 150°C ⁵	-1.5	± 1 ± 2.2	1.5	$\%S$
Total Sensitivity Drift ⁶	ΔS	$T_A = -40$ to 125°C $T_A = -40$ to 150°C		± 1.5 ± 2.5		$\%S$
Input referred noise spectral density	N_{PSD}	within BW = 1 .. 400kHz, Max gain option code AxV option code AxX		110 175		nT/ $\sqrt{\text{Hz}}$

Table 10: Accuracy specifications – analog parameters

³ Ratiometry Error is verified at maximum V_{DD} deviation ($5\%V_{DD}$ at 3.3V and $10\%V_{DD}$ at 5V) over temperature in production. Typical values are the maximum mean ± 3 sigma out of all characterized lots.

⁴ Performance after factory trimming

⁵ Based on results from AEC-Q003 Characterization. Typical values are the maximum mean ± 3 sigma out of all characterized lots.

⁶ After 1000h HTOL at $T_A = 155^\circ\text{C}$ with respect to after pre-conditioning at $T_A = 35^\circ\text{C}$. Pre-conditioning is performed with MSL level 3 based on J-STD-020. Typical values are the highest average ± 3 sigma across all qualification lots.

The accuracy specifications are defined for the factory calibrated sensitivity. The achievable accuracy is dependent on the user’s end-of-line calibration. Resolution for offset and offset drift calibration is better than 0.05%V_{DD}. Trimming capability is higher than measurement accuracy. End-user calibration can therefore increase the accuracy of the system.

11.3. Timing specifications

Operating Parameters T_A = -40 to 150°C, V_{DD}=5 V or 3.3 V factory trimmed unless otherwise specified.

Parameter	Symbol	Test Conditions	Min	Typ	Max	Units
Step Response Time	T _{RESP}	Delay between the input signal reaching 90% and the output reaching 90% (see Error! Reference source not found.) SF=1 (default) SF=2 SF=3			2 3.5 6	μs
Bandwidth	BW	-3dB, T _A =25°C SF=1 (default) SF=2 SF=3		400 200 100		kHz
Power on Delay ⁷	T _{POD}	VREF capacitor = 47nF			1	ms

Table 11: Timing specifications of the high-speed analog output

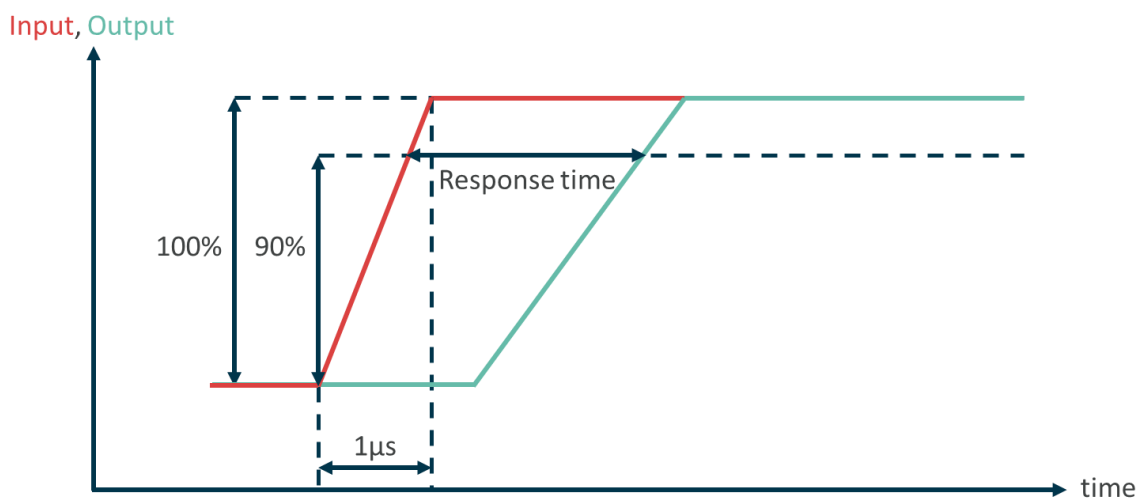

Figure 6: Response Time definition

⁷During the power on, the output follows a routine and is not valid (i.e. it is not related to magnetic field) for T_{POD}=1ms.

12. Diagnostics

It is possible to take advantage of diagnostic features, with the help of adding a pull-down resistor (see Section 14). If a failure event occurs, the measured output will be set to ground. This can be interpreted as failure by the microcontroller unit.

Error	Effect on Output
Calibration data CRC Error	Output stage in high-Z mode. A pull-down resistor to ground will result in output equal to ground.
VDD Under voltage	
Thresholds:	Output is pulled to GND with a 2kΩ resistance, until VDD is inside the specified ranges, depending if the device is powering on or off.
<ul style="list-style-type: none"> Power-up: VDD < 2.8V Power-down: VDD < 2.5V 	
Broken OUT	Pull-down external resistor allows to measure a voltage equal to GND.

Table 12: Description of the diagnostic modes in MLX91218

13. Overcurrent Detection Specification

13.1. General

The MLX91218 provides two OCD features that allow detecting overcurrent applied on the integrated sensor primary. In case of OCD detection, the OCD_{INT} or OCD_{EXT} is pulled to ground. During normal operation the OCD voltage remains at V_{DD} . If not used, OCD_{INT} and OCD_{EXT} can be connected to GND.

The two OCD functions are able to react to an overcurrent event within few μs of response time. To avoid false alarm, the overcurrent has to be maintained at least $1\mu s$ for the detection to occur. After detection by the sensor the output flag is maintained for $10\mu s$ of dwell time. This allows the overcurrent to be easily detected at microcontroller level.

The following table offers a comparison between OCD_{INT} and OCD_{EXT} :

Description	OCD_{INT}	OCD_{EXT}
Typical Application	Short-circuit detection	Out-of-range detection
Overcurrent effect	OCD_{INT} pin to GND	OCD_{EXT} pin to GND
Detection mode	Bidirectional	Unidirectional / bidirectional
Threshold trimming	EEPROM	Voltage divider on VOC_{EXT}

Table 13: Comparison between OCD_{INT} and OCD_{EXT}

13.2. Electrical Specifications

Operating Parameters $T_A = -40$ to 150°C , $V_{DD}=5$ V or 3.3 V factory trimmed unless otherwise specified.

Parameter	Symbol	Test Conditions	Min	Typ	Max	Units
OCD_INT Internal ON Resistance	$R_{ON_OCD_INT}$	$I_{SINK} = 1$ mA	60	90	150	Ω
OCD_EXT Internal ON Resistance	$R_{ON_OCD_EXT}$	$I_{SINK} = 1$ mA	160	190	280	Ω
VOC_EXT Voltage Range ⁸ $V_{DD}= 5$ V, 5xx versions	VOC_{EXT_5V}	$R_S = 0$, Bidirectional $R_S = 3$, Unidirectional	0.5 0.9		2.0 4.5	V
VOC_EXT Voltage Range ⁸ $V_{DD}= 3.3$ V, 3xx versions	VOC_{EXT3V3}	$R_S = 1$, Bidirectional $R_S = 3$, Unidirectional	0.5 0.74		1.525 2.9	V
OCD_INT accuracy	OCD_INT	Ratiometric output ⁹		± 10		%Thr ¹⁰
OCD_EXT accuracy	OCD_EXT			± 1.5		%FS

Table 14: Electrical Specifications OCD

13.3. Timing Specifications

Operating Parameters $T_A = -40$ to 150°C , $V_{DD}=5$ V or 3.3 V factory trimmed unless otherwise specified.

Parameter	Test Conditions	Min	Typ	Max	Units
OCD_INT response time	TDT=0 TDT=1		1.4 2.1		μs
OCD_EXT response time			10		μs
OCD_INT required Input holding time			1		μs
OCD_EXT required Input holding time			10		μs
OCD_INT output dwell time		7		14	μs
OCD_EXT output dwell time			10		μs

Table 15: OCD_INT and OCD_EXT timing specifications

⁸ VOC_{ext} defines the OCD_{EXT} threshold. In case of a ratiometric device, VOC_{ext} should change with V_{dd} to avoid additional errors.

⁹ OCD_{INT} threshold will not scale with V_{DD} variation (in ratiometric output mode) therefore at lower supply voltage results in a higher OCD_{INT} threshold and vice versa. V_{DD} variation should be accounted for when defining the OCD threshold.

¹⁰ The error of OCD_{INT} is expressed as percentage of the threshold value. Example: if the nominal threshold is 85.33mT, the typical threshold of OCD_{INT} will be in the range between 76.8mT and 93.86mT

13.4. Internal Overcurrent Detection Principle

The internal OCD takes the threshold voltage values predefined in the EEPROM and does not require any extra components. The OCD_{INT} implementation allows detecting overcurrent outside of the output measurement range of the sensor and is therefore suitable for large current peaks as occurring during short-circuit. If the theoretical sensor output overcomes the OCD_{INT} voltage threshold, the overcurrent event is flagged on OCD_{INT} pin. The default OCD threshold voltages are defined as follows, but other values can be set on request.

Sensor reference	Typical Sensitivity [mV/mT]	OCD_{INT} Threshold Current [%FS]
MLX91218LDC-ARV-500-RE	40	134.7
MLX91218LDC-ARV-501-RE	60	134.7
MLX91218LDC-ARV-300-RE	25	124.9
MLX91218LDC-ARV-301-RE	35	124.9
MLX91218LDC-ARV-303-RE	30	124.9
MLX91218LDC-AFV-204-RE	80	172.6
MLX91218LDC-ARX-501-RE	30	134.7
MLX91218LDC-ARX-502-RE	25	134.7
MLX91218LDC-ARX-503-RE	37	110.0
MLX91218LDC-ARX-300-RE	14	124.9
MLX91218LDC-ARX-301-RE	19	124.9

Table 16: OCD_{INT} thresholds

	Sensor configuration	Min [% FS]	Max [% FS]
OCD_{INT} Threshold	$V_{DD} = 5V / V_{REF} = 2.5V$	25.5	215.8
	$V_{DD} = 5V / V_{REF} = 0.5V$	12.8	107.9
	$V_{DD} = 3.3V / V_{REF} = 1.65V$	40.8	345.3
	$V_{DD} = 3.3V / V_{REF} = 0.5V$	20.4	172.6

Table 17: OCD_{INT} factory programmable range

13.5. External Overcurrent Detection Principle

The external OCD uses the voltage applied on VOC_{EXT} pin as threshold voltage. This translates into an overcurrent threshold depending on the sensitivity of the sensor. A voltage divider on VOC_{EXT} allows defining the threshold voltage in a custom way. Depending on the voltage divider configuration, the OCD_{EXT} can be used either in bidirectional or unidirectional mode. The External OCD threshold is defined within the measurement range of the sensor output. This feature is then suitable for out-of-range detection where the OCD threshold remains close to the nominal current. It offers a better accuracy than OCD_{INT} but the response is slower. The below table

presents the unidirectional and bidirectional external OCD configurations. Please refer to section 13 for more details about the application diagram and the recommended resistances.

Bidirectional configuration	Unidirectional configuration
$VOC_{EXT} = V_{REF} * \frac{R_4}{R_3 + R_4}$ $VLocd = VOC_{EXT}$ $VHocd = 2 * V_{REF} - VLocd$	$VOC_{EXT} = V_{REF} + (V_{DD} - V_{REF}) * \frac{R_3}{R_3 + R_{4bis}}$ $VHocd = VOC_{EXT}$

Table 18: External OCD, bidirectional and unidirectional configurations

14. Recommended Application Diagram

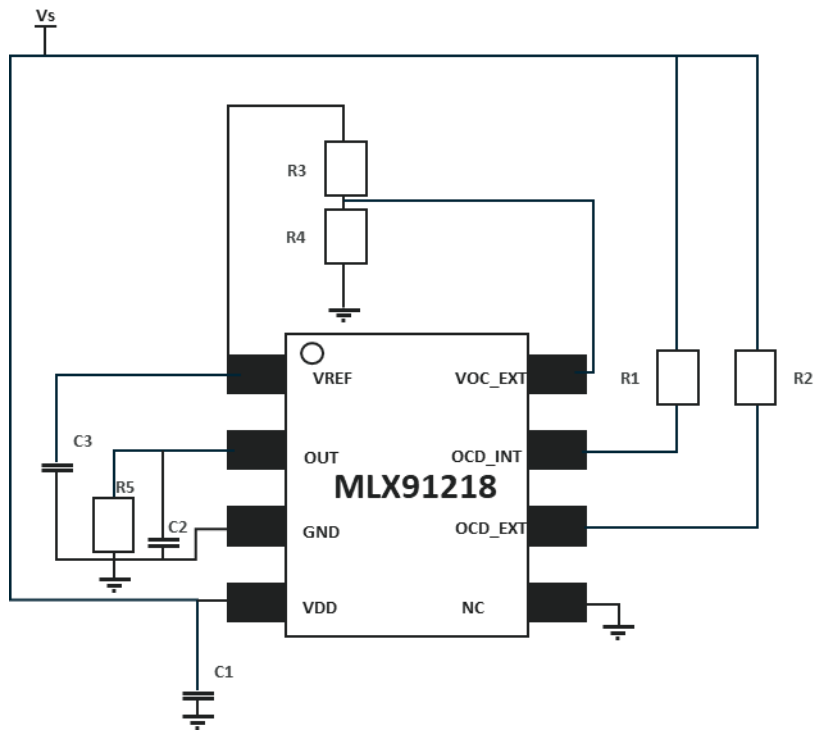

Figure 7: Application Diagram for Bidirectional External OCD

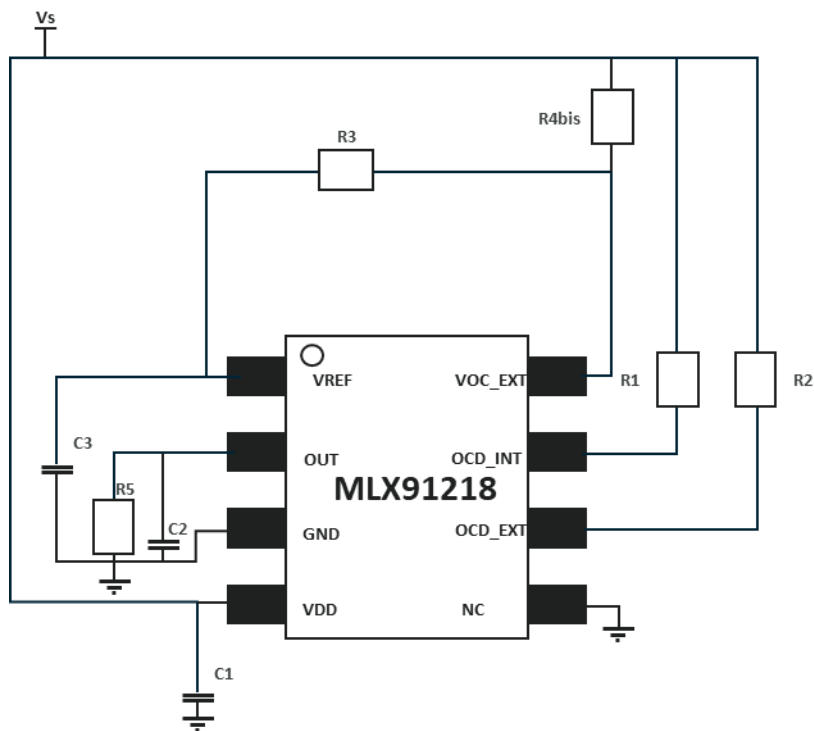

Figure 8: Application Diagram for Unidirectional External OCD

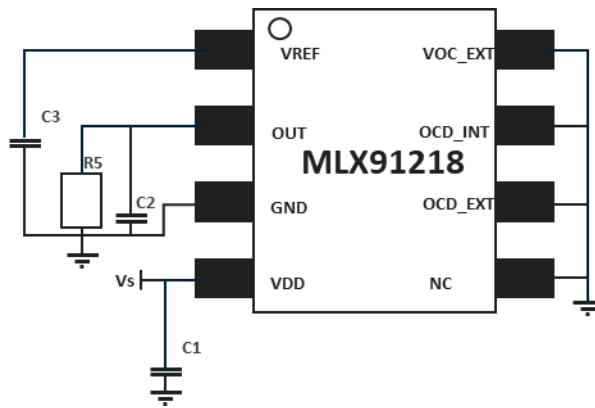

Figure 9: Application Diagram without OCD functionalities

Part	Description	Value	Unit
C ₁	Supply capacitor, EMI, ESD	47	nF
C ₂	Decoupling, EMI, ESD	4.7	nF
C ₃	Decoupling, EMI, ESD	47	nF
R ₁	Internal OCD resistor	10	kΩ
R ₂	External OCD resistor	10	kΩ
R ₃ + R ₄ or R ₃ + R _{4_BIS}	External OCD Resistor	>200	kΩ
R ₄ or R _{4_BIS}	External OCD Resistor	custom	-
R ₅	Pull-down resistance	>10	kΩ

Table 19: Resistor and capacitor values

14.1. Resistance on reference voltage pin

The resistance connected to the reference pin should be large enough to limit the current. Figure 10 shows an example of the case when the resistance on the reference pin is too low. The measured V_{REF} will be equal to $V_{REF} = V_{REFINT} \times \frac{R_{EXT}}{R_{EXT} + R_{REF}} = 1.25V$. Therefore, the current I_{REF} will be equal to $I_{REF} = \frac{V_{REF}}{R_{EXT}} = 6.25mA$. The maximum source current on the reference pin is 0.6mA (typical value). Therefore, the current flowing will be 0.6mA, and the measured V_{REF} will be $V_{REF} = 0.6mA \times 200\Omega = 0.12V$. To conclude, to measure the correct reference voltage, it is important to have the resistance on the reference pin larger than the internal resistance, normally larger than 200kΩ.

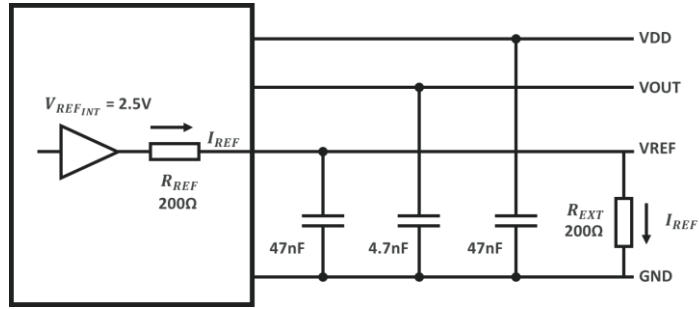

Figure 10: Case when the external resistance on reference pin is low.

15. Standard Information

Our products are classified and qualified regarding soldering technology, solderability and moisture sensitivity level according to standards in place in Semiconductor industry.

Soldering of SMDs (Surface Mount DeVICES)

For Surface Mounted Devices (SMD, as defined according to JEDEC norms), the only applicable soldering method is reflow. For more information, read the application note **Soldering for Surface Mount Technology (SMT)** at the link <https://media.melexis.com/-/media/files/documents/application-notes/handling-and-assembly/guidelines-surface-mount-technology-smt-soldering-application-note-melexis.pdf>.

Lead pre-forming of THDs (Surface Mount DeVICES)

THD lead pre-forming (cutting and/or bending) is applicable under strict compliance with Melexis Guidelines for lead forming of SIP Hall Sensors. For more information, read the application note **Lead forming of Hall sensors in SIP packages** at the link <https://www.melexis.com/en/tech-info/ic-handling-and-assembly/lead-forming>.

Soldering of THDs (Surface Mount DeVICES)

For Through Hole Devices (THD), the applicable soldering methods are reflow, wave, selective wave and robot point-to-point. For more information, read the application note **Soldering of Through Hole Devices (THD)** at the link <https://media.melexis.com/-/media/files/documents/application-notes/handling-and-assembly/guidelines-through-hole-device-thd-soldering-application-note-melexis.pdf?ts=20211210t1158483507>.

Soldering on PCB

Melexis products soldering on PCB should be conducted according to the requirements of IPC/JEDEC and J-STD-001. Solder quality acceptance should follow the requirements of IPC-A-610.

Environmental information

Melexis is contributing to global environmental conservation by promoting **lead free** solutions. For more information on qualifications of **RoHS** compliant products (RoHS = European directive on the Restriction Of the use of certain Hazardous Substances) please visit the quality page on our website (<https://www.melexis.com/en/quality-environment>).

16. ESD Precautions

Electronic semiconductor products are sensitive to Electro Static Discharge (ESD).
 Always observe Electro Static Discharge control procedures whenever handling semiconductor products.

17. Packaging information

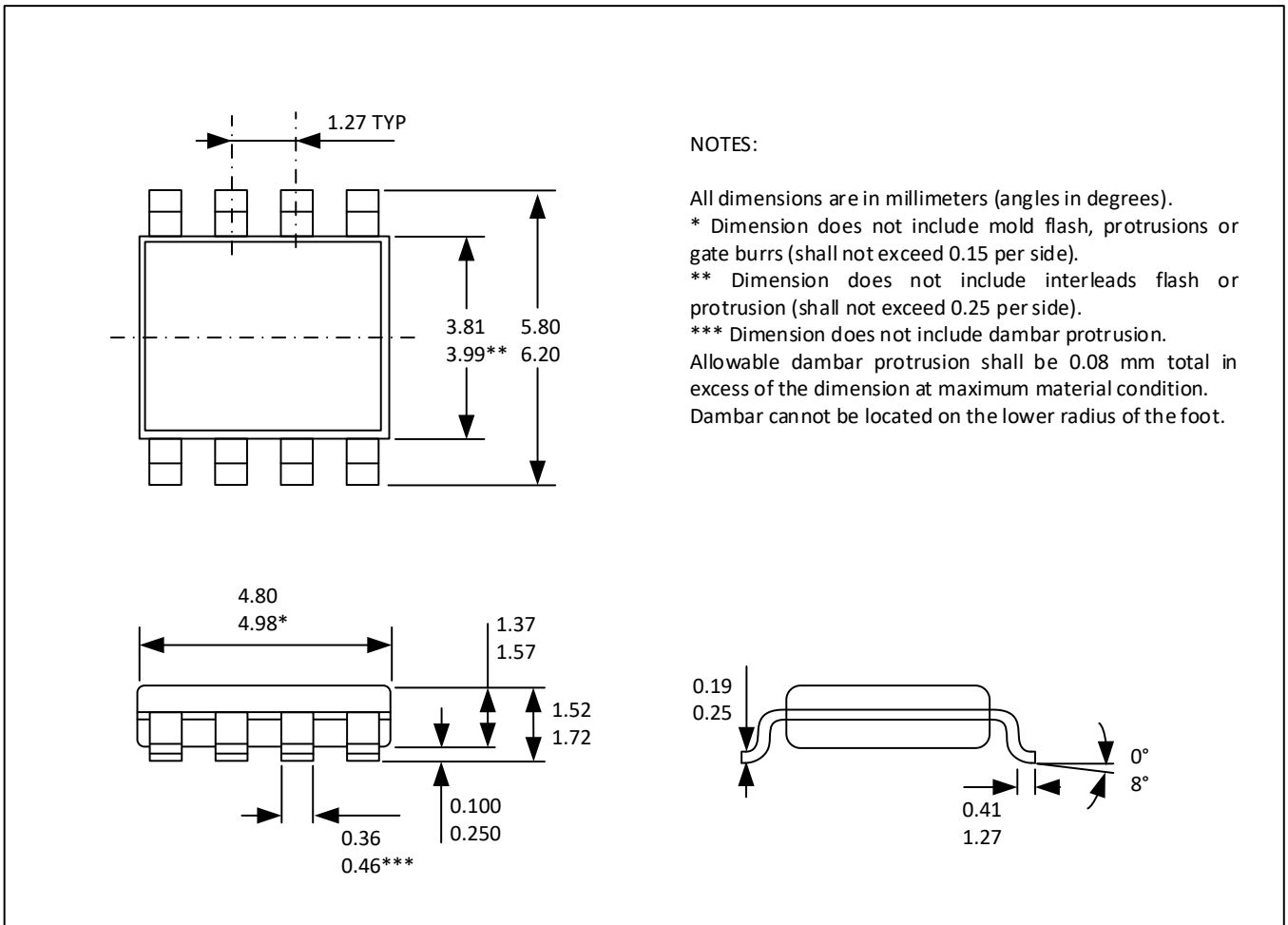
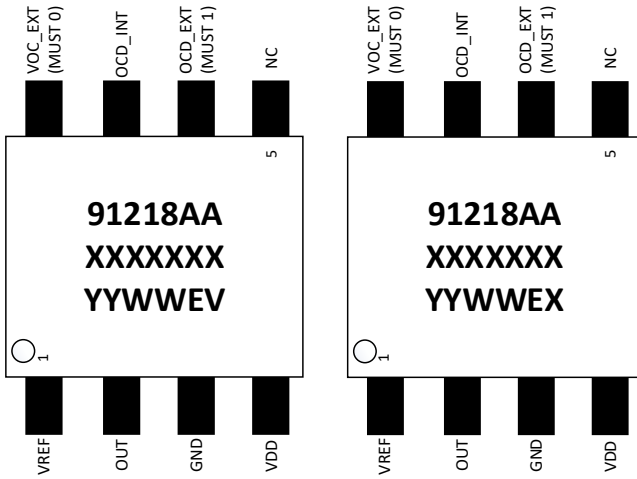

Figure 11: SOIC8 - Package Information

17.1. SOIC-8 Pinout and Marking

Very High Field Version

Extra High Field Version



Marking description:

- 1st line: 91218AA - product and product revision
- 2nd line: XXXXXXX - wafer LOT number
- 3rd line: YY..... - assembly LOT year
- 3rd line: ...WW..... - assembly LOT week
- 3rd line:EV - very high field version
- 3rd line:EX - extra high field version

Figure 12: SOIC8 - Pinout and marking

17.2. Hall plate position

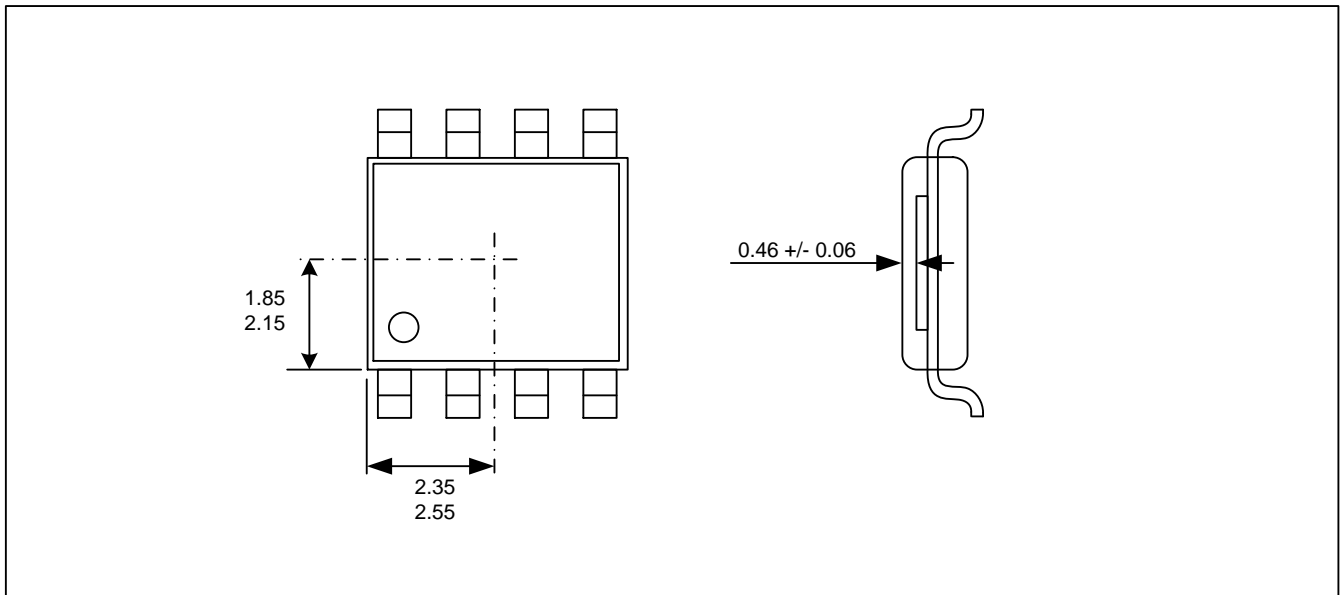

Figure 13: Hall plate position

17.3. IMC Position and sensor active measurement direction

IMC size not at scale, for representation only

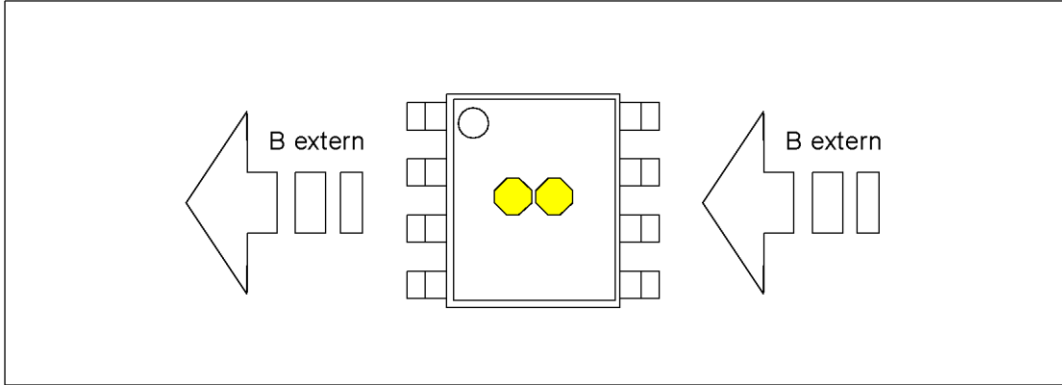

Figure 14: IMC position and geometry very high-field version

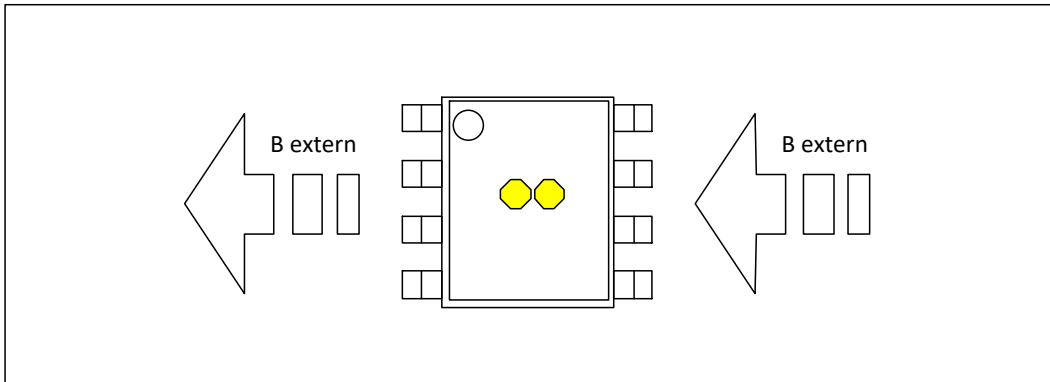

Figure 15: IMC position and geometry extra high-field version

18. Contact

For additional information, please contact our Direct Sales team and get help for your specific needs:

Europe, Africa	Email : sales_europe@melexis.com
Americas	Email : sales_usa@melexis.com
Asia	Email : sales_asia@melexis.com

19. Disclaimer

The content of this document is believed to be correct and accurate. However, the content of this document is furnished "as is" for informational use only and no representation, nor warranty is provided by Melexis about its accuracy, nor about the results of its implementation. Melexis assumes no responsibility or liability for any errors or inaccuracies that may appear in this document. Customer will follow the practices contained in this document under its sole responsibility. This documentation is in fact provided without warranty, term, or condition of any kind, either implied or expressed, including but not limited to warranties of merchantability, satisfactory quality, non-infringement, and fitness for purpose. Melexis, its employees and agents and its affiliates' and their employees and agents will not be responsible for any loss, however arising, from the use of, or reliance on this document. Notwithstanding the foregoing, contractual obligations expressly undertaken in writing by Melexis prevail over this disclaimer.

This document is subject to change without notice, and should not be construed as a commitment by Melexis. Therefore, before placing orders or prior to designing the product into a system, users or any third party should obtain the latest version of the relevant information. Users or any third party must determine the suitability of the product described in this document for its application, including the level of reliability required and determine whether it is fit for a particular purpose.

This document as well as the product here described may be subject to export control regulations. Be aware that export might require a prior authorization from competent authorities. The product is not designed, authorized or warranted to be suitable in applications requiring extended temperature range and/or unusual environmental requirements. High reliability applications, such as medical life-support or life-sustaining equipment or avionics application are specifically excluded by Melexis. The product may not be used for the following applications subject to export control regulations: the development, production, processing, operation, maintenance, storage, recognition or proliferation of:

- 1. chemical, biological or nuclear weapons, or for the development, production, maintenance or storage of missiles for such weapons;*
- 2. civil firearms, including spare parts or ammunition for such arms;*
- 3. defense related products, or other material for military use or for law enforcement;*
- 4. any applications that, alone or in combination with other goods, substances or organisms could cause serious harm to persons or goods and that can be used as a means of violence in an armed conflict or any similar violent situation.*

No license nor any other right or interest is granted to any of Melexis' or third party's intellectual property rights.

If this document is marked "restricted" or with similar words, or if in any case the content of this document is to be reasonably understood as being confidential, the recipient of this document shall not communicate, nor disclose to any third party, any part of the document without Melexis' express written consent. The recipient shall take all necessary measures to apply and preserve the confidential character of the document. In particular, the recipient shall (i) hold document in confidence with at least the same degree of care by which it maintains the confidentiality of its own proprietary and confidential information, but no less than reasonable care; (ii) restrict the disclosure of the document solely to its employees, agents, professional advisors and contractors for the purpose for which this document was received, on a strictly need to know basis and providing that such persons to whom the document is disclosed are bound by confidentiality terms substantially similar to those in this disclaimer; (iii) use the document only in connection with the purpose for which this document was received, and reproduce document only to the extent necessary for such purposes; (iv) not use the document for commercial purposes or to the detriment of Melexis or its customers. The confidentiality obligations set forth in this disclaimer will have indefinite duration and in any case they will be effective for no less than 10 years from the receipt of this document.

This disclaimer will be governed by and construed in accordance with Belgian law and any disputes relating to this disclaimer will be subject to the exclusive jurisdiction of the courts of Brussels, Belgium.

The invalidity or ineffectiveness of any of the provisions of this disclaimer does not affect the validity or effectiveness of the other provisions. The previous versions of this document are repealed.

Melexis © - No part of this document may be reproduced without the prior written consent of Melexis. (2022)

IATF 16949 and ISO 14001 Certified

*For the latest version of this document or find your local contact, visit us at
<https://www.melexis.com/MLX91218>*