

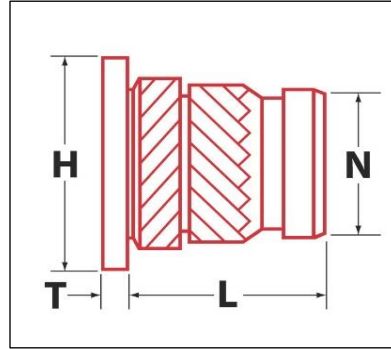

240 E. Rosecrans Avenue | Gardena, CA 90248 | (800) 234-5613 | www.ezlok.com

Ultrasonic/Heat Stake Insert for Plastic



SPECS:

Part No: FL-316-HI

Style: Straight; Flanged

Installation Method: Ultrasonic or Heat Staking

Material: Brass

For Use In: Thermoplastic

Internal Thread: 3/8-16

Overall Length/in (L+T): 0.563

Head Thickness/in (T): 0.063

Head Diameter/in (H): 0.551

Pilot Diameter/in (N): 0.465

Insert Diameter (in): 0.494

*Rec. Hole Size (in.): 0.469

* Hole size requirements may vary depending on a number of factors, including material and tools.
We recommend that you test your application prior to production.