

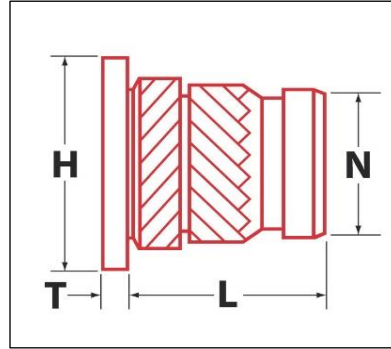

240 E. Rosecrans Avenue | Gardena, CA 90248 | (800) 234-5613 | www.ezlok.com

Ultrasonic/Heat Stake Insert for Plastic



SPECS:

Part No: FL-124-HI

Style: Straight; Flanged

Installation Method: Ultrasonic or Heat Staking

Material: Brass

For Use In: Thermoplastic

Internal Thread: 10-24

Overall Length/in (L+T): 0.418

Head Thickness/in (T): 0.043

Head Diameter/in (H): 0.312

Pilot Diameter/in (N): 0.249

Insert Diameter (in): 0.278

*Rec. Hole Size (in.): 0.252

* Hole size requirements may vary depending on a number of factors, including material and tools.
We recommend that you test your application prior to production.