

## High dV/dt Optimized XtremeSense™ TMR Coreless Current Sensor with 1 MHz Bandwidth and Programmable Gain

### FEATURES AND BENEFITS

- User-programmable field range:
  - 6 to 8 mT
  - 12 to 48 mT
- Preset magnetic field ranges:
  - 0 to 6 mT
  - 0 to 24 mT
  - ±6 mT
  - ±24 mT
  - 0 to 12 mT
  - ±48 mT
  - ±12 mT
- Optimized for high dV/dt applications
- Linear analog output voltage
- 1 MHz bandwidth
- Response time: <300 ns
- Supply voltage: 3.3 or 5.0 V
- Low noise performance
- Package options:
  - 8-lead SOIC
  - 8-lead TSSOP

### APPLICATIONS

- Solar/power inverters
- Battery management systems
- Industrial equipment
- Power utility meters
- Power conditioner
- DC/DC converters

### DESCRIPTION

The CT455 is a high-bandwidth and low-noise integrated contactless current sensor that uses Allegro patented XtremeSense TMR technology to enable high-accuracy current measurements for many consumer, enterprise, and industrial applications. The device supports two standard field ranges where the CT455 senses and translates the magnetic field into a linear analog output voltage. It achieves a total error output of less than ±1.0% over supply voltage and temperature after calibration.

The CT455 is also available in a user-programmable variant, which enables end-of-line calibration of gain and offset. While the sensor is preprogrammed to compensate for gain and offset temperature drift, the ability to adjust offset and gain relaxes mechanical tolerances during sensor mounting.

The device has less than 300 ns output response time while the current consumption is ~6.0 mA.

The CT455 is assembled in an 8-lead SOIC package and a low-profile, industry-standard 8-lead TSSOP package that are both green and RoHS compliant.

### PACKAGES:

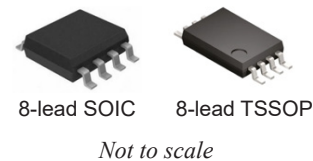

### FUNCTIONAL BLOCK DIAGRAMS

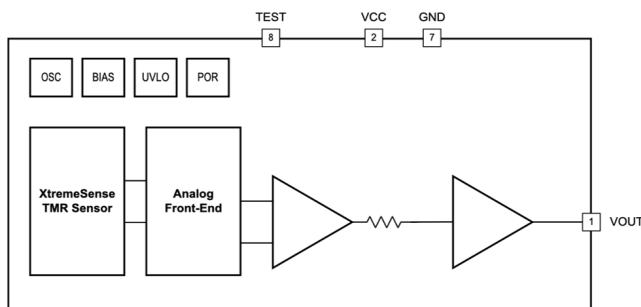

**Figure 1: CT455 Functional Block Diagram for TSSOP-8**

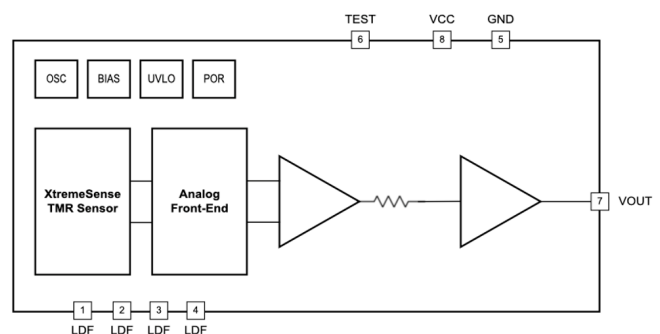

**Figure 2: CT455 Functional Block Diagram for SOIC-8**

### Table of Contents

Features and Benefits.....	1	Pinout Diagrams and Terminal Lists.....	5
Description.....	1	Electrical Characteristics.....	6
Applications.....	1	Functional Description.....	13
Packages.....	1	XtremeSense TMR Current Sensor Location.....	15
Functional Block Diagrams.....	1	Package Outline Drawings.....	16
Selection Guide.....	2	Tape and Reel Pocket Drawings and Dimensions.....	18
Evaluation Board Selection Guide.....	3	Device Markings.....	19
Absolute Maximum Ratings.....	3	Part Ordering Number Legend.....	19
Recommended Operating Conditions.....	3	Revision History.....	21
Application Diagrams.....	4		

### SELECTION GUIDE

Part Number	Polarity	Range (mT)	Supply Voltage (V)	Operating Temperature Range (°C)	Package	Packing
<b>FACTORY-CALIBRATED SENSORS</b>						
CT455-H06B3-TS08	Bipolar	±6	3.3	-40 to 125	8-lead TSSOP 3.00 mm × 6.40 mm × 1.10 mm	Tape and Reel
CT455-H06U3-TS08	Unipolar	0 to 6				
CT455-H06B5-TS08	Bipolar	±6	5.0			
CT455-H06U5-TS08	Unipolar	0 to 6				
CT455-H12B3-TS08	Bipolar	±12	3.3			
CT455-H12U3-TS08	Unipolar	0 to 12				
CT455-H12B5-TS08	Bipolar	±12	5.0			
CT455-H12U5-TS08	Unipolar	0 to 12				
CT455-H24B3-TS08	Bipolar	±24	3.3			
CT455-H24U3-TS08	Unipolar	0 to 24				
CT455-H24B5-TS08	Bipolar	±24	5.0			
CT455-H24U5-TS08	Unipolar	0 to 24				
CT455-H48B5-TS08	Bipolar	±48	5.0			
CT455-H48B5-SN08	Bipolar	±48		-40 to 125	8-lead SOIC 4.89 mm × 6.00 mm × 1.62 mm	Tape and Reel
<b>PROGRAMMABLE SENSORS</b>						
CT455-H00B3-TS08	Bipolar	±6 to ±8 and ±12 to ±48	3.3	-40 to 125	8-lead TSSOP 3.00 mm × 6.40 mm × 1.10 mm	Tape and Reel
CT455-H00U3-TS08	Unipolar					
CT455-H00B5-TS08	Bipolar	5.0				
CT455-H00U5-TS08	Unipolar					
CT455-H00B5-SN08	Bipolar	±6 to ±8 and ±12 to ±48	5.0	-40 to 125	8-lead SOIC 4.89 mm × 6.00 mm × 1.62 mm	Tape and Reel

### EVALUATION BOARD SELECTION GUIDE

Part Number	Magnetic Field Range (mT)	Supply Voltage (V)	Current Carrying Conductor	Operating Temperature Range (°C)
CTD455-BB-06B3	±6	3.3	Busbar	-40 to 125
CTD455-BB-06B5	±6	5.0		
CTD455-PT-06B3	±6	3.3	PCB Trace	
CTD455-PT-06B5	±6	5.0		

### ABSOLUTE MAXIMUM RATINGS [1]

Characteristic	Symbol	Notes	Rating	Unit
Supply Voltage Strength	$V_{CC}$		-0.3 to 6.0	V
Analog Input/Output Pins Maximum Voltage	$V_{I/O}$		-0.3 to $V_{CC} + 0.3$ [2]	V
Electrostatic Discharge Protection Level	ESD	Human Body Model (HBM) per JESD22-A114	±2.0 (min)	kV
		Charged Device Model (CDM) per JESD22-C101	±0.5 (min)	kV
Junction Temperature	$T_J$		-40 to 150	°C
Storage Temperature	$T_{STG}$		-65 to 155	°C
Lead Soldering Temperature	$T_L$	10 seconds	260	°C

[1] Stresses exceeding the absolute maximum ratings may damage the CT455 and may not function or be operable above the recommended operating conditions and stressing the parts to these levels is not recommended. In addition, extended exposure to stresses above the recommended operating conditions may affect device reliability. The absolute maximum ratings are stress ratings only.

[2] The lower of  $V_{CC} + 0.3$  V or 6.0 V.

### RECOMMENDED OPERATING CONDITIONS [1]

Characteristic	Symbol	Notes	Min.	Typ.	Max.	Unit
Supply Voltage Range	$V_{CC}$	5.0 $V_{CC}$ variant (-x5)	4.75	5.00	5.50	V
		3.3 $V_{CC}$ variant (-x3)	3.0	3.3	3.6	V
Output Voltage Range	$V_{OUT}$		0	-	$V_{CC}$	V
Output Current	$I_{OUT}$		-	-	±1.0	mA
Operating Ambient Temperature	$T_A$	Extended Industrial	-40	25	125	°C

[1] The Recommended Operating Conditions table defines the conditions for actual operation of the CT455. Recommended operating conditions are specified to ensure optimal performance to the specifications. Allegro does not recommend exceeding them or designing to absolute maximum ratings.

### APPLICATION DIAGRAMS

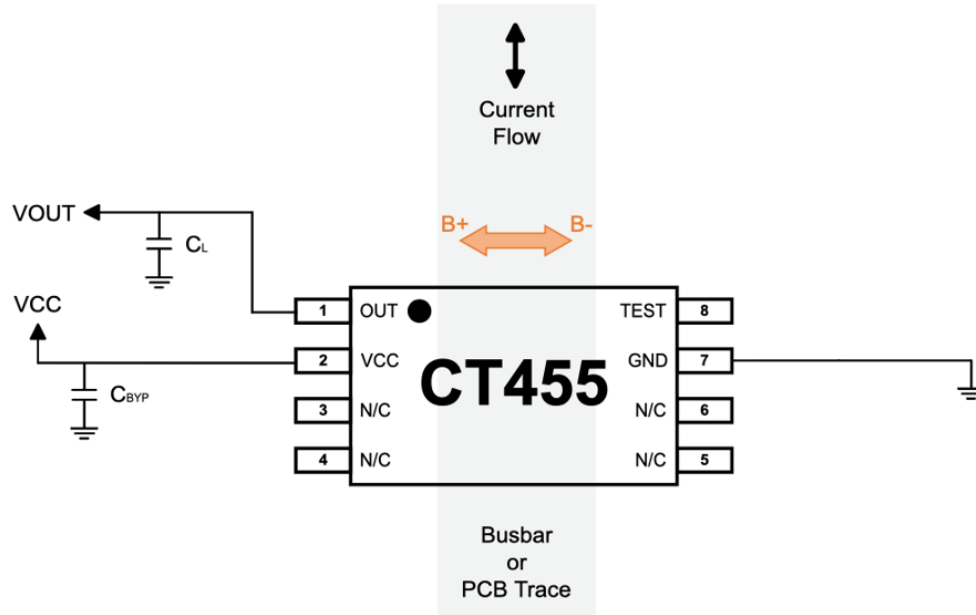

Figure 3: CT455 Application Diagram for Measuring Uniform Magnetic Field

Table 1: Recommended External Components

Component	Description	Vendor and Part Number	Min.	Typ.	Max.	Unit
$C_{BYP}$	1.0 $\mu\text{F}$ , X5R or better	Murata GRM155C81A105KA12	–	1.0	–	$\mu\text{F}$

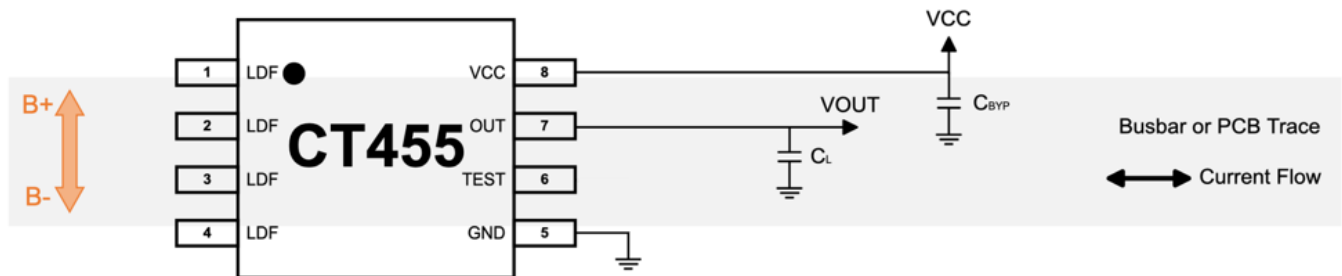

Figure 4: CT455 Application Diagram for SOIC-8

Table 2: Recommended External Components

Component	Description	Vendor and Part Number	Min.	Typ.	Max.	Unit
$C_{BYP}$	1.0 $\mu\text{F}$ , X5R or better	Murata GRM155C81A105KA12	–	1.0	–	$\mu\text{F}$

### PINOUT DIAGRAMS AND TERMINAL LISTS

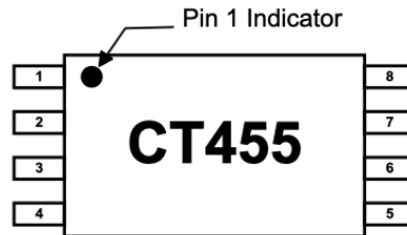

Figure 5: CT455 Pinout Diagram for 8-lead TSSOP Package (Top-Down View)

#### Terminal List

Number	Name	Function
1	OUT	Analog output voltage that represents the measured current/field.
2	VCC	Supply voltage.
3, 4, 5, 6	NC	No connect (do not use).
7	GND	Ground.
8	TEST	Pin used for calibration. Connect to Ground if not used.

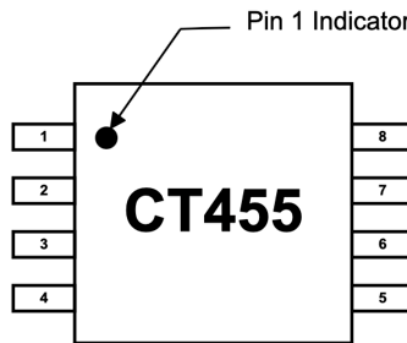

Figure 6: CT455 Pinout Diagram for 8-lead SOIC Package (Top-Down View)

#### Terminal List

Number	Name	Function
1, 2, 3, 4	LDF	Lead frame Pin – A single (1) LDF pin should be connected to GND. The other three (3) LDF pins should be left unconnected to avoid ground loops through the lead frame.
5	GND	Ground.
6	TEST	Pin used for calibration. Connect to Ground if not used.
7	OUT	Analog output voltage that represents the measured current/field.
8	VCC	Supply voltage.

**ELECTRICAL CHARACTERISTICS:**  $V_{CC} = 3.0$  to  $3.6$  V or  $4.75$  to  $5.50$  V,  $T_A = -40^\circ\text{C}$  to  $125^\circ\text{C}$ ,  $C_{BYP} = 1.0$   $\mu\text{F}$ , unless otherwise specified; typical values are  $V_{CC} = 3.3$  or  $5.00$  V and  $T_A = 25^\circ\text{C}$

Characteristics	Symbol	Test Conditions	Min.	Typ.	Max.	Unit	
<b>POWER SUPPLIES</b>							
Supply Current	$I_{CC}$	$f_{BW} = 1$ MHz, no load, $B_{OP} = 0$ mT	–	6.0	9.0	mA	
OUT Maximum Drive Capability	$I_{OUT}$	OUT covers 10% to 90% of $V_{CC}$ span	–1.0	–	+1.0	mA	
OUT Capacitive Load	$C_{L\_OUT}$		–	–	100	pF	
OUT Resistive Load	$R_{L\_OUT}$		–	100	–	k $\Omega$	
Power Supply Rejection Ratio [1]	PSRR		–	35	–	dB	
Sensitivity Power Supply Rejection Ratio [1]	SPSRR		–	35	–	dB	
Offset Power Supply Rejection Ratio [1]	OPSRR		–	40	–	dB	
Bandwidth [1]	$f_{BW}$	Small Signal = –3 dB	–	1.0	–	MHz	
<b>ANALOG OUTPUT (OUT)</b>							
OUT Voltage Linear Range	$V_{OUT}$	5.0 $V_{CC}$ variant (-x5)	0.50	–	4.50	V	
		3.3 $V_{CC}$ variant (-x3)	0.65	–	2.65	V	
Output High Saturation Voltage	$V_{OUT\_SAT}$	$T_A = 25^\circ\text{C}$	$V_{CC} - 0.30$	$V_{CC} - 0.25$	–	V	
Voltage Output Quiescent	$V_{OQ}$	$T_A = 25^\circ\text{C}$ , $B_{OP} = 0$ mT	5.0 $V_{CC}$ , bipolar (-xB5)	2.490	2.500	2.510	V
			5.0 $V_{CC}$ , unipolar (-xU5)	0.495	0.500	0.505	V
			3.3 $V_{CC}$ , bipolar (-xB3)	1.645	1.650	1.655	V
			3.3 $V_{CC}$ , unipolar (-xU3)	0.645	0.650	0.655	V
<b>TIMINGS</b>							
Power-On Time	$t_{ON}$	$V_{CC} \geq 4.0$ V variant (-x5), $V_{CC} \geq 2.5$ V variant (-x3)	–	100	200	$\mu\text{s}$	
Rise Time [1]	$t_{RISE}$	$B_{OP} = B_{RNG(MAX)}$ , $T_A = 25^\circ\text{C}$ , $C_L = 100$ pF	–	200	–	ns	
Response Time [1]	$t_{RESPONSE}$	$B_{OP} = B_{RNG(MAX)}$ , $T_A = 25^\circ\text{C}$ , $C_L = 100$ pF	–	300	–	ns	
Propagation Delay [1]	$t_{DELAY}$	$B_{OP} = B_{RNG(MAX)}$ , $T_A = 25^\circ\text{C}$ , $C_L = 100$ pF	–	250	–	ns	
<b>PROTECTION</b>							
Undervoltage Lockout	$V_{UVLO}$	Rising $V_{CC}$	–	2.50	–	V	
		Falling $V_{CC}$	–	2.45	–	V	
UVLO Hysteresis	$V_{UV\_HYS}$		–	50	–	mV	
<b>LIFETIME DRIFT</b>							
Total Output Error Lifetime Drift [1]	$E_{TOT\_DRIFT}$		–	$\pm 0.35$	1%	% FS	

[1] Guaranteed by design and characterization; not tested in production.

### ELECTRICAL CHARACTERISTICS

$V_{CC} = 3.3$  or  $5.0$  V,  $T_A = 25^\circ\text{C}$ , and  $C_{BYP} = 1.0 \mu\text{F}$  (unless otherwise specified)

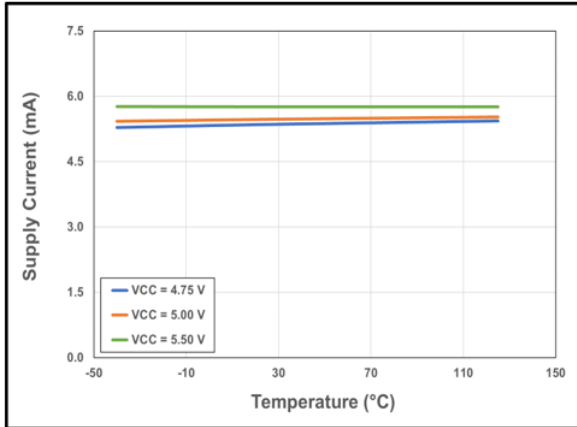

Figure 7: 5.0  $V_{CC}$  variant (-x5) Supply Current vs. Temperature vs. Supply Voltage

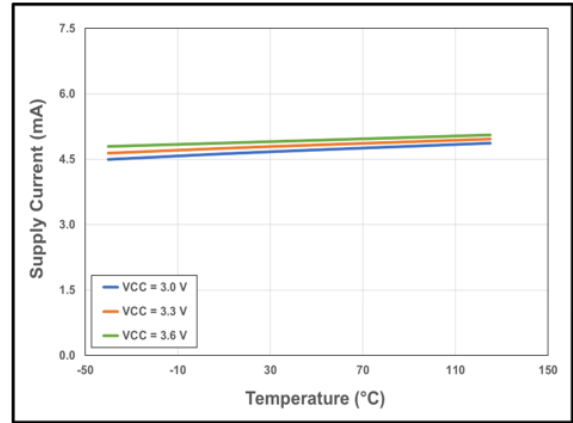

Figure 8: 3.3  $V_{CC}$  variant (-x3) Supply Current vs. Temperature vs. Supply Voltage

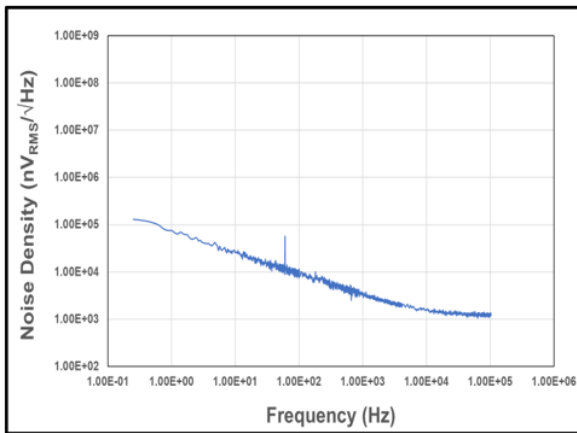

Figure 9: Noise Density vs. Frequency

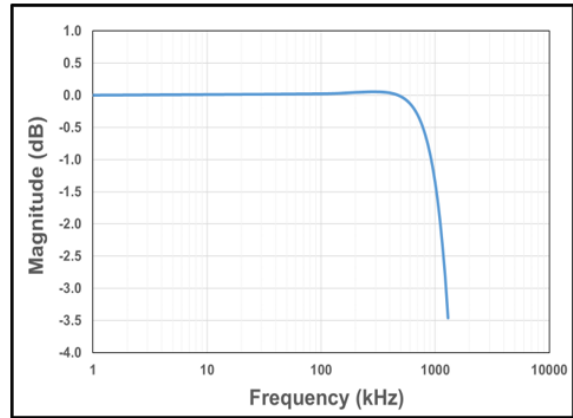

Figure 10: CT455 Bandwidth

**CT455-x06Ux: 0 to 6 mT – ELECTRICAL CHARACTERISTICS:**  $V_{CC} = 3.0$  to  $3.6$  V or  $4.75$  to  $5.50$  V,  $T_A = -40^\circ\text{C}$  to  $125^\circ\text{C}$ ,  $C_{BYP} = 1.0$   $\mu\text{F}$ , unless otherwise specified; typical values are  $V_{CC} = 3.3$  or  $5.00$  V and  $T_A = 25^\circ\text{C}$

Characteristics	Symbol	Test Conditions	Min.	Typ.	Max.	Unit
Magnetic Field Range	$B_{RNG}$		0	–	6	mT
Sensitivity	S	5.0 $V_{CC}$ variant (-x5)	–	666.7	–	mV/mT
		3.3 $V_{CC}$ variant (-x3)	–	333.3	–	mV/mT
Noise [1]	$e_N$	$T_A = 25^\circ\text{C}$ , $f_{BW} = 100$ kHz	–	2.45	–	$\mu\text{T}_{RMS}$
<b>OUT ACCURACY PERFORMANCE</b>						
Non-Linearity Error	$E_{LIN}$		–	$\pm 0.2$	–	% FS
Sensitivity Error	$E_{SENS}$		–	$\pm 0.3$	–	% FS
Offset Voltage	$V_{OFFSET}$	$B_{OP} = 0$ mT	–	$\pm 0.3$	–	% FS

[1] Guaranteed by design and characterization; not tested in production.

**CT455-x06Bx:  $\pm 6$  mT – ELECTRICAL CHARACTERISTICS:**  $V_{CC} = 3.0$  to  $3.6$  V or  $4.75$  to  $5.50$  V,  $T_A = -40^\circ\text{C}$  to  $125^\circ\text{C}$ ,  $C_{BYP} = 1.0$   $\mu\text{F}$ , unless otherwise specified; typical values are  $V_{CC} = 3.3$  or  $5.00$  V and  $T_A = 25^\circ\text{C}$

Characteristics	Symbol	Test Conditions	Min.	Typ.	Max.	Unit
Magnetic Field Range	$B_{RNG}$		–6	–	6	mT
Sensitivity	S	5.0 $V_{CC}$ variant (-x5)	–	333.3	–	mV/mT
		3.3 $V_{CC}$ variant (-x3)	–	166.7	–	mV/mT
Noise [1]	$e_N$	$T_A = 25^\circ\text{C}$ , $f_{BW} = 100$ kHz	–	2.77	–	$\mu\text{T}_{RMS}$
<b>OUT ACCURACY PERFORMANCE</b>						
Non-Linearity Error	$E_{LIN}$		–	$\pm 0.1$	–	% FS
Sensitivity Error	$E_{SENS}$		–	$\pm 0.3$	–	% FS
Offset Voltage	$V_{OFFSET}$	$B_{OP} = 0$ mT	–	$\pm 0.3$	–	% FS

[1] Guaranteed by design and characterization; not tested in production.



# CT455

## High dV/dt Optimized XtremeSense™ TMR Coreless Current Sensor with 1 MHz Bandwidth and Programmable Gain

**CT455-x12Ux: 0 to 12 mT – ELECTRICAL CHARACTERISTICS:**  $V_{CC} = 3.0$  to  $3.6$  V or  $4.75$  to  $5.50$  V,  $T_A = -40^\circ\text{C}$  to  $125^\circ\text{C}$ ,  $C_{BYP} = 1.0$   $\mu\text{F}$ , unless otherwise specified; typical values are  $V_{CC} = 3.3$  or  $5.00$  V and  $T_A = 25^\circ\text{C}$

Characteristics	Symbol	Test Conditions	Min.	Typ.	Max.	Unit
Magnetic Field Range	$B_{RNG}$		0	–	12	mT
Sensitivity	S	5.0 $V_{CC}$ variant (-x5)	–	333.3	–	mV/mT
		3.3 $V_{CC}$ variant (-x3)	–	166.7	–	mV/mT
Noise [1]	$e_N$	$T_A = 25^\circ\text{C}$ , $f_{BW} = 100$ kHz	–	3.90	–	$\mu\text{T}_{RMS}$
<b>OUT ACCURACY PERFORMANCE</b>						
Non-Linearity Error	$E_{LIN}$		–	$\pm 0.2$	–	% FS
Sensitivity Error	$E_{SENS}$		–	$\pm 0.3$	–	% FS
Offset Voltage	$V_{OFFSET}$	$B_{OP} = 0$ mT	–	$\pm 0.3$	–	% FS

[1] Guaranteed by design and characterization; not tested in production.

**CT455-x12Bx:  $\pm 12$  mT – ELECTRICAL CHARACTERISTICS:**  $V_{CC} = 3.0$  to  $3.6$  V or  $4.75$  to  $5.50$  V,  $T_A = -40^\circ\text{C}$  to  $125^\circ\text{C}$ ,  $C_{BYP} = 1.0$   $\mu\text{F}$ , unless otherwise specified; typical values are  $V_{CC} = 3.3$  or  $5.00$  V and  $T_A = 25^\circ\text{C}$

Characteristics	Symbol	Test Conditions	Min.	Typ.	Max.	Unit
Magnetic Field Range	$B_{RNG}$		-12	–	12	mT
Sensitivity	S	5.0 $V_{CC}$ variant (-x5)	–	166.7	–	mV/mT
		3.3 $V_{CC}$ variant (-x3)	–	83.3	–	mV/mT
Noise [1]	$e_N$	$T_A = 25^\circ\text{C}$ , $f_{BW} = 100$ kHz	–	4.50	–	$\mu\text{T}_{RMS}$
<b>OUT ACCURACY PERFORMANCE</b>						
Non-Linearity Error	$E_{LIN}$		–	$\pm 0.1$	–	% FS
Sensitivity Error	$E_{SENS}$		–	$\pm 0.3$	–	% FS
Offset Voltage	$V_{OFFSET}$	$B_{OP} = 0$ mT	–	$\pm 0.3$	–	% FS

[1] Guaranteed by design and characterization; not tested in production.

# CT455

## High dV/dt Optimized XtremeSense™ TMR Coreless Current Sensor with 1 MHz Bandwidth and Programmable Gain

**CT455-x24Ux: 0 to 24 mT – ELECTRICAL CHARACTERISTICS:**  $V_{CC} = 3.0$  to  $3.6$  V or  $4.75$  to  $5.50$  V,  $T_A = -40^\circ\text{C}$  to  $125^\circ\text{C}$ ,  $C_{BYP} = 1.0$   $\mu\text{F}$ , unless otherwise specified; typical values are  $V_{CC} = 3.3$  or  $5.00$  V and  $T_A = 25^\circ\text{C}$

Characteristics	Symbol	Test Conditions	Min.	Typ.	Max.	Unit
Magnetic Field Range	$B_{RNG}$		0	–	24	mT
Sensitivity	S	5.0 $V_{CC}$ variant (-x5)	–	166.7	–	mV/mT
		3.3 $V_{CC}$ variant (-x3)	–	83.3	–	mV/mT
Noise [1]	$e_N$	$T_A = 25^\circ\text{C}$ , $f_{BW} = 100$ kHz	–	2.77	–	$\mu\text{T}_{RMS}$
<b>OUT ACCURACY PERFORMANCE</b>						
Non-Linearity Error [1]	$E_{LIN}$		–	$\pm 0.3$	–	% FS
Sensitivity Error [1]	$E_{SENS}$		–	$\pm 0.3$	–	% FS
Offset Voltage [1]	$V_{OFFSET}$	$B_{OP} = 0$ mT	–	$\pm 0.3$	–	% FS

[1] Guaranteed by design and characterization; not tested in production.

**CT455-x24Bx:  $\pm 24$  mT – ELECTRICAL CHARACTERISTICS:**  $V_{CC} = 3.0$  to  $3.6$  V or  $4.75$  to  $5.50$  V,  $T_A = -40^\circ\text{C}$  to  $125^\circ\text{C}$ ,  $C_{BYP} = 1.0$   $\mu\text{F}$ , unless otherwise specified; typical values are  $V_{CC} = 3.3$  or  $5.00$  V and  $T_A = 25^\circ\text{C}$

Characteristics	Symbol	Test Conditions	Min.	Typ.	Max.	Unit
Magnetic Field Range	$B_{RNG}$		-24	–	24	mT
Sensitivity	S	5.0 $V_{CC}$ variant (-x5)	–	83.3	–	mV/mT
		3.3 $V_{CC}$ variant (-x3)	–	41.6	–	mV/mT
Noise [1]	$e_N$	$T_A = 25^\circ\text{C}$ , $f_{BW} = 100$ kHz	–	4.56	–	$\mu\text{T}_{RMS}$
<b>OUT ACCURACY PERFORMANCE</b>						
Non-Linearity Error [1]	$E_{LIN}$		–	$\pm 0.1$	–	% FS
Sensitivity Error [1]	$E_{SENS}$		–	$\pm 0.3$	–	% FS
Offset Voltage [1]	$V_{OFFSET}$	$B_{OP} = 0$ mT	–	$\pm 0.3$	–	% FS

[1] Guaranteed by design and characterization; not tested in production.

**CT455-x48B5:  $\pm 48$  mT – ELECTRICAL CHARACTERISTICS:**  $V_{CC} = 4.75$  to  $5.50$  V,  $T_A = -40^\circ\text{C}$  to  $125^\circ\text{C}$ ,  $C_{BYP} = 1.0$   $\mu\text{F}$ , unless otherwise specified; typical values are  $V_{CC} = 5.00$  V and  $T_A = 25^\circ\text{C}$

Characteristics	Symbol	Test Conditions	Min.	Typ.	Max.	Unit
Magnetic Field Range	$B_{RNG}$		-48	–	48	mT
Sensitivity	S	5.0 $V_{CC}$ variant (-x5)	–	41.5	–	mV/mT
<b>OUT ACCURACY PERFORMANCE</b>						
Non-Linearity Error [1]	$E_{LIN}$		–	$\pm 0.1$	–	% FS
Sensitivity Error [1]	$E_{SENS}$		–	$\pm 0.3$	–	% FS
Offset Voltage [1]	$V_{OFFSET}$	$B_{OP} = 0$ mT	–	$\pm 0.3$	–	% FS

[1] Guaranteed by design and characterization; not tested in production.

**CT455-x00Ux: Programmable Gain – ELECTRICAL CHARACTERISTICS:**  $V_{CC} = 3.0$  to  $3.6$  V or  $4.75$  to  $5.50$  V,  $T_A = -40^\circ\text{C}$  to  $125^\circ\text{C}$ ,  $C_{BYP} = 1.0$   $\mu\text{F}$ , unless otherwise specified; typical values are  $V_{CC} = 3.3$  or  $5.00$  V and  $T_A = 25^\circ\text{C}$

Characteristics	Symbol	Test Conditions	Min.	Typ.	Max.	Unit
Programmable Magnetic Field Range	$B_{PRNG}$		6	–	8	mT
			12	–	48	mT
Maximum Programmable Sensitivity	$S_{P_{MAX}}$	5.0 $V_{CC}$ variant (-x5)	–	666.7	–	mV/mT
		3.3 $V_{CC}$ variant (-x3)	–	333.3	–	mV/mT
Minimum Programmable Sensitivity	$S_{P_{MIN}}$	5.0 $V_{CC}$ variant (-x5)	–	166.7	–	mV/mT
		3.3 $V_{CC}$ variant (-x3)	–	83.4	–	mV/mT
<b>OUT ACCURACY PERFORMANCE</b>						
Non-Linearity Error	$E_{LIN}$		–	$\pm 0.3$	–	% FS
Sensitivity Error	$E_{SENS}$		–	$\pm 0.3$	–	% FS
Offset Voltage	$V_{OFFSET}$	$B_{OP} = 0$ mT	–	$\pm 0.3$	–	% FS

[1] Guaranteed by design and characterization; not tested in production.

**CT455-x00Bx: Programmable Gain – ELECTRICAL CHARACTERISTICS:**  $V_{CC} = 3.0$  to  $3.6$  V or  $4.75$  to  $5.50$  V,  $T_A = -40^\circ\text{C}$  to  $125^\circ\text{C}$ ,  $C_{BYP} = 1.0$   $\mu\text{F}$ , unless otherwise specified; typical values are  $V_{CC} = 3.3$  or  $5.00$  V and  $T_A = 25^\circ\text{C}$

Characteristics	Symbol	Test Conditions	Min.	Typ.	Max.	Unit
Programmable Magnetic Field Range	$B_{PRNG}$		$\pm 6$	–	$\pm 8$	mT
			$\pm 12$	–	$\pm 48$	mT
Maximum Programmable Sensitivity	$S_{P_{MAX}}$	5.0 $V_{CC}$ variant (-x5)	–	333.3	–	mV/mT
		3.3 $V_{CC}$ variant (-x3)	–	166.7	–	mV/mT
Minimum Programmable Sensitivity	$S_{P_{MIN}}$	5.0 $V_{CC}$ variant (-x5)	–	83.4	–	mV/mT
		3.3 $V_{CC}$ variant (-x3)	–	41.7	–	mV/mT
<b>OUT ACCURACY PERFORMANCE</b>						
Non-Linearity Error	$E_{LIN}$		–	$\pm 0.2$	–	% FS
Sensitivity Error	$E_{SENS}$		–	$\pm 0.3$	–	% FS
Offset Voltage	$V_{OFFSET}$	$B_{OP} = 0$ mT	–	$\pm 0.3$	–	% FS

[1] Guaranteed by design and characterization; not tested in production.

### Calibration Description

The CT455-x00MR is factory-trimmed for sensitivity and offset temperature drift. The sensor provides the ability to adjust gain to allow for all the mechanical tolerances during manufacturing. Gain calibration is recommended to be performed at room temperature ( $25^\circ\text{C}$ ) using the Allegro CTC4000 Calibration Box.

### ELECTRICAL CHARACTERISTICS

$V_{CC} = 5.0\text{ V}$  and  $C_{BYP} = 1.0\ \mu\text{F}$

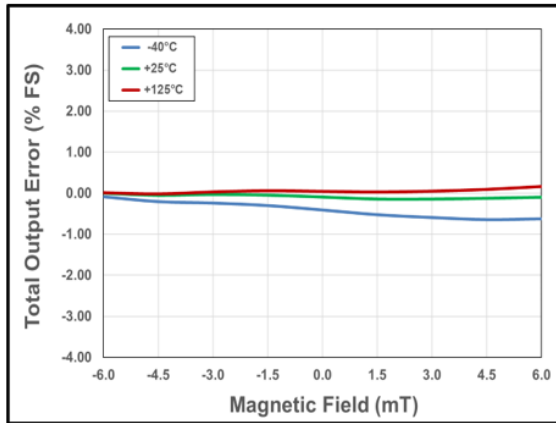

Figure 11: CT455-x06B5x Total Output Error vs. B Field

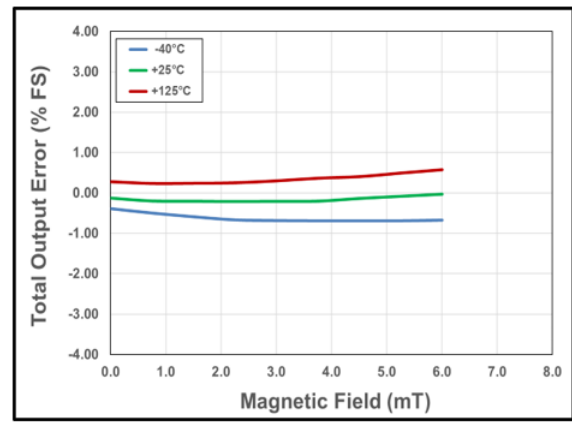

Figure 12: CT455-x06U5x Total Output Error vs. B Field

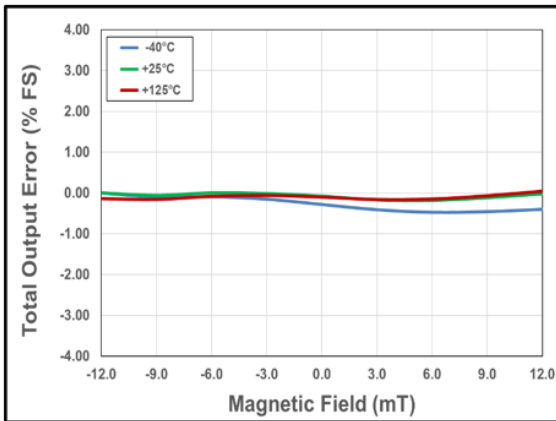

Figure 13: CT455-x12B5x Total Output Error vs. B Field

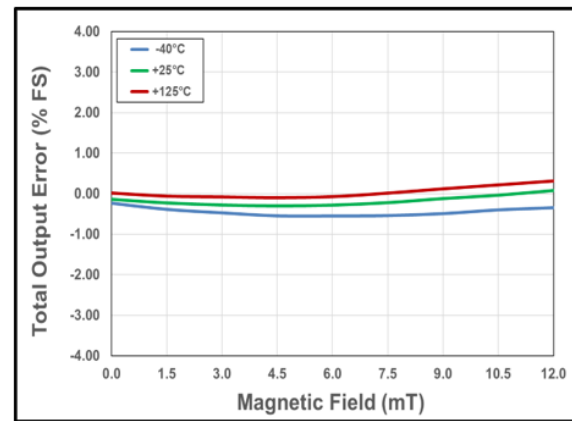

Figure 14: CT455-x12U5x Total Output Error vs. B Field

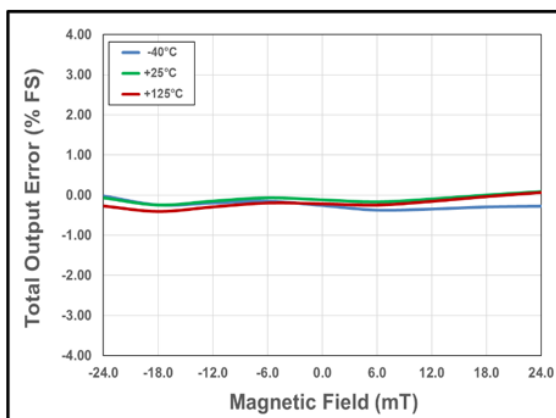

Figure 15: CT455-x24B5x Total Output Error vs. B Field

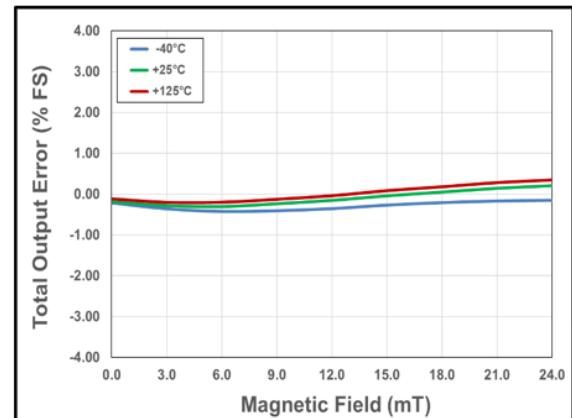

Figure 16: CT455-x24U5x Total Output Error vs. B Field

FUNCTIONAL DESCRIPTION

Overview

The CT455 is a very high accuracy coreless and contactless current sensor that can sense magnetic fields from 6 to 48 mT. The device has high sensitivity and a wide dynamic range with excellent accuracy (low total output error) across temperature.

The CT455 is also available in a user-programmable variant which enables end-of-line calibration of gain. While the sensor is pre-programmed to adjust sensitivity and offset temperature drift, the ability to adjust gain relaxes mechanical tolerances during sensor mounting.

When current is flowing through a busbar above or below the CT455, the XtremeSense TMR sensor inside the chip senses the field which in turn generates a differential voltage signals that then goes through the Analog Front-End (AFE) to output a current measurement as low as ±1.0% full-scale total output error (E<sub>OUT</sub>).

The chip is designed to enable a fast response time of 300 ns for the current measurement from the OUT pin as the bandwidth for the CT455 is 1.0 MHz. Even with a high bandwidth, the chip consumes a minimal amount of power.

Linear Output Current Measurement

The CT455 provides a continuous linear analog output voltage which represents the magnetic field generated by the current flowing through the busbar. The output voltage range of OUT is from 0.50 to 4.50 V with a V<sub>OQ</sub> of 0.50 and 2.50 V for unidirectional and bidirectional fields, respectively. Figure 17 illustrates the output voltage range of the OUT pin as a function of the measured field.

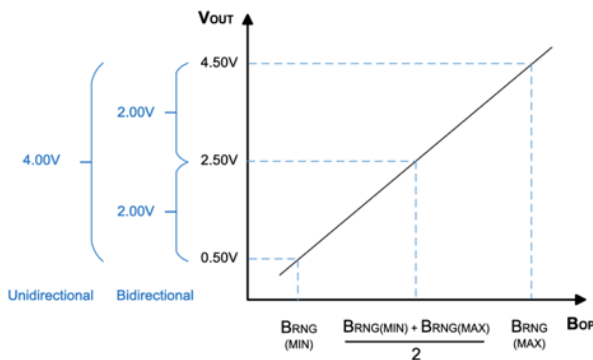

Figure 17: Linear Output Voltage Range (OUT) vs. Measured Magnetic Field (B<sub>OP</sub>)

Power-On Time (t<sub>ON</sub>)

Power-On Time (t<sub>ON</sub>) of 100 μs is the amount of time required by CT455 to start up, fully power the chip, and becoming fully operational from the moment the supply voltage is greater than the UVLO voltage. This time includes the ramp-up time and the settling time (within 10% of steady-state voltage under an applied magnetic field) after the power supply has reached the minimum V<sub>CC</sub>.

Response Time (t<sub>RESPONSE</sub>)

Response Time (t<sub>RESPONSE</sub>) of 300 ns for the CT455 is the time interval between the following terms:

1. When the primary current signal reaches 90% of its final value,
2. When the chip reaches 90% of its output corresponding to the applied current.

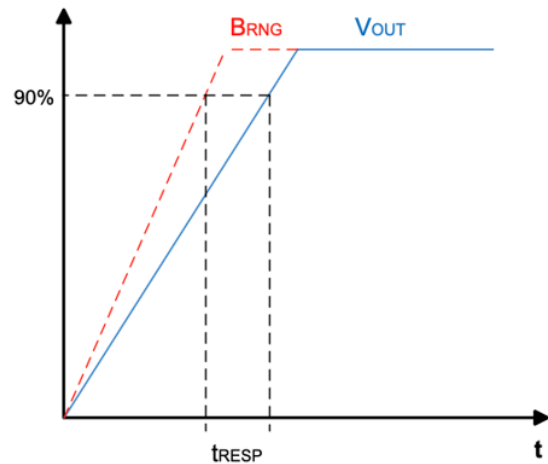

Figure 18: CT455 Response Time Curve

Rise Time (t<sub>RISE</sub>)

Rise Time (t<sub>RISE</sub>) is the time interval of when it reaches 10% and 90% of the full-scale output voltage. The t<sub>RISE</sub> of the CT455 is 200 ns.

Propagation Delay (t<sub>DELAY</sub>)

Propagation Delay (t<sub>DELAY</sub>) is the time difference between these two events:

1. When the primary current reaches 20% of its final value
2. When the chip reaches 20% of its output corresponding to the applied current.

The CT455 has a propagation delay of 250 ns.

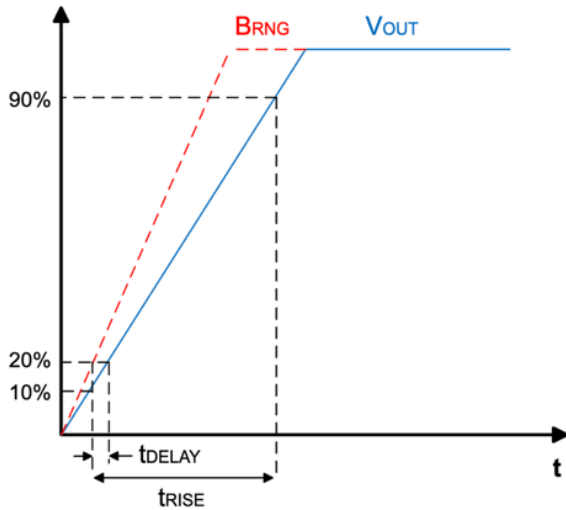

Figure 19: CT455 Propagation Delay and Rise Time Curve

### Undervoltage Lockout (UVLO)

The Undervoltage Lockout protection circuitry of the CT455 is activated when the supply voltage ( $V_{CC}$ ) falls below 2.45 V. The CT455 remains in a low quiescent state until  $V_{CC}$  rises above the UVLO threshold (2.50 V). In the condition where the  $V_{CC}$  is less than 2.45 V and UVLO is triggered, the output from the CT455 is not valid. Once  $V_{CC}$  rises above 2.5 V, then the UVLO is cleared.

### Current Sensing

The CT455 can sense and therefore measure the current by either placing a current-carrying busbar above or under the device. The chip is also sensitive enough to measure the current from a PCB trace that is routed beneath it.

### Bypass Capacitor

A single 1.0  $\mu\text{F}$  capacitor is needed for the VCC pin to reduce the noise from the power supply and other circuits. This capacitor should be placed as close as possible to the CT455 to minimize inductance and resistance between the two devices.

### XtremeSense TMR Current Sensor Location

The XtremeSense TMR current sensor location of the CT455 is shown below. All dimensions in the figures are nominal.

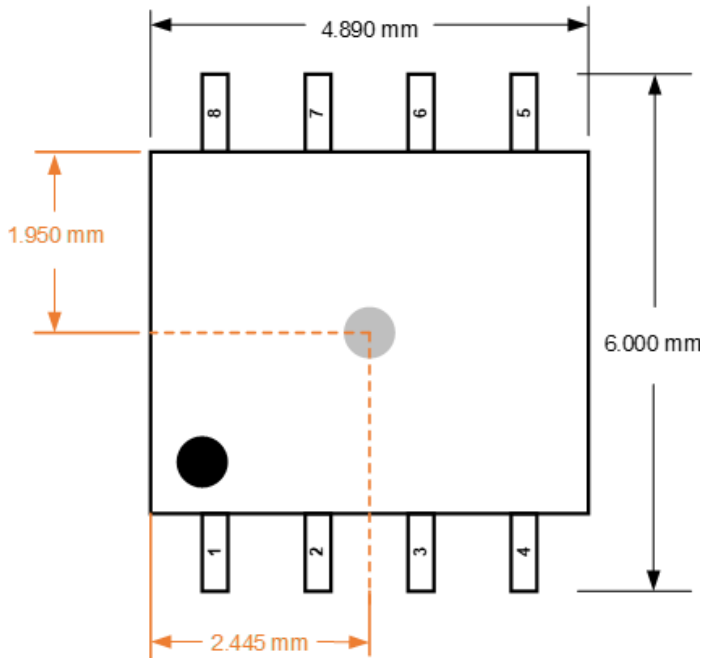

Figure 20: XtremeSense TMR Current Sensor Location in x-y Plane for CT455 in SOIC-8 Package

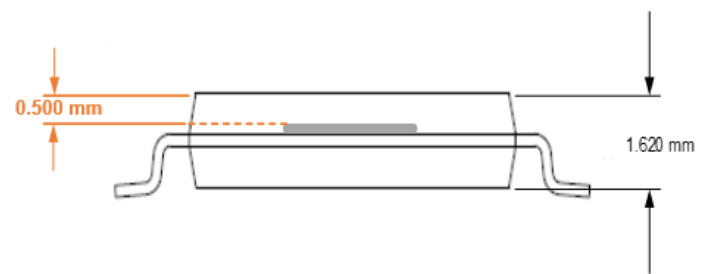

Figure 21: XtremeSense TMR Current Sensor Location in z Dimension for CT455 in SOIC-8 Package

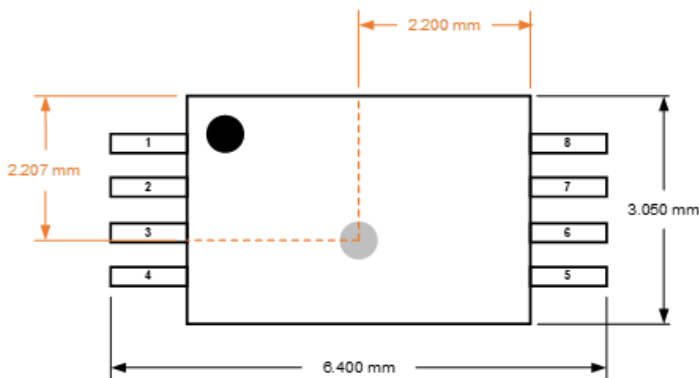

Figure 22: XtremeSense TMR Current Sensor Location in x-y Plane for CT455 in TSSOP-8 Package

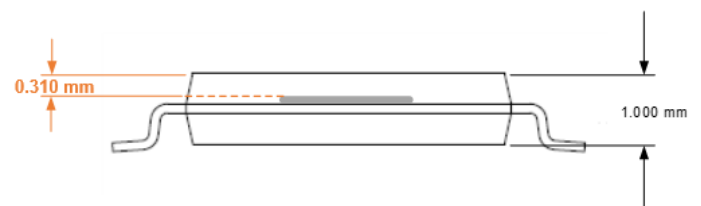

Figure 23: XtremeSense TMR Current Sensor Location in z Dimension for CT455 in TSSOP-8 Package

### PACKAGE OUTLINE DRAWINGS

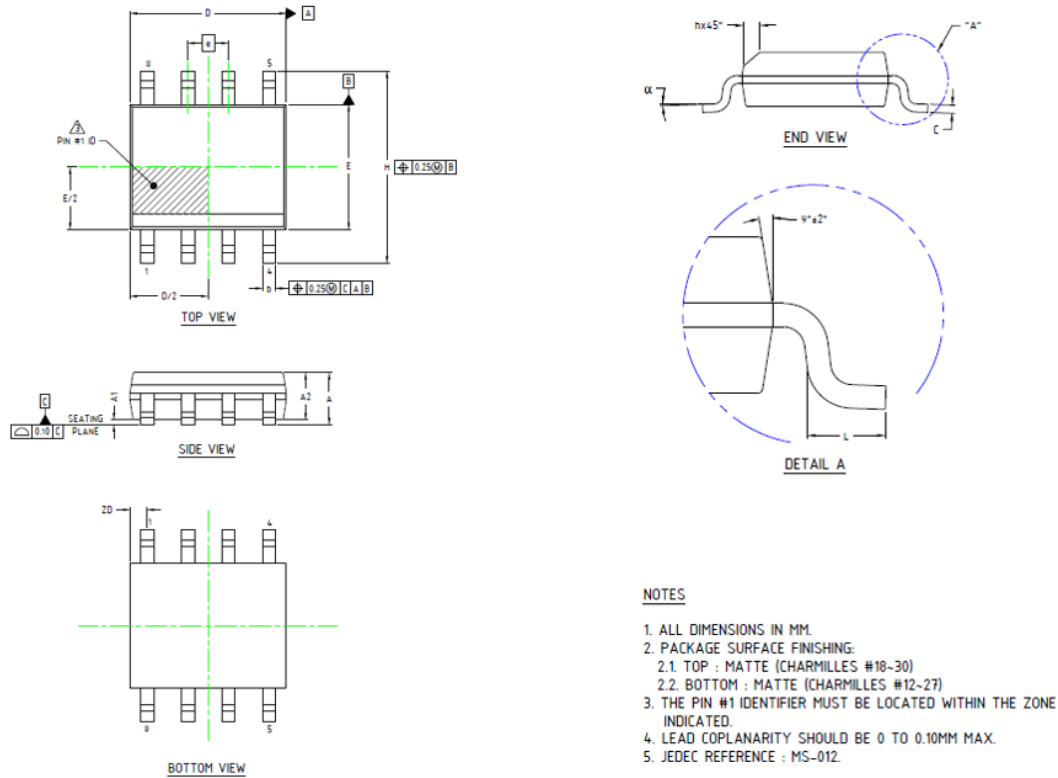

Figure 24: SOIC-8 Package Drawing and Dimensions

Table 3: CT455 SOIC-8 Package Dimensions

Symbol	Dimensions in Millimeters (mm)		
	Min.	Typ.	Max.
A1	0.10	0.18	0.25
b	0.36	0.41	0.46
C	0.19	0.22	0.25
D	4.80	4.89	4.98
E	3.81	3.90	3.99
e	1.27 BSC		
H	5.80	6.00	6.20
h	0.25	0.37	0.50
L	0.41	–	1.27
A	1.52	1.62	1.72
α	0°	–	8°
ZD	0.53 REF		
A2	1.37	1.47	1.57



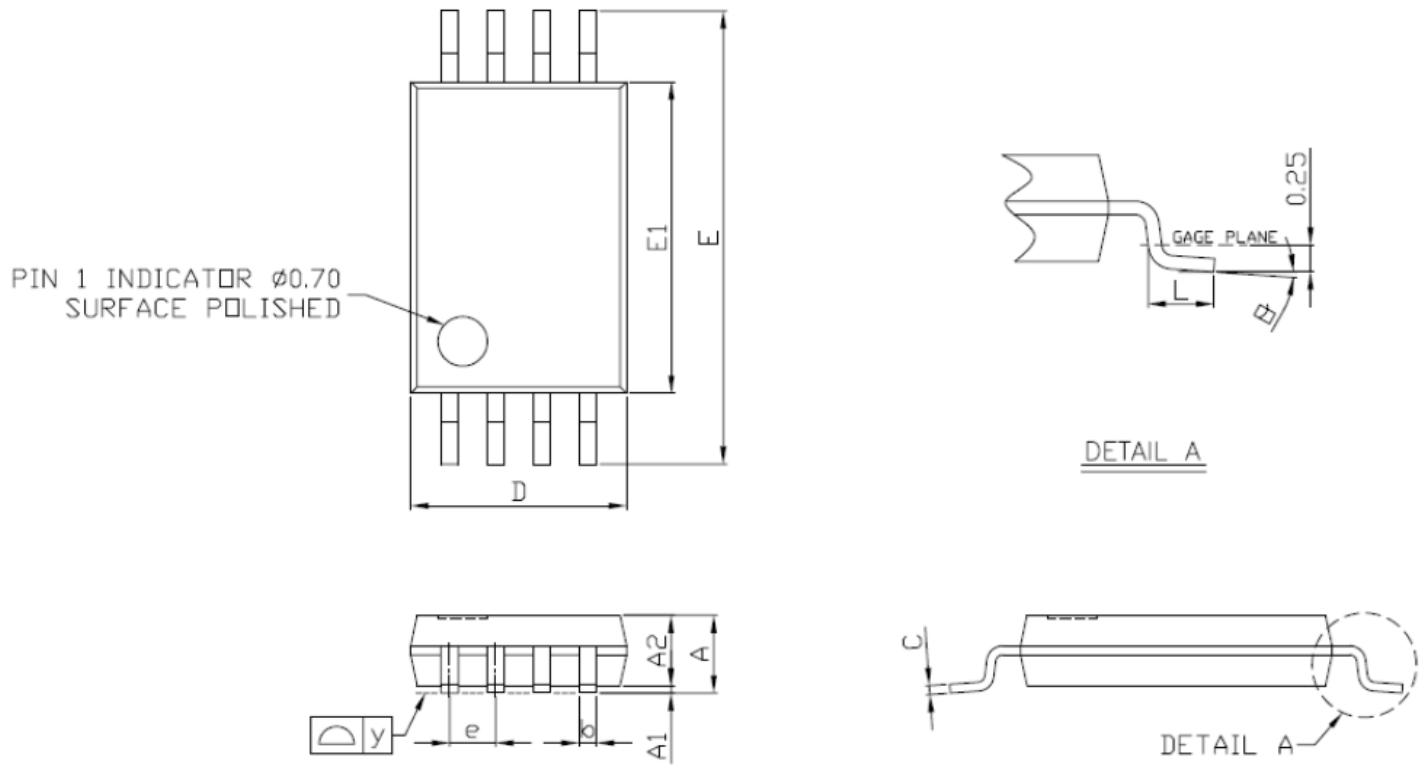

Figure 25: TSSOP-8 Package Drawing and Dimensions

Table 4: CT455 TSSOP-8 Package Dimensions

Symbol	Dimensions in Millimeters (mm)		
	Min.	Typ.	Max.
A	1.05	1.10	1.20
A1	0.05	0.10	0.15
A2	–	1.00	1.05
b	0.25	–	0.30
C	–	0.127	–
D	2.90	3.05	3.10
E	6.20	6.40	6.60
E1	4.30	4.40	4.50
e	–	0.65	–
L	0.50	0.60	0.70
y	–	–	0.076
θ	0°	4°	8°

### TAPE AND REEL POCKET DRAWINGS AND DIMENSIONS

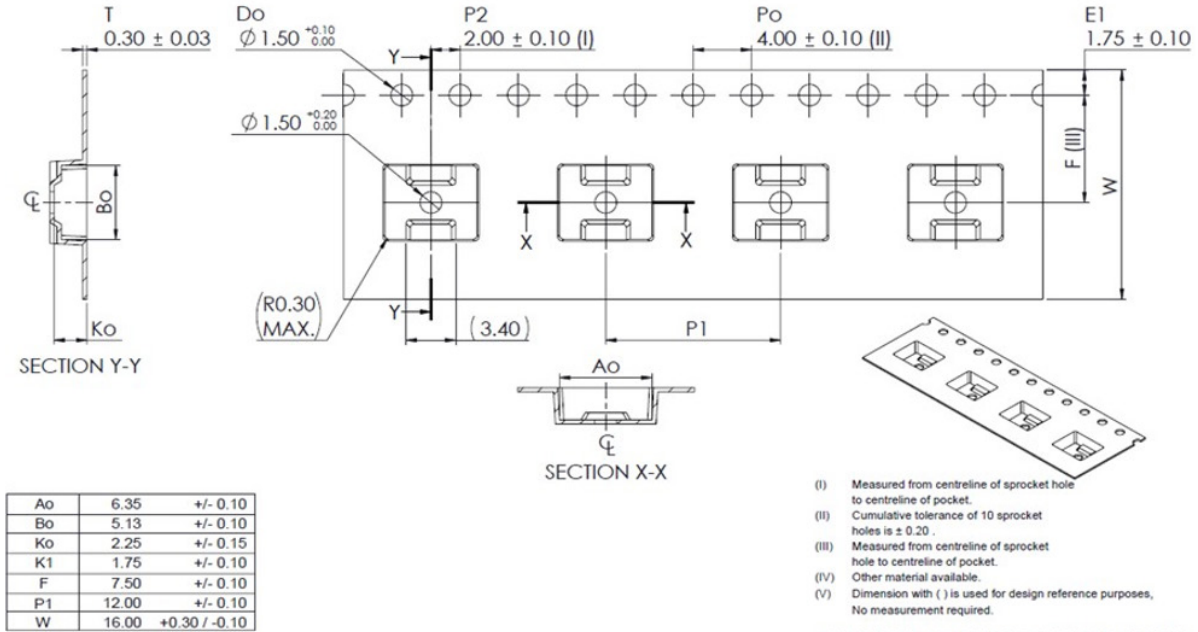

Figure 26: Tape and Pocket Drawing for SOIC-8 Package

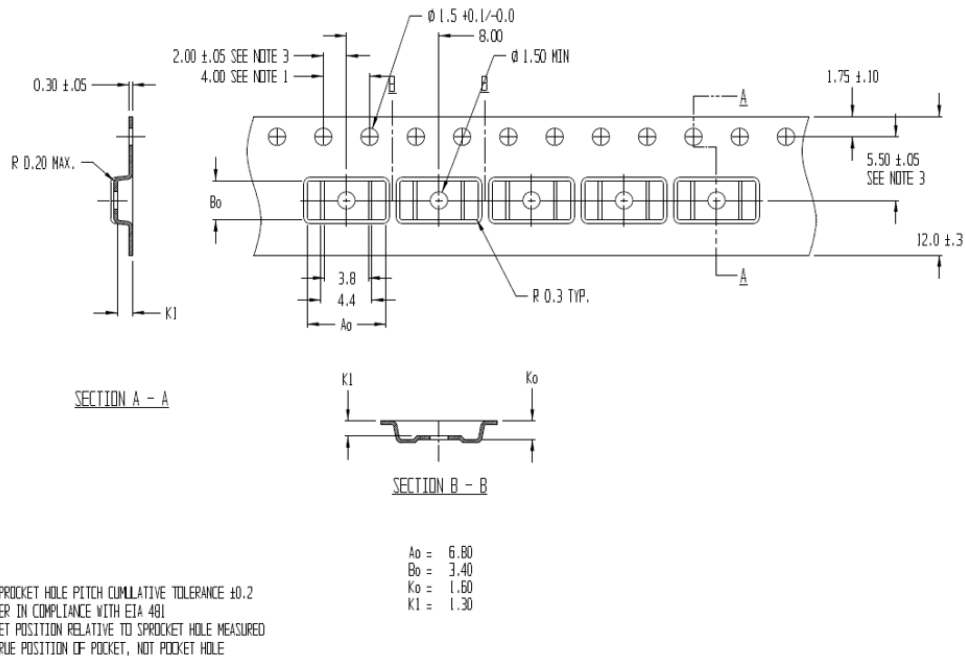

Figure 27: Tape and Pocket Drawing for TSSOP-8 Package

### DEVICE MARKINGS

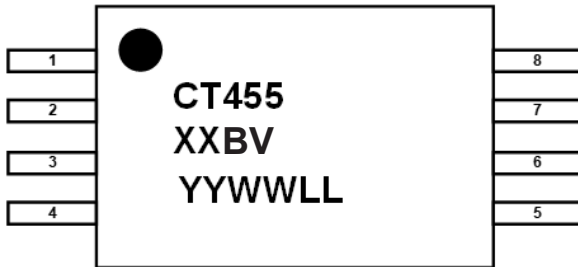

Figure 28: CT455 Device Marking for 8-Lead TSSOP Package

Table 5: CT455 Device Marking Definition for 8-lead TSSOP Package

Row No.	Code	Definition
1	•	Pin 1 Indicator
2	CT455	Allegro Part Number
2	XX	Maximum Magnetic Field Rating
2	B	Sensing Polarity
2	V	Supply Voltage
3	YY	Calendar Year
3	WW	Work Week
3	LL	Lot Code

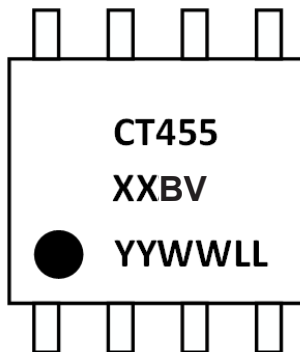
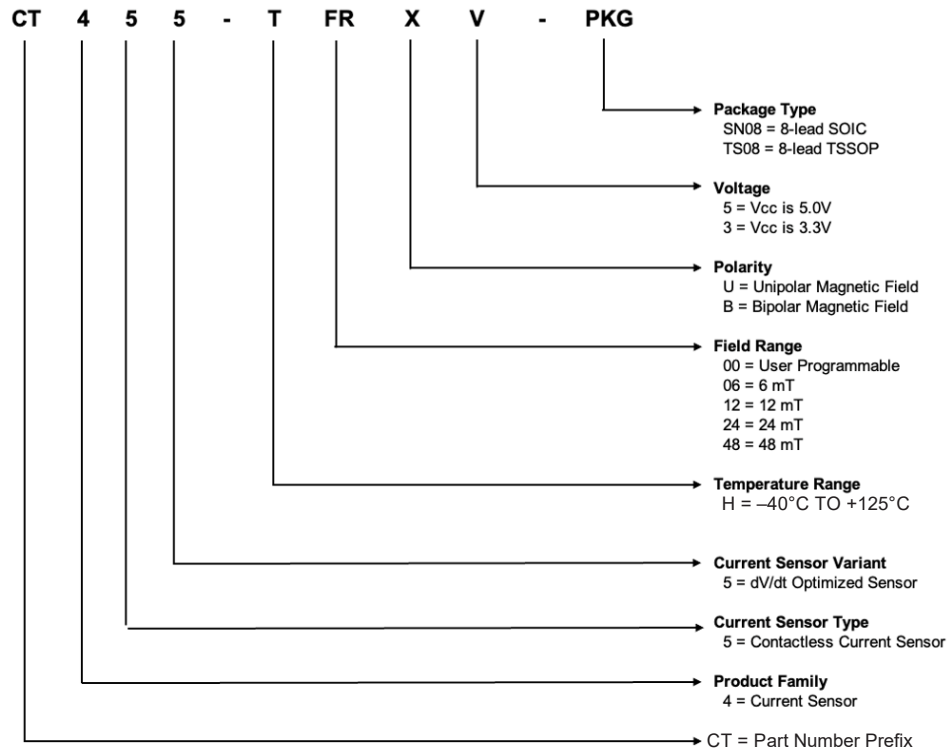

Figure 29: CT455 Device Marking for 8-Lead SOIC Package

Table 6: CT455 Device Marking Definition for 8-lead SOIC Package

Row No.	Code	Definition
3	•	Pin 1 Indicator
1	CT455	Allegro Part Number
2	XX	Maximum Field Rating
2	B	Sensing Polarity
2	V	Supply Voltage
3	YY	Calendar Year
3	WW	Work Week
3	LL	Lot Code

### PART ORDERING NUMBER LEGEND



**Revision History**

Number	Date	Description
2	November 2, 2023	Document rebranded and minor editorial updates
3	January 25, 2024	Corrected packaging column in Selection Guide table (page 3)
4	March 6, 2024	Removed AEC-Q100 (pages 1, 2, 19-20) Updated Offset Voltage (pages 8-11); removed Out Accuracy Performance (pages 8-11); updated Sensitivity and removed Noise (page 11)
5	March 20, 2024	Updated Features and Benefits (page 1), Figure 3 and 4 (page 4), Terminal Lists (page 5), and Device Markings (page 19)

Copyright 2024, Allegro MicroSystems.

Allegro MicroSystems reserves the right to make, from time to time, such departures from the detail specifications as may be required to permit improvements in the performance, reliability, or manufacturability of its products. Before placing an order, the user is cautioned to verify that the information being relied upon is current.

Allegro's products are not to be used in any devices or systems, including but not limited to life support devices or systems, in which a failure of Allegro's product can reasonably be expected to cause bodily harm.

The information included herein is believed to be accurate and reliable. However, Allegro MicroSystems assumes no responsibility for its use; nor for any infringement of patents or other rights of third parties which may result from its use.

Copies of this document are considered uncontrolled documents.

For the latest version of this document, visit our website:

[www.allegromicro.com](http://www.allegromicro.com)