

PART NAME: KNOB SCALE: 1:1 DATE: 3/28/07 DR. BY JAM

DAVIES MOLDING COMPANY
CAROL STREAM, ILLINOIS 60188

P/N 1940CJ

BASE PART 1940-03

SET SCREW I0545

PP CLICHE TF-1783

THIS DRAWING IS THE PROPERTY OF DAVIES MOLDING COMPANY, IS SUBMITTED SOLELY AS A DESIGN OR ENGINEERING PROJECT. WE ACCEPT NO RESPONSIBILITY WHATSOEVER FOR THE PRACTICAL APPLICATION OF THE PIECES MADE TO THIS DESIGN.

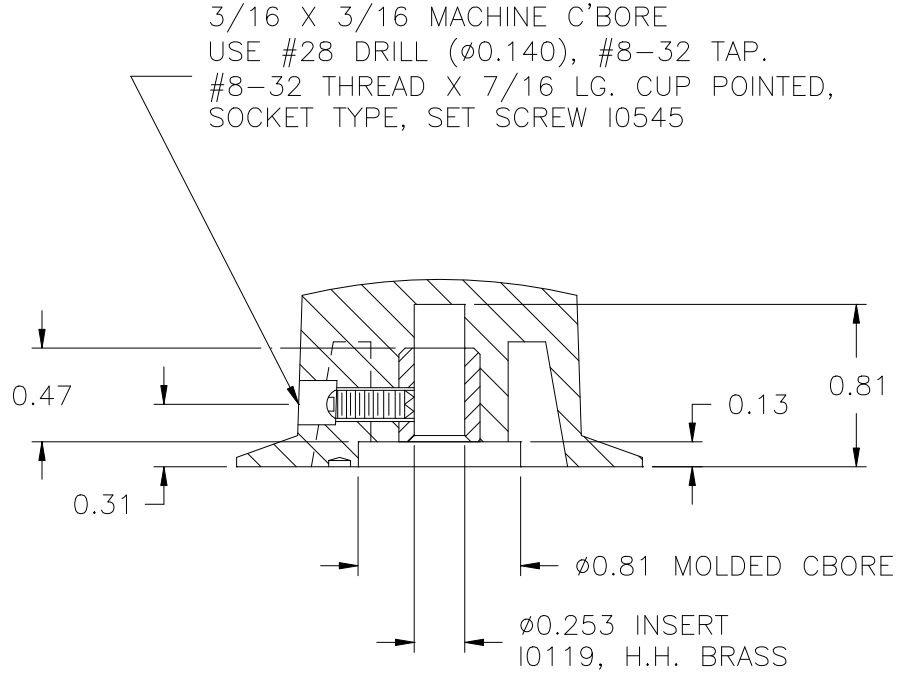
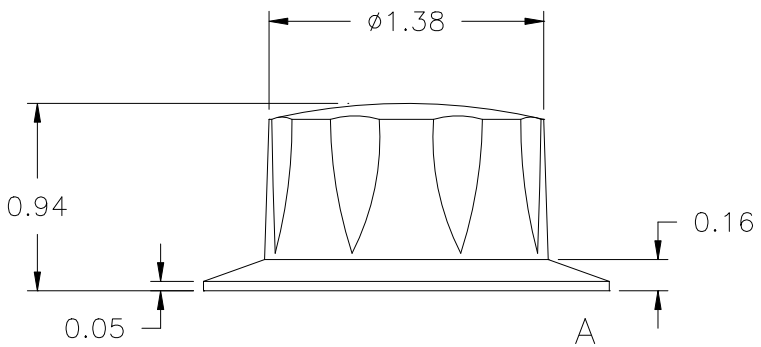
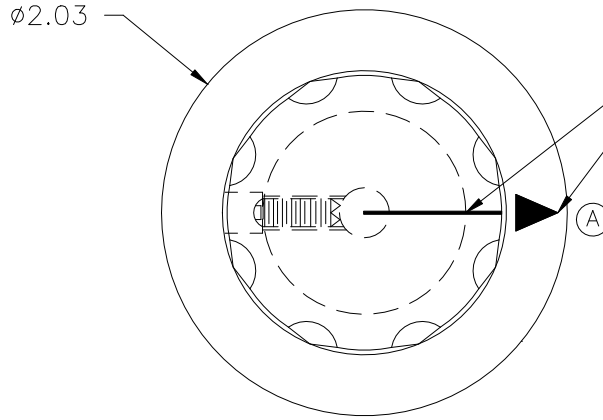

SECTION A-A

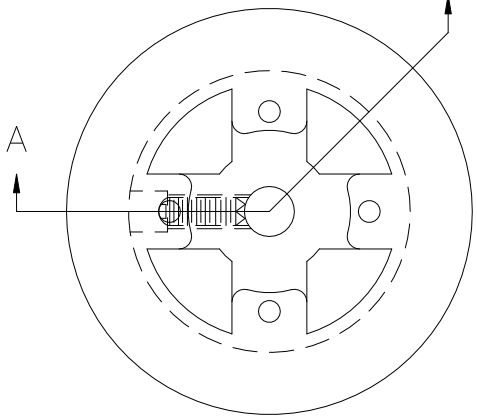

(B)
MATERIAL: 04311 PHENOLIC (B41)
COLOR: BLACK

TOLERANCES: UNLESS OTHERWISE SPECIFIED	DO NOT SCALE DRAWING	B	WAS #2511 PHENOLIC (B11)	JAM	7/16/08		
		A	ADDED ARROW	JAM	5/31/07		
DECIMALS: X.XXX $\pm .005$ X.XX $\pm .015$		MM: X.XX ± 0.15 MM X.X ± 0.4 MM		-	WAS SK1940-55	JAM	3/28/07
FRACTIONS $\pm 1/64$		ANG. $\pm 1'$		CHANGES			