



DESIGNERS & MANUFACTURERS OF KNOBS, HANDLES, CASES & CUSTOM PLASTIC COMPONENTS

P/N 1940BJ

BASE PART 1940-05

SET SCREW I0545

INLAY I0566(SS)

ⓓ

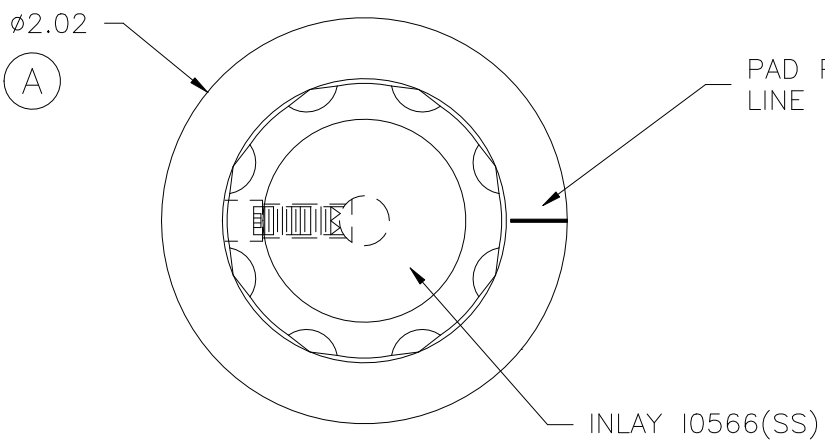

ⓑ

PACK IN EGG CRATE CONTAINERS

3/16 X 3/16 MACHINE C'BORE
 USE #28 DRILL (⌀0.140), #8-32 TAP.
 #8-32 THREAD X 7/16 LG. CUP POINTED,
 SOCKET TYPE, SET SCREW I0545

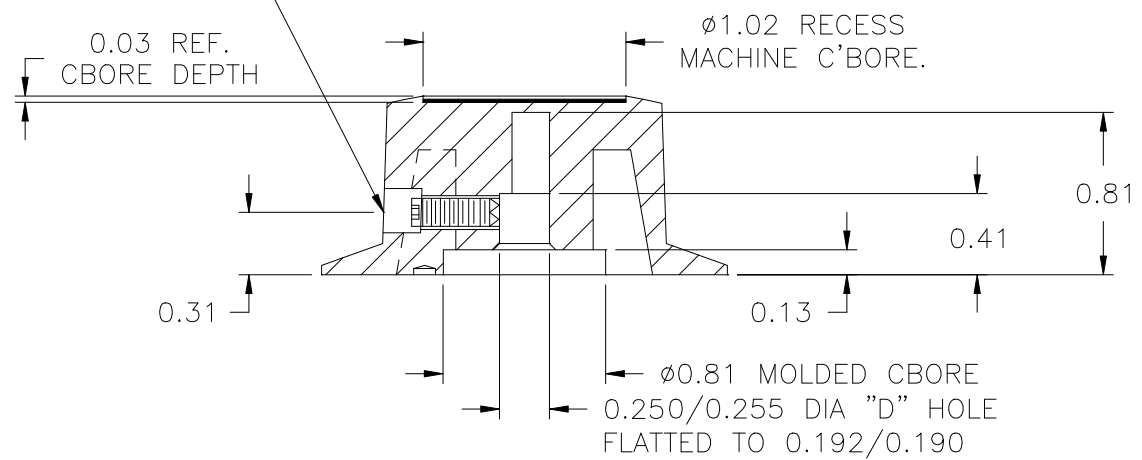

SECTION A-A

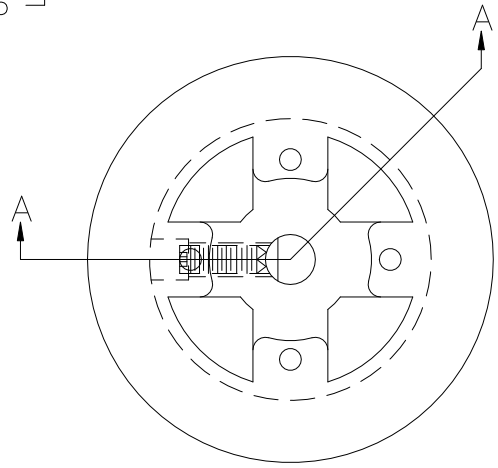

ⓒ

MATERIAL: 04311 PHENOLIC (B41)
 COLOR: BLACK

TOLERANCES: UNLESS OTHERWISE SPECIFIED	DO NOT SCALE DRAWING	D	ADDED BASE PART	JAM	4/17/14
		C	WAS #2511 PHENOLIC (B11)	JAM	7/16/08
DECIMALS: X.XXX ± .005 X.XX ± .015	MM: X.XX ± 0.15MM X.X ± 0.4MM	B	ADD PACKING INFORMATION	DD	4/7/05
		A	WAS ⌀2.00	TL	9/24/99
FRACTIONS ± 1/64	ANG. ± 1°	-	CAD/REDRAWN	HD	9/15/97
CHANGES					