

PART NAME: KNOB SCALE: 1:1 DATE: 9/12/97 DR. BY HD

DAVIES MOLDING COMPANY
CAROL STREAM, ILLINOIS 60188

P/N 1940AL

BASE PART	1940-01
INLAY	I0566(SS)
SET SCREW	I0022

THIS DRAWING IS THE PROPERTY OF DAVIES MOLDING COMPANY, IS SUBMITTED SOLELY AS A DESIGN OR ENGINEERING PROJECT. WE ACCEPT NO RESPONSIBILITY WHATSOEVER FOR THE PRACTICAL APPLICATION OF THE PIECES MADE TO THIS DESIGN.

⌀2.00
A

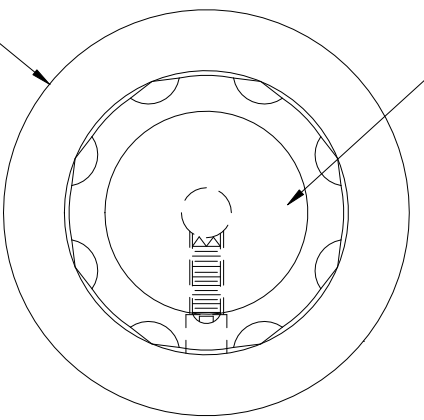

INLAY I0566(SS)
(SPUN-SILVER, ALUMINUM)

$\frac{3}{16} \times \frac{3}{16}$ MACHINE C'BORE
USE #28 DRILL (⌀0.140), #8-32 TAP.
#8-32 THREAD X 7/16 LG. CUP POINTED,
SLOTTED TYPE, SET SCREW I0022.

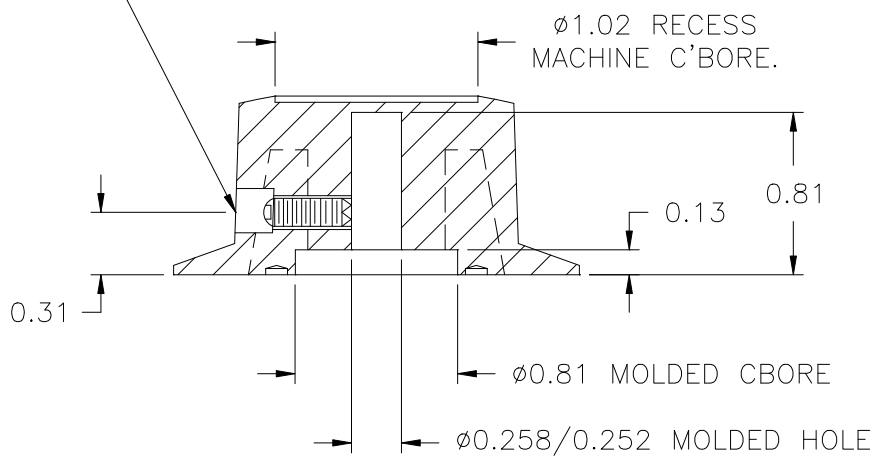
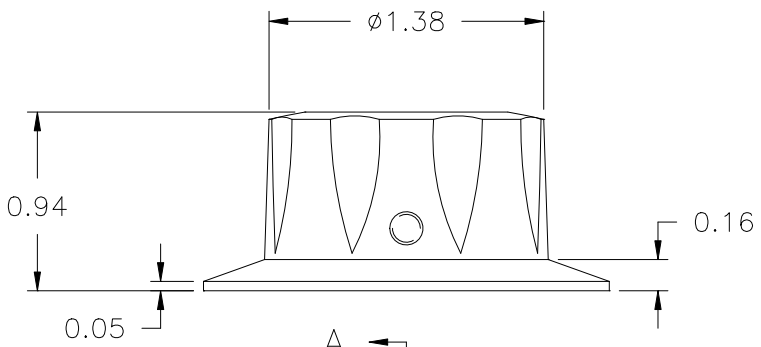

SECTION A-A

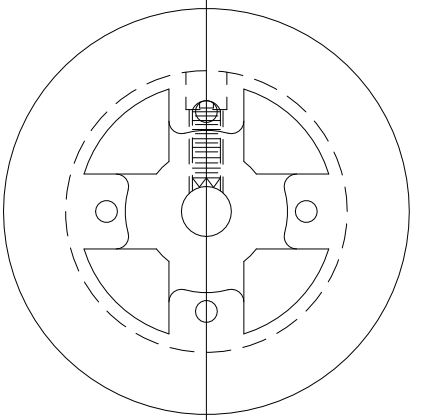

ⓑ MATERIAL: 04311 PHENOLIC (B41)
COLOR: BLACK

TOLERANCES: UNLESS OTHERWISE SPECIFIED	DO NOT SCALE DRAWING	B	WAS #2511 PHENOLIC (B11)	JAM	7/16/08
DECIMALS: X.XXX ± .005 X.XX ± .015	MM: X.XX ± 0.15MM X.X ± 0.4MM	-	UPDATED/HAD TOOLBOX	ST	11/20/2000
FRACTIONS ± 1/64	ANG. ± 1'	A	WAS ⌀2.00	TL	24/9/99
CHANGES					