

DRW NO. C-800-1453-500 SH 1 REV A

ZONE	REV	ECN	DESCRIPTION	BY	DATE	APPROVED
ALL	A	BW AG-17110301	NEW RELEASE	HCL-SA	11/13/2017	B.W ANG

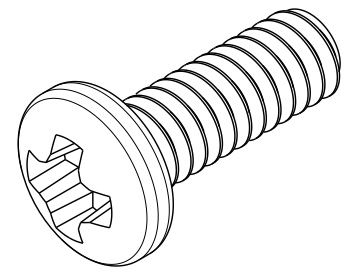

ISOMETRIC VIEW
SCALE 6/1

TABLE 1		
PART NUMBER	MAGNETIC / NON MAGNETIC	L
800-1453-000	NON MAGNETIC	0.219 ^{+0.000} / _{-0.02}

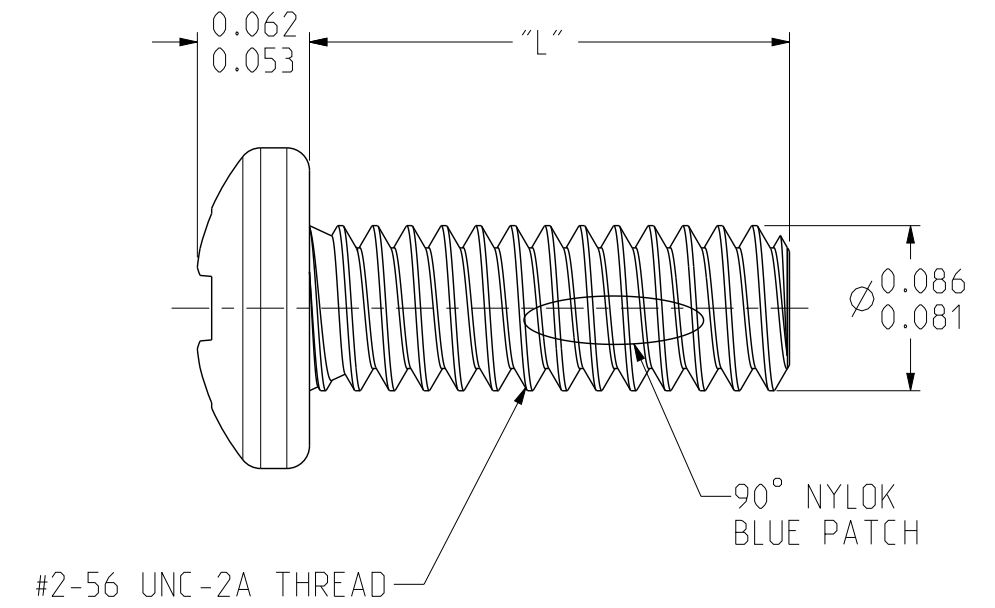
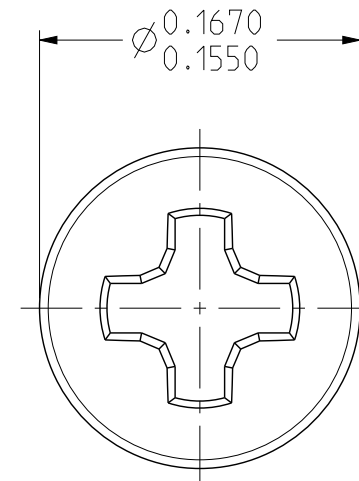

TOLERANCES	DESIGN
0.0 ± -	08/12/2008 C.SAMMIS
0.00 ± -	DRAWN 11/13/2017 HCL-SA
0.000 ± -	CHK 11/13/2017 B.W ANG
ANGLES ± -	APVD 11/13/2017 B.W ANG

Amphenol TCS A Division of Amphenol Corporation 200 Innovative Way, Nashua, NH 03062 603.879.3000	
TITLE SCREW PAN HEAD PHILLIPS, #2-56 W NYLOK	
PART NO.	SEE TABLE 1
DRAWING NO.	C-800-1453-500
REV	N/A
REV	A
PART FILE	800-1453-500
DRAWING FILE	C-800-1453-500
REV	0.0
REV	0.1
SIZE	B
SCALE	10/1
SHEET 1 OF 1	

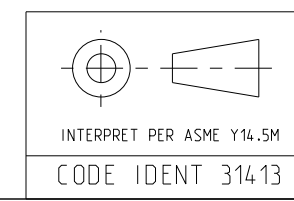

UNLESS OTHERWISE SPECIFIED DIMENSIONS ARE IN INCHES
CUSTOMER USE DRAWING

NOTES:
1. MATERIAL : 300 SERIES SS

DRW NO. C-800-1453-500 SH 1 REV A