

REFERENCE SPECIFICATIONS

-NFC 93425 (in compliance with HE 507)

PHYSICAL CHARACTERISTICS

- INSULATOR MATERIAL: THERMOPLASTIC UL94V0
- CONTACT MATERIAL: PHOSPHOR BRONZE( SIGNAL CONTACT )  
BRASS (POWERS CONTACT)
- ACCESSORIES: BRASS
- SHELLS: STEEL

ELECTRICAL CHARACTERISTICS

- NOMINAL CURRENT: 7.5A (SIGNAL CONTACT)  
30A or 40A (POWER CONTACT)
- CONTACT RESISTANCE: 7.3 m Ohms(SIGNAL and POWER)
- CONTACT/CONTACT : 1000 V
- CONTACT/GROUND : 1200 V
- INSULATION RESISTANCE: 5000 MOhms

ENVIRONEMENTAL CHARACTERISTICS

- CLIMATIC CATEGORY: 55/125/21  
TEMPERATURE RANGE -55°C TO +125°C  
DAMP HEAT STEADY STATE 21 DAYS  
SALT SPRAY 24 HOURS

MECHANICAL CHARACTERISTICS

- RETENTION AGAINST TORQUE: - Threaded insert: 0.7 N.m Maximum  
- Female screw : 0.5 N.m Maximum

NOTE RoHS INFORMATION

- The "LF" products meet european union Directives and other country regulations as described in GS-47-0004.
- The housing will withstand exposure to 260°C peak temperature for 3.5 seconds in a wave solder application with a 1.6mm minimum thick circuit board. See application notes/procedures if they are available.
- Termination plating spec:
  - Signal contacts: Ni + Gold/GxT
  - Power contacts: Ni 1.27µmi+Sn 2.5 to 7.5µ,pure bright
- Active area plating spec:
  - Signal and power contacts: Ni + Gold/GxT
- Shell plating :2 to 4µm Cu + 3 to 10µmm Sn,pure bright
- Accessories: Sn pure bright
- Packaging spec: See GS-14-920

# DBL13W3S300G30LF

Series

Shell size: **E A B C D**  
see sheet 3

Front accessory definition  
see sheet 2

- L** : threaded insert M3
- O** : threaded insert UNC 4-40
- V** : female screw UNC 4-40

Layout of contacts (see sheet 3)

Contacts

- S** : Socket

Termination type

- 3** Straight version

Plating

- 00** 200 matings/unmatings
- 43** 500 matings/unmatings

PCB accessories definition  
see sheet 2

- H** : harpoons for PCB 2.40mm
- G** : harpoons for PCB 1.60mm

Power contacts

- 30** : Fitted with power contacts 30 Amp.
- 40** : Fitted with power contacts 40 Amp.

See note RoHS

TABLE 1:PCB HOLE DIAMETERS

	POWER CONTACTS		ACCESSORIES	SIGNAL CONTACTS
30 A	2.00	ø2.40	ø3.10	ø1.00
40 A	2.80	3.10		
Max current power	Ø A ±0.1	PCB HOLE +/-0.1	PCB HOLE +/-0.1	PCB HOLE +/-0.1

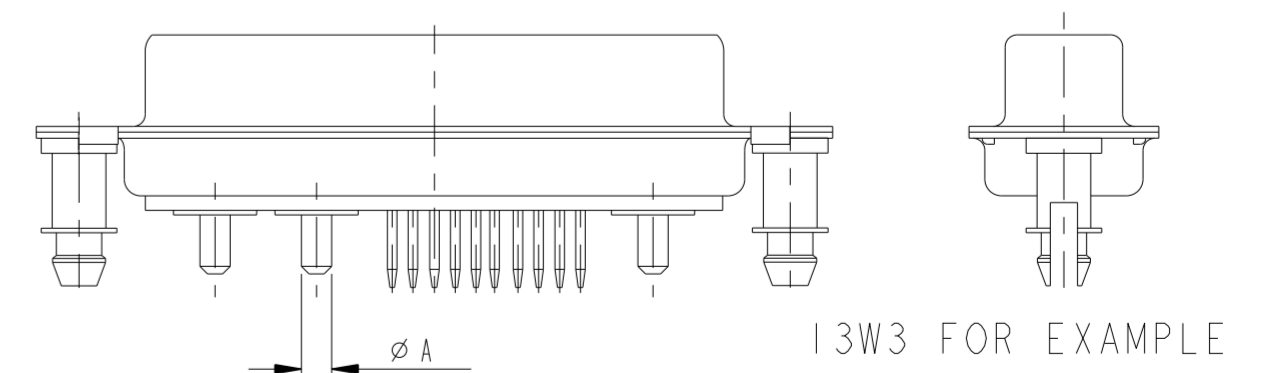

spec ref	dr	1, Product Eng	2015/06/12	projection	MM	size	A2	scale	1:1
tolerance std	eng	Gregar Mathew	2019/11/11			ecn no	ELX-32909-1	rel level	Released
ISO 406 ISO 1101	chr	-	appr						
surface	linear	0.X ±0.3 0.XX ±0.1 0.XXX ±0.05			title SUB FEMALE DW MIXED POWER STRAIGHT SOLDER		cat. no. C01-8639-2302c	rev K	sheet 1 of 7
ISO 1302	angular	0° ±22°	PDS: Rev :K		STATUS:Released		Printed: Nov 12, 2019		

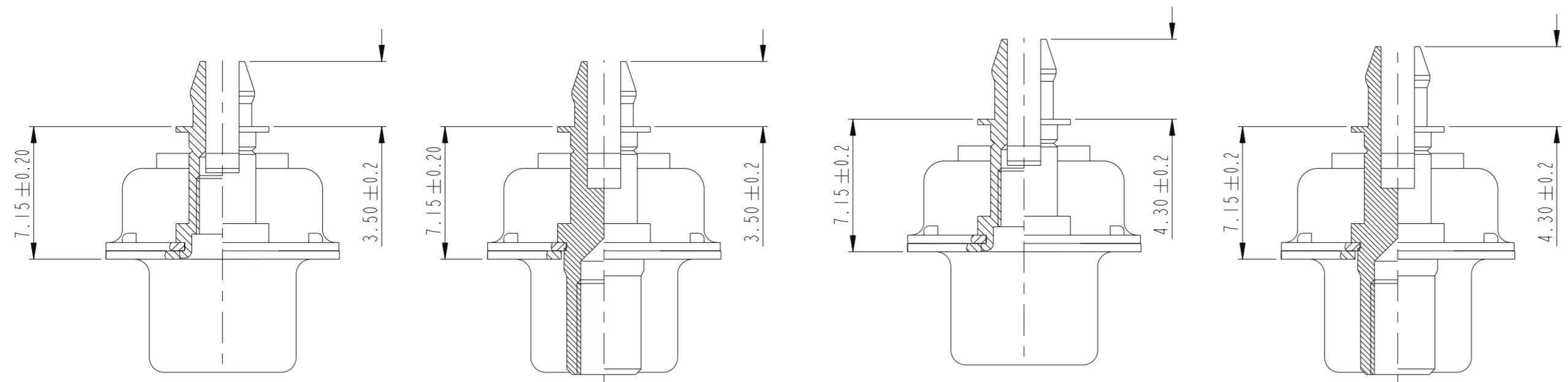

FRONT ACCESSORY	<b>L</b> insert M3 <b>O</b> insert UNC 4.40	<b>V</b> insert UNC 4.40	<b>L</b> insert M3 <b>O</b> insert UNC 4.40	<b>V</b> insert UNC 4.40
PCB ACCESSORIES	<b>G</b> Harpoon for PCB 1.60mm	<b>G</b> Harpoon for PCB 1.60mm	<b>H</b> Harpoon for PCB 2.40mm	<b>H</b> Harpoon for PCB 2.40mm

PART NUMBER	AMPS	MATINGS/ UNMATINGS	FRONT ACCESSORY	PCB ACCESSORIES
D*LxWxS300G30LF	30	200	insert M3	harpoon PCB 1.60mm
D*OxWxS300G30LF	30	200	insert UNC 4.40	harpoon PCB 1.60mm
D*VxWxS300G30LF	30	200	female screw UNC 4.40	harpoon PCB 1.60mm
D*LxWxS300H30LF	30	200	insert M3	harpoon PCB 2.40mm
D*OxWxS300H30LF	30	200	insert UNC 4.40	harpoon PCB 2.40mm
D*VxWxS300H30LF	30	200	female screw UNC 4.40	harpoon PCB 2.40mm
D*LxWxS300G40LF	40	200	insert M3	harpoon PCB 1.60mm
D*OxWxS300G40LF	40	200	insert UNC 4.40	harpoon PCB 1.60mm
D*VxWxS300G40LF	40	200	female screw UNC 4.40	harpoon PCB 1.60mm
D*LxWxS300H40LF	40	200	insert M3	harpoon PCB 2.40mm
D*OxWxS300H40LF	40	200	insert UNC 4.40	harpoon PCB 2.40mm
D*VxWxS300H40LF	40	200	female screw UNC 4.40	harpoon PCB 2.40mm

shell size	LAYOUTS
*	xWx
E	5W1
A	11W1
A	7W2
B	21W1
B	17W2
B	13W3
B	9W4
C	25W3
C	21WA4
C	27W2
D	47W1
D	24W7
D	36W4

PART NUMBER	AMPS	MATINGS/ UNMATINGS	FRONT ACCESSORY	PCB ACCESSORIES
D*LxWxS343G30LF	30	500	insert M3	harpoon PCB 1.60mm
D*OxWxS343G30LF	30	500	insert UNC 4.40	harpoon PCB 1.60mm
D*VxWxS343G30LF	30	500	female screw UNC 4.40	harpoon PCB 1.60mm
D*LxWxS343H30LF	30	500	insert M3	harpoon PCB 2.40mm
D*OxWxS343H30LF	30	500	insert UNC 4.40	harpoon PCB 2.40mm
D*VxWxS343H30LF	30	500	female screw UNC 4.40	harpoon PCB 2.40mm
D*LxWxS343G40LF	40	500	insert M3	harpoon PCB 1.60mm
D*OxWxS343G40LF	40	500	insert UNC 4.40	harpoon PCB 1.60mm
D*VxWxS343G40LF	40	500	female screw UNC 4.40	harpoon PCB 1.60mm
D*LxWxS343H40LF	40	500	insert M3	harpoon PCB 2.40mm
D*OxWxS343H40LF	40	500	insert UNC 4.40	harpoon PCB 2.40mm
D*VxWxS343H40LF	40	500	female screw UNC 4.40	harpoon PCB 2.40mm

Amphenol FCI

© 2016 AFCI

spec ref	dr 1, Product Eng	2015/06/12	projection	MM	size A2	scale 3:1
tolerance std	eng Gregar Mathew	2019/11/11			ecn no ELX-32909-1	rel level Released
ISO 406 ISO 1101	chr -	-				
TOLERANCES UNLESS OTHERWISE SPECIFIED	appr Varma Sudhir	2019/11/12	<b>Amphenol FCI</b>		title SUB FEMALE DW MIXED POWER STRAIGHT SOLDER	rev K
surface	linear	0.X ±0.30 0.XX ±0.10 0.XXX ±0.05	cat. no.		C01-8639-2302c	sheet 2 of 7
ISO 1302	angular	0° ±2°	Product - Customer Drw			

PDS: Rev :K

STATUS:Released

Printed: Nov 12, 2019

5W1

LAYOUT AND CONNECTOR DIMENSIONS

For PCB hole diameters see table I sheet 1

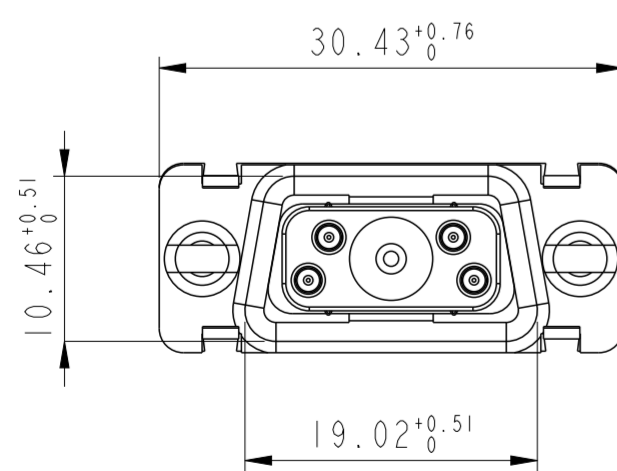
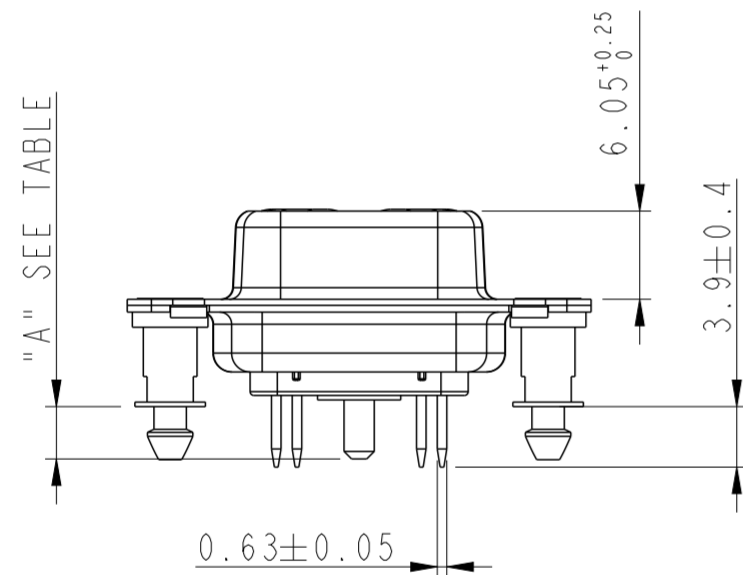
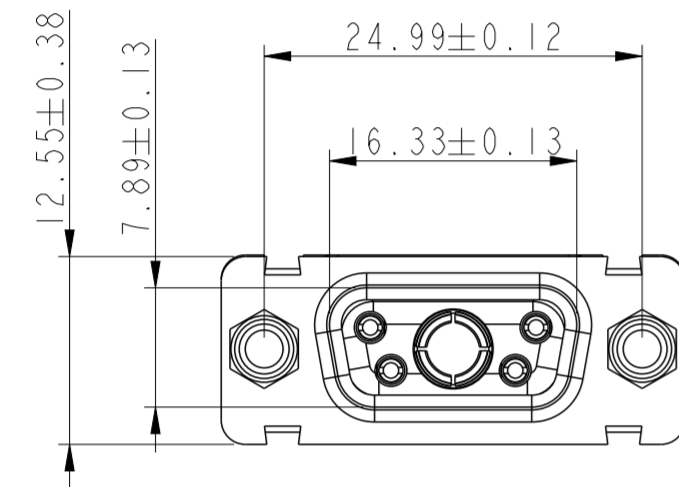
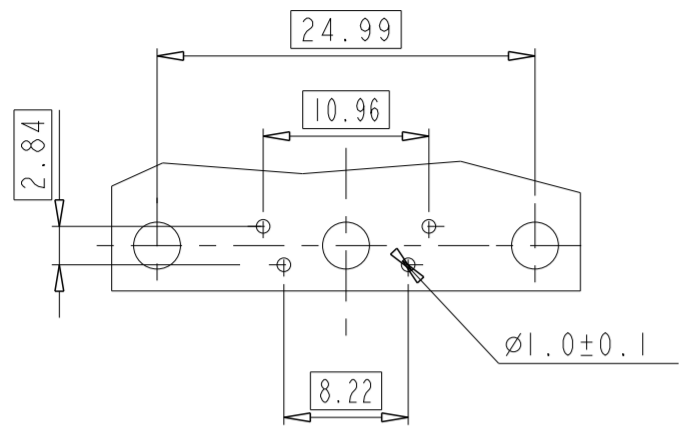

Floating signal contacts

11W1

LAYOUT AND CONNECTOR DIMENSIONS

For PCB hole diameters see table I sheet 1

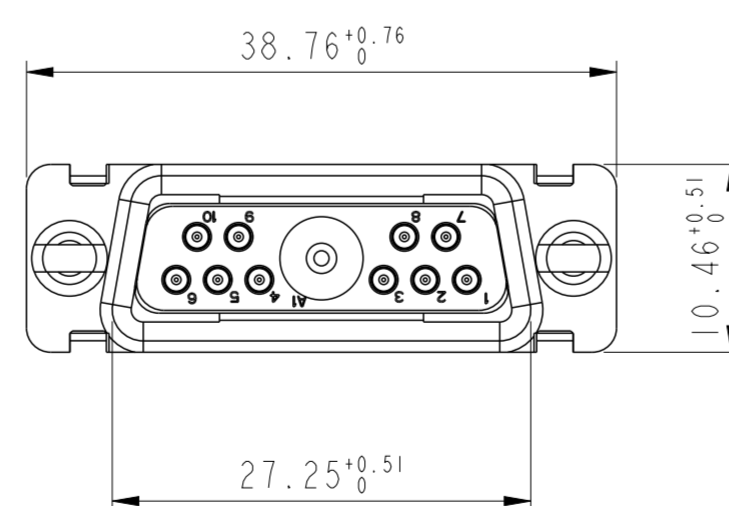
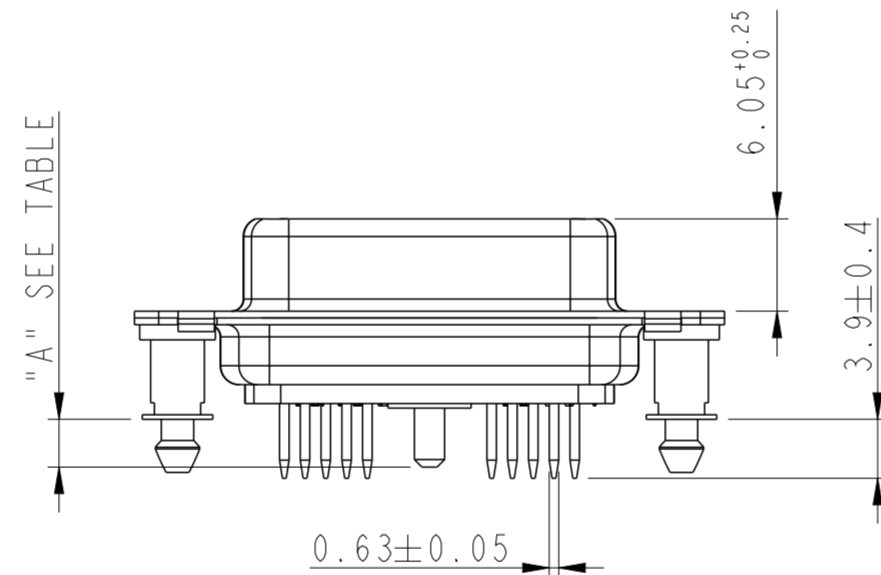
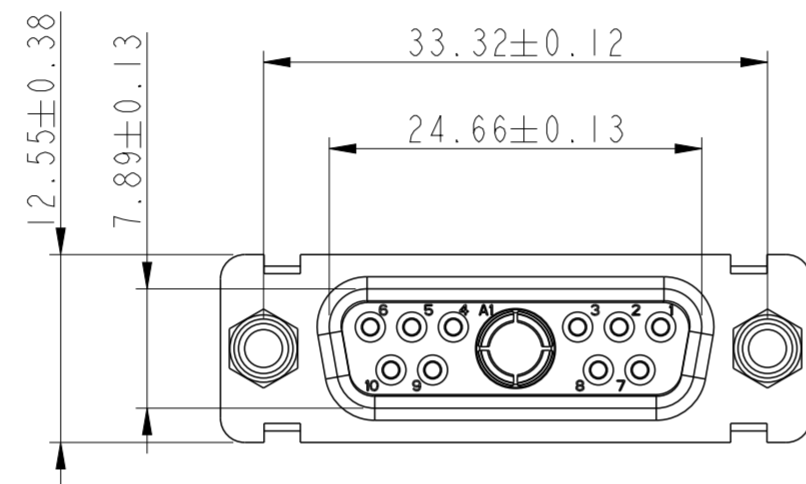
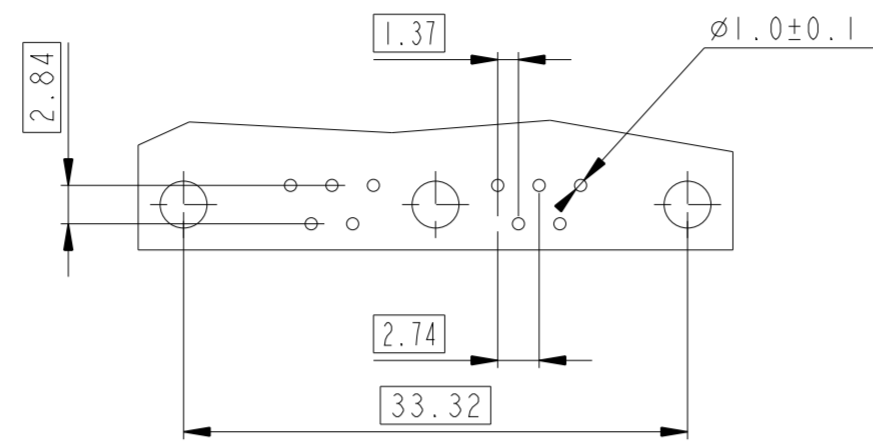

7W2

LAYOUT AND CONNECTOR DIMENSIONS

For PCB hole diameters see table I sheet 1

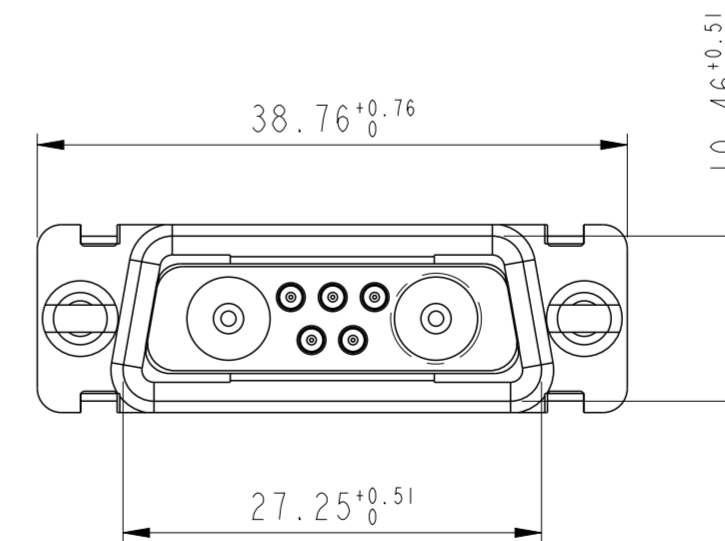
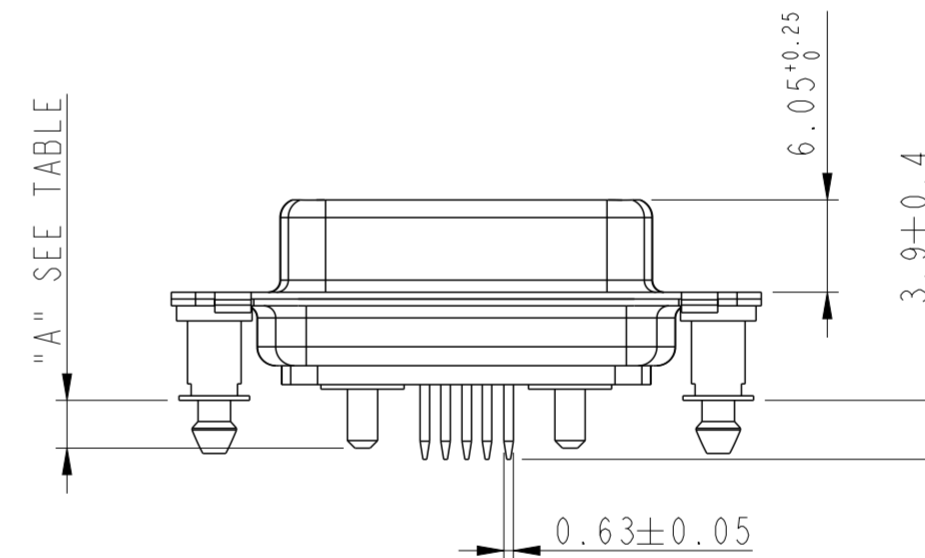
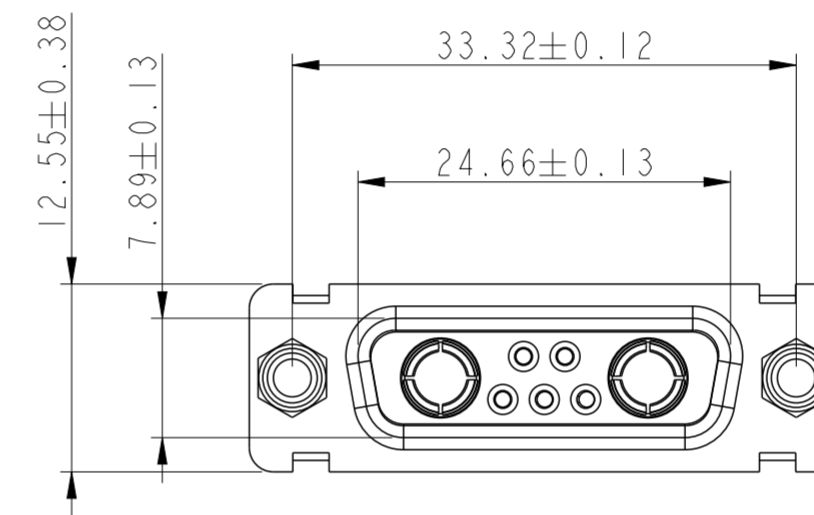
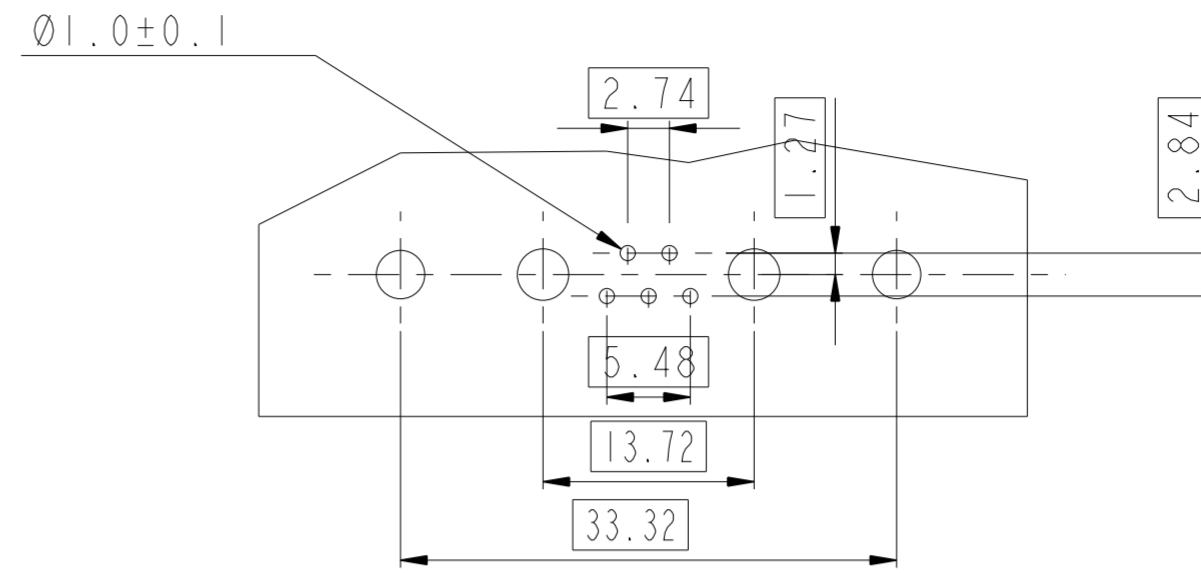

SIDE VIEW FOR LAYOUTS: E A B C

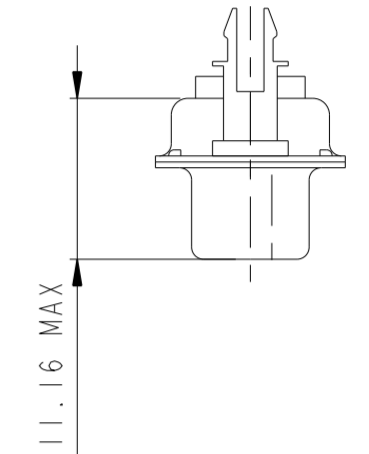

COTE "A"

30A	3.6±0.35
40A	4.0±0.35

spec ref	dr	1, Product Eng	2015/06/12	projection	MM	size	A2	scale	2:1
tolerance std	eng	Gregar Mathew	2019/11/11			D SUB	rel level	ELX-32909-1	rev
ISO 406	chr	-	product family						
ISO 1101	appr	Varma Sudhir	2019/11/12	<b>Amphenol FCI</b>		SUB FEMALE DW MIXED POWER STRAIGHT SOLDER		C01-8639-2302c	K
surface	linear	TOLERANCES UNLESS OTHERWISE SPECIFIED 0.X ±0.30 0.XX ±0.10 0.XXX ±0.05		cat. no.	Product - Customer Drw		sheet 3 of 7		
ISO 1302	angular	0° ±2°		PDS: Rev :K		STATUS:Released		Printed: Nov 12, 2019	

13W3

LAYOUT AND CONNECTOR DIMENSIONS  
For PCB hole diameters see table I sheet 1

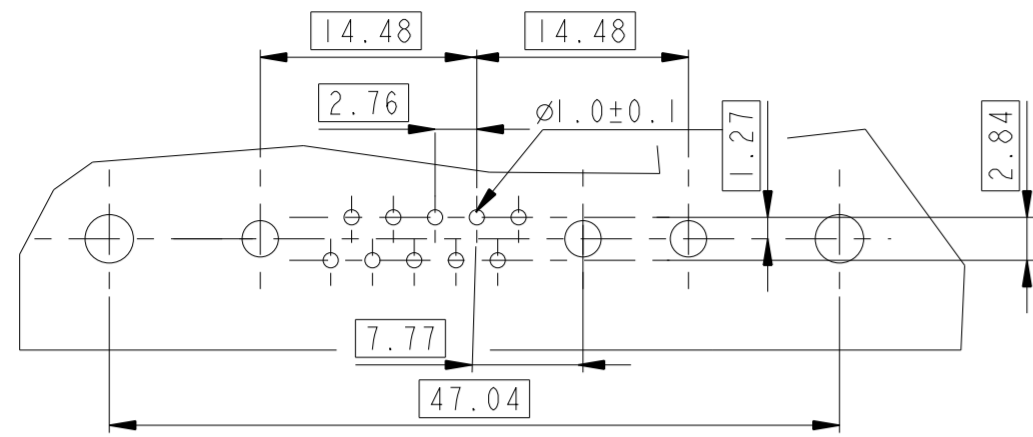

9W4

LAYOUT AND CONNECTOR DIMENSIONS  
For PCB hole diameters see table I sheet 1

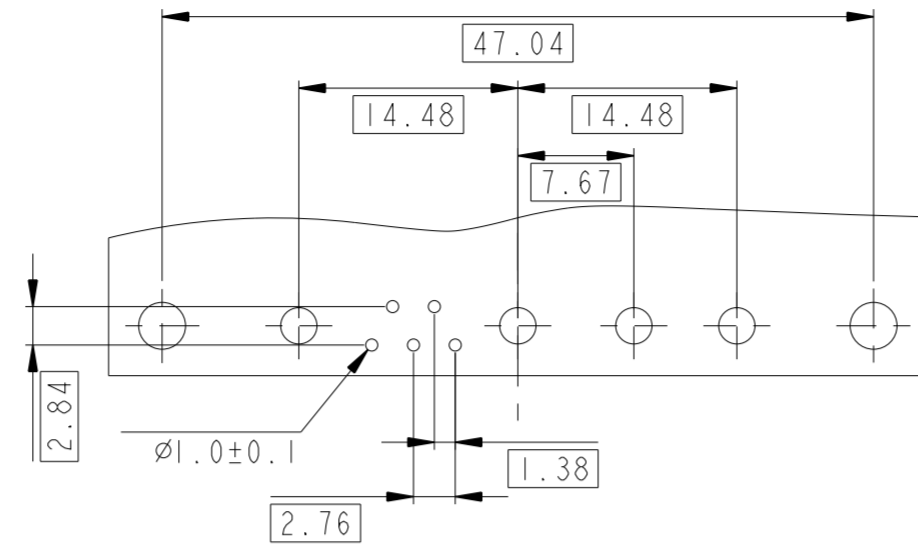

17W2

LAYOUT AND CONNECTOR DIMENSIONS  
For PCB hole diameters see table I sheet 1

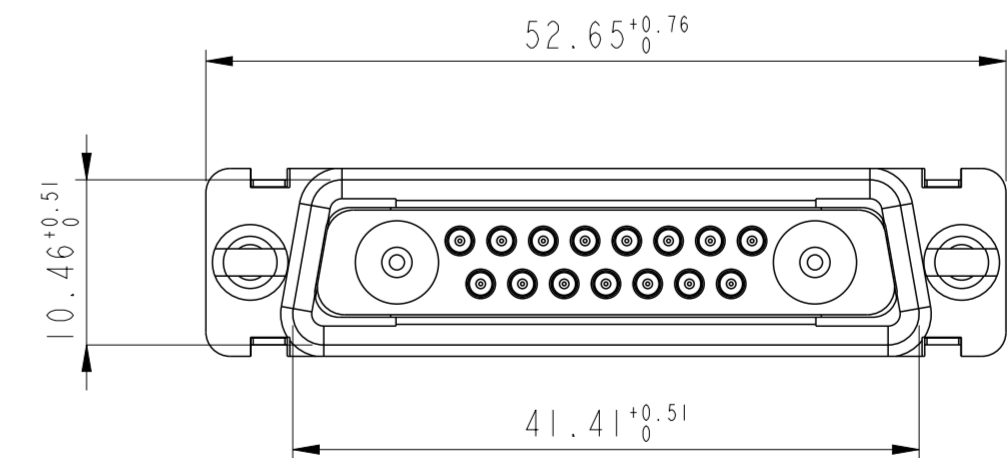
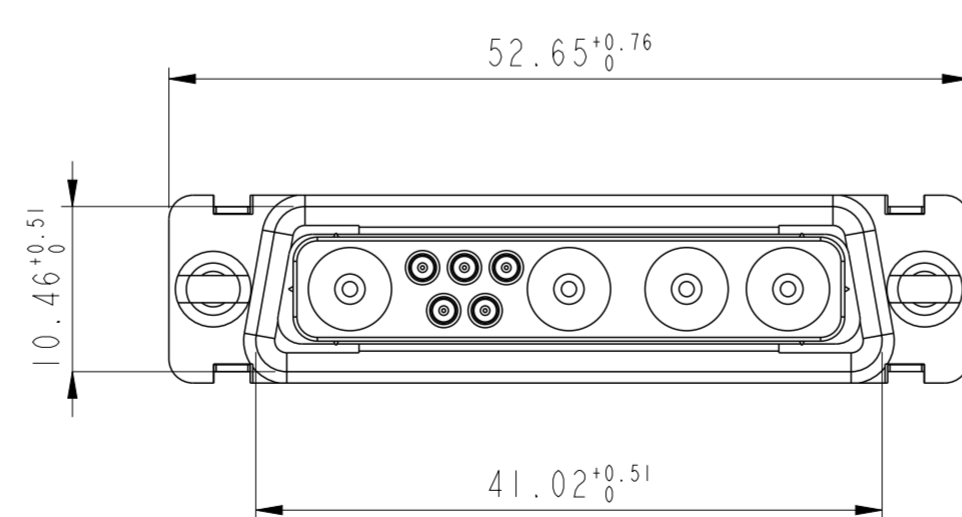
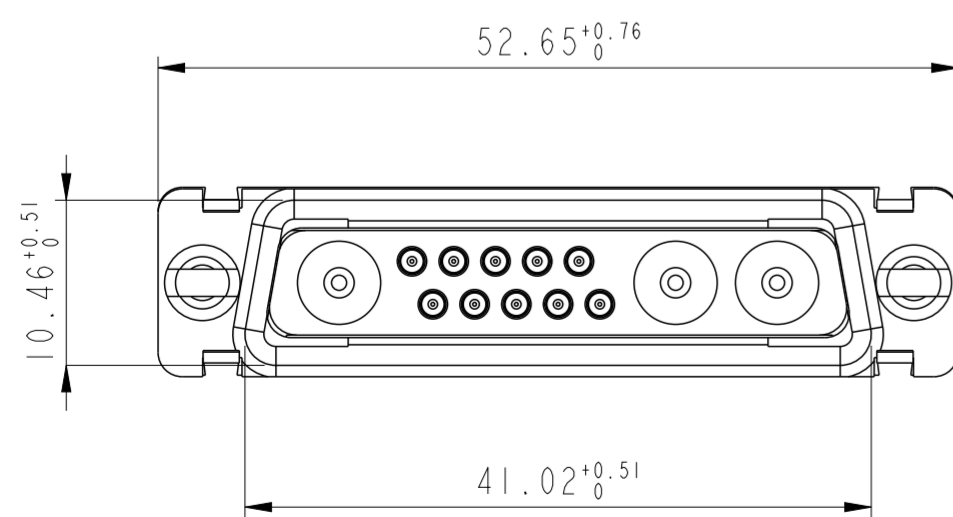
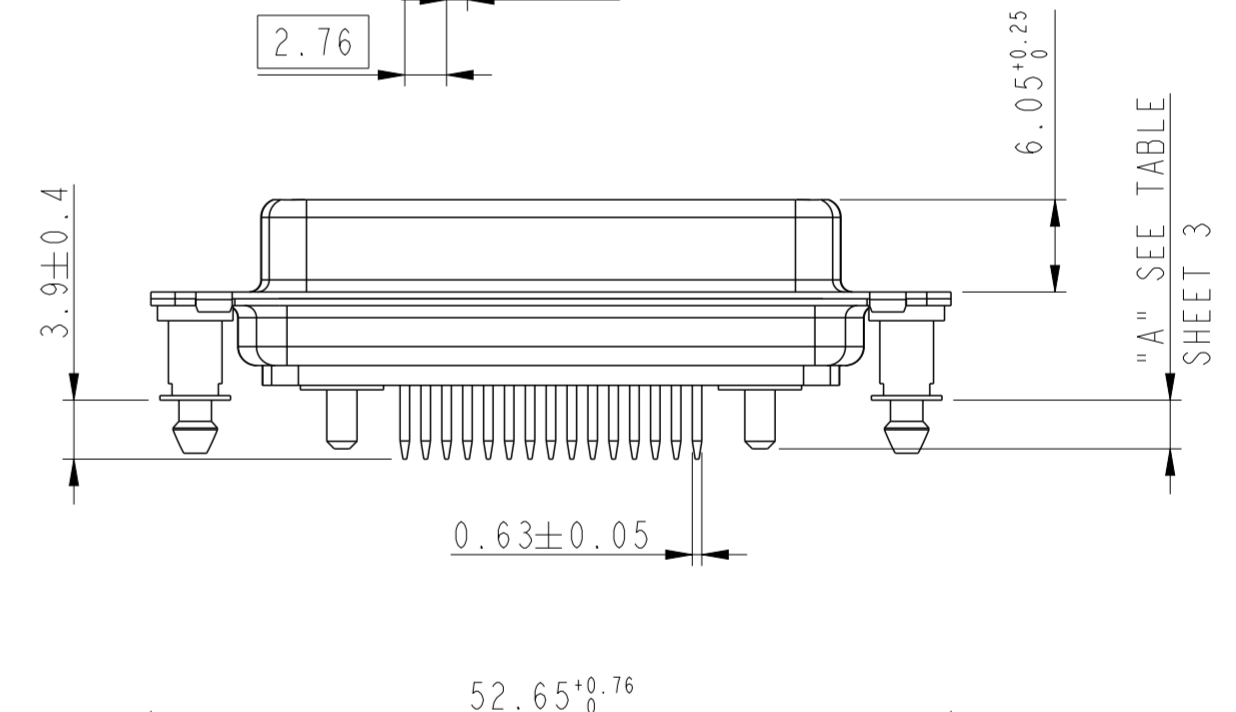
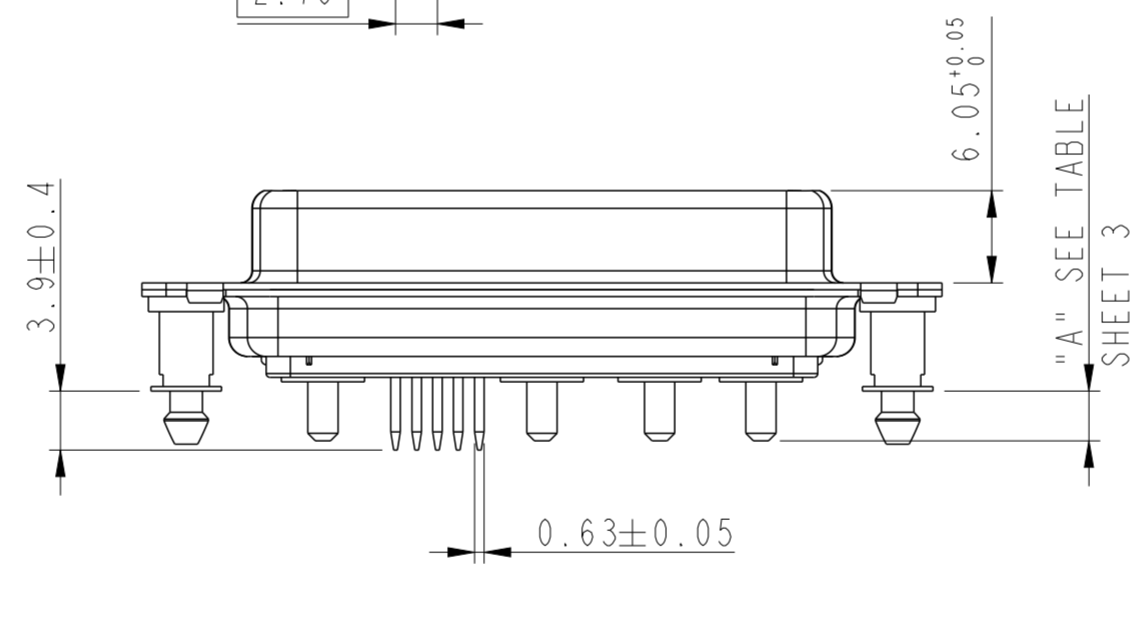
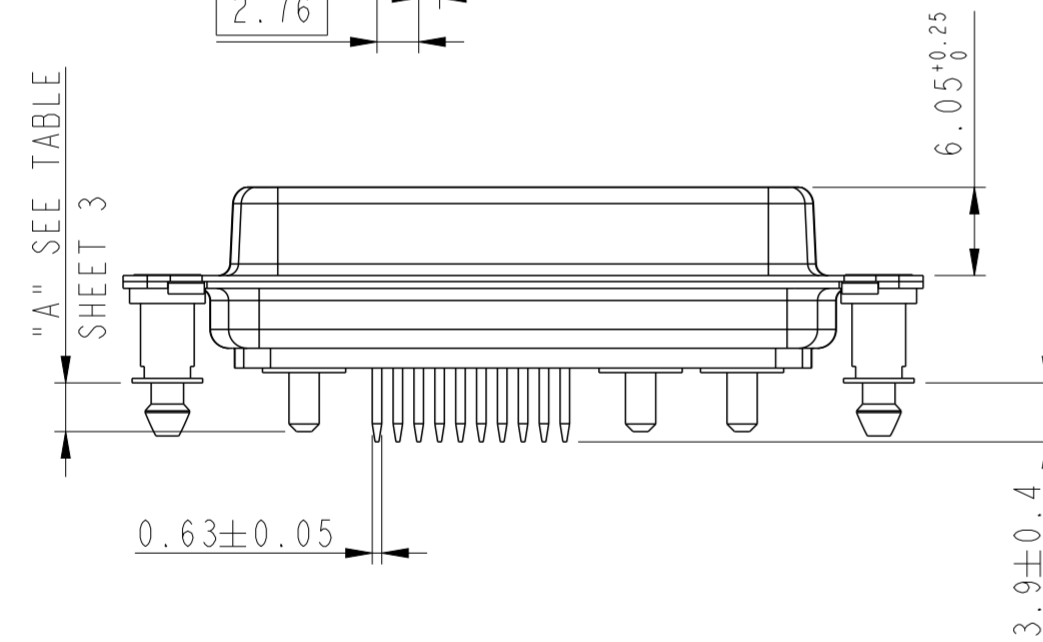
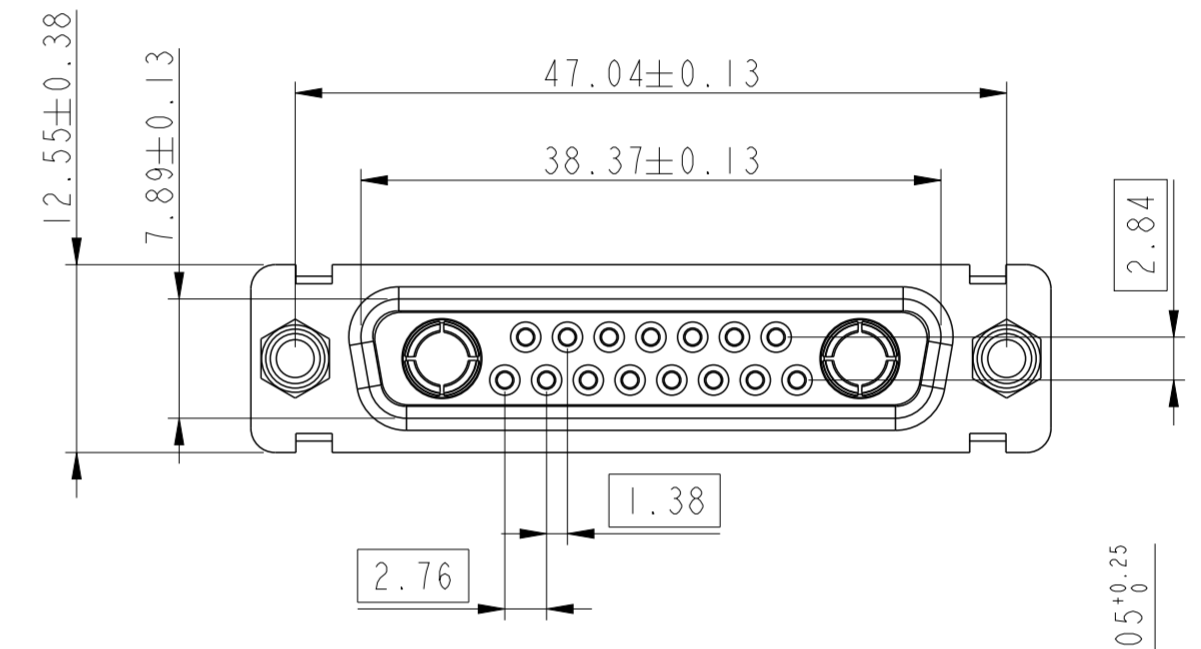
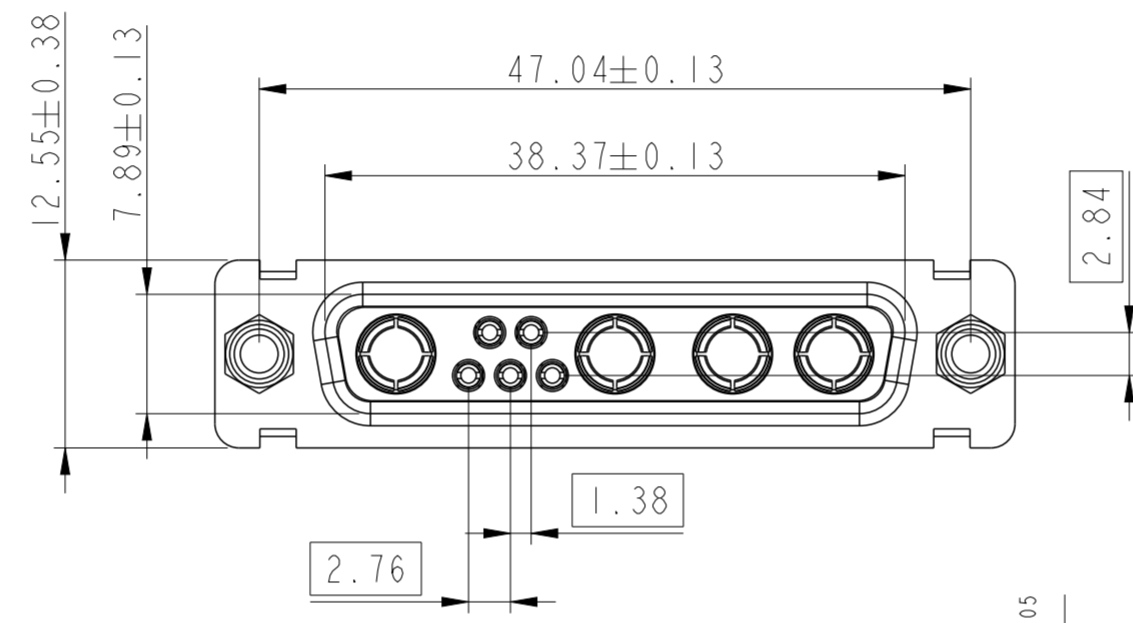
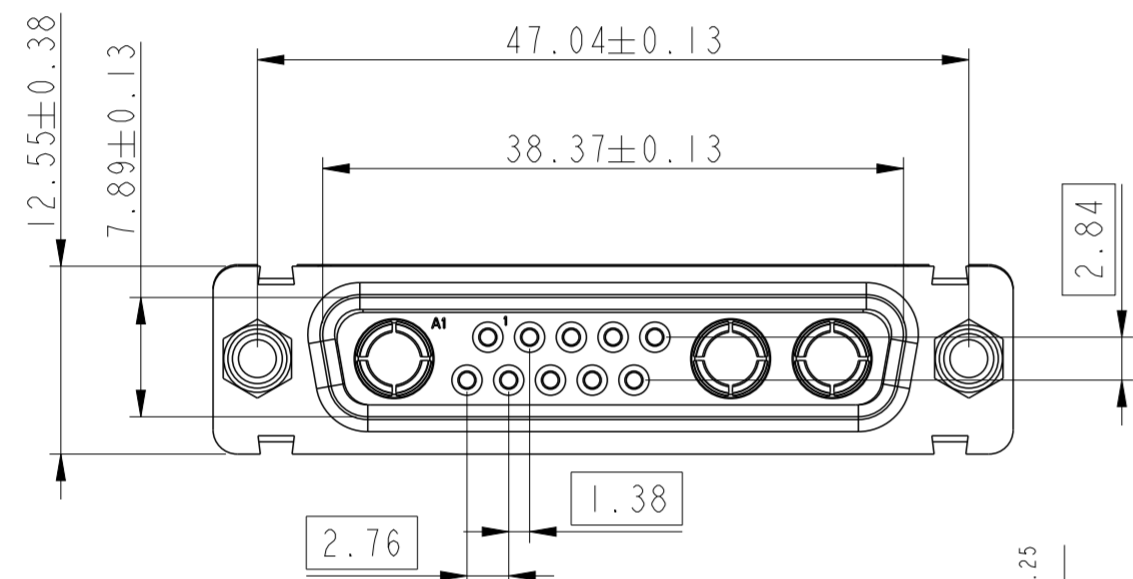
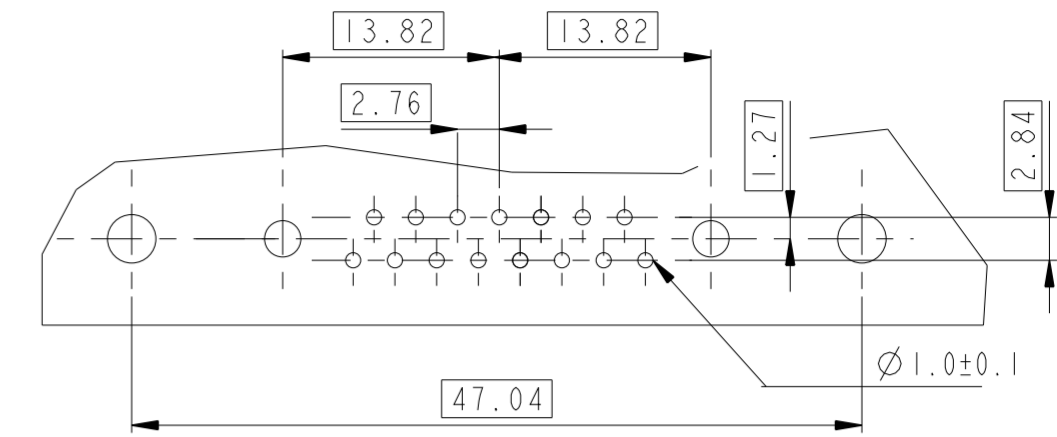

Floating signal contacts

spec ref	dr	1, Product Eng	2015/06/12	projection	MM	size	A2	scale	2:1
tolerance std	eng	Gregar Mathew	2019/11/11			ecn no	ELX-32909-1	rel level	Released
ISO 406	chr	-	app						
ISO 1101	TOLERANCES UNLESS OTHERWISE SPECIFIED			Amphenol FCI	SUB FEMALE DW		dwg no	C01-8639-2302c	
surface	linear	0.X	±0.30	0.XX	±0.10	0.XXX	±0.05	rev	
ISO 1302	angular	0°	±2°	MIXED POWER STRAIGHT SOLDER		cat. no.		Product - Customer Drw	

21W1

LAYOUT AND CONNECTOR DIMENSIONS  
For PCB hole diameters see table I sheet 1

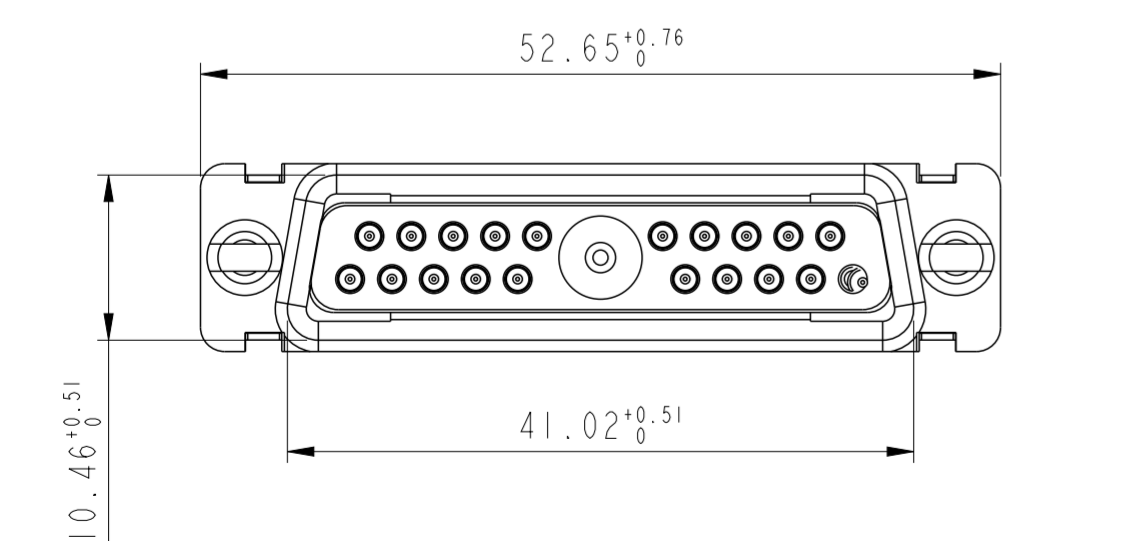
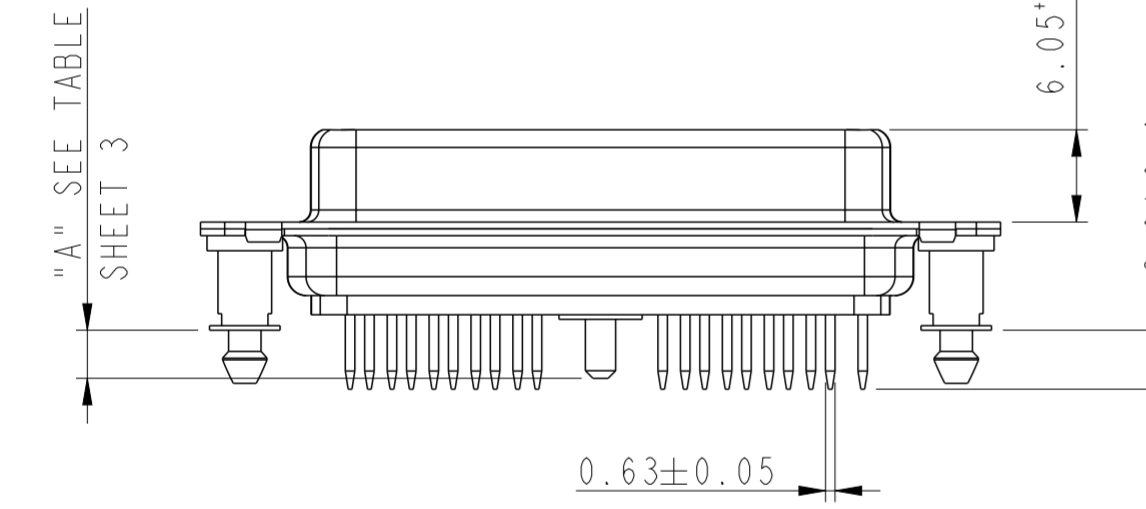
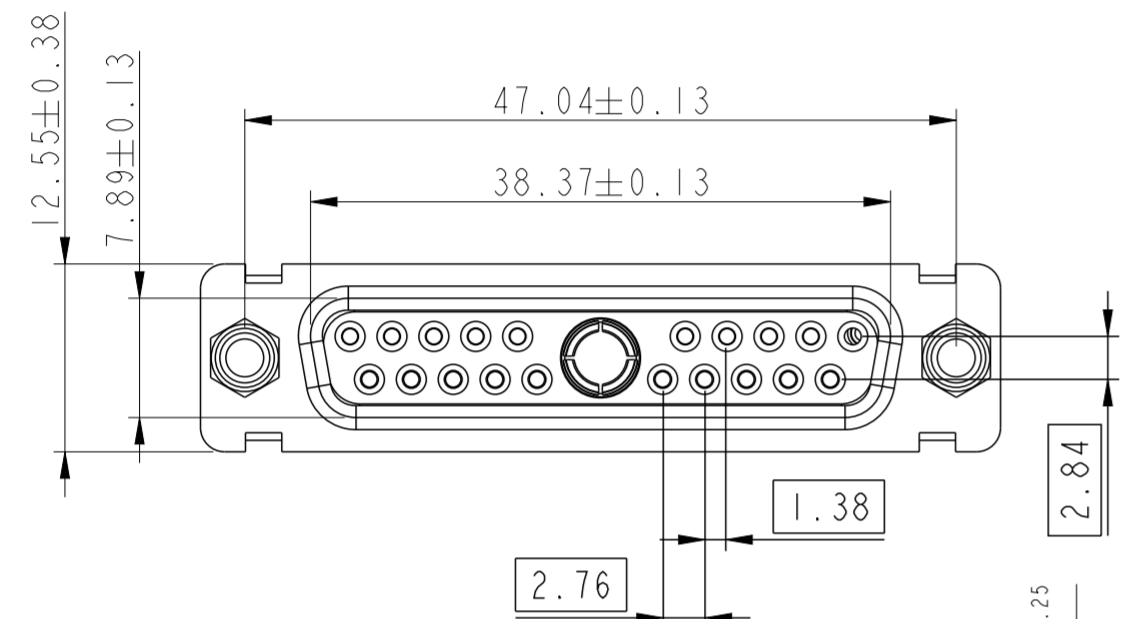
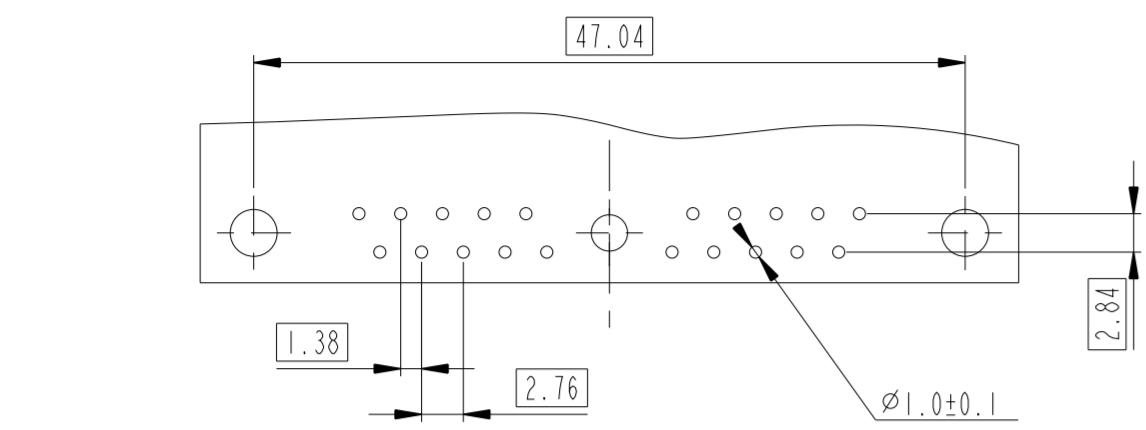

27W2

LAYOUT AND CONNECTOR DIMENSIONS  
For PCB hole diameters see table I sheet 1

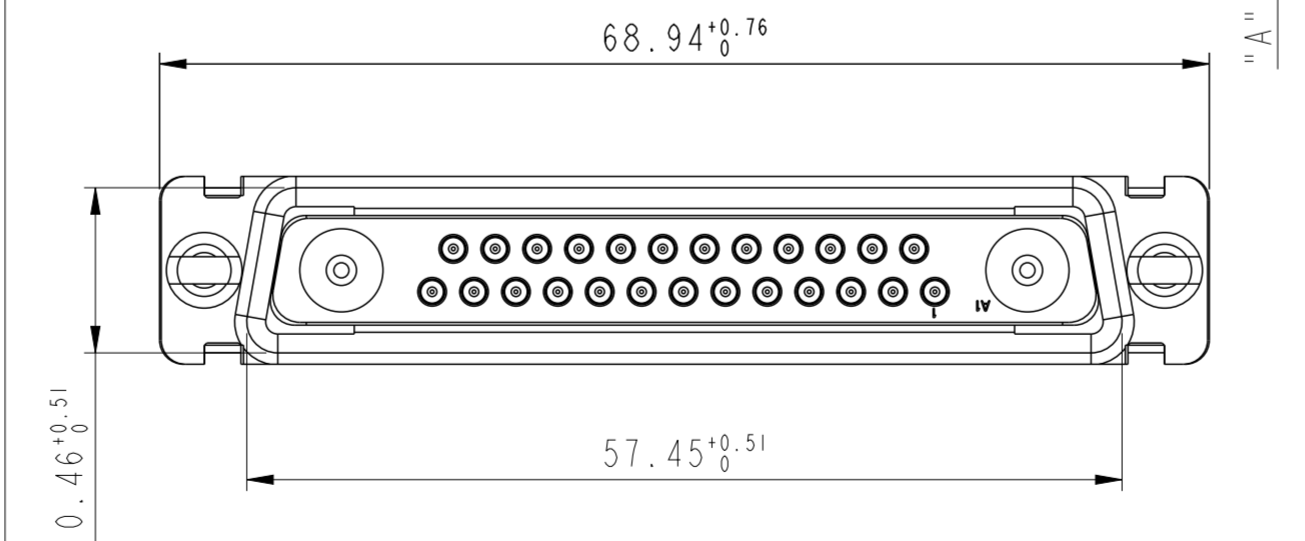
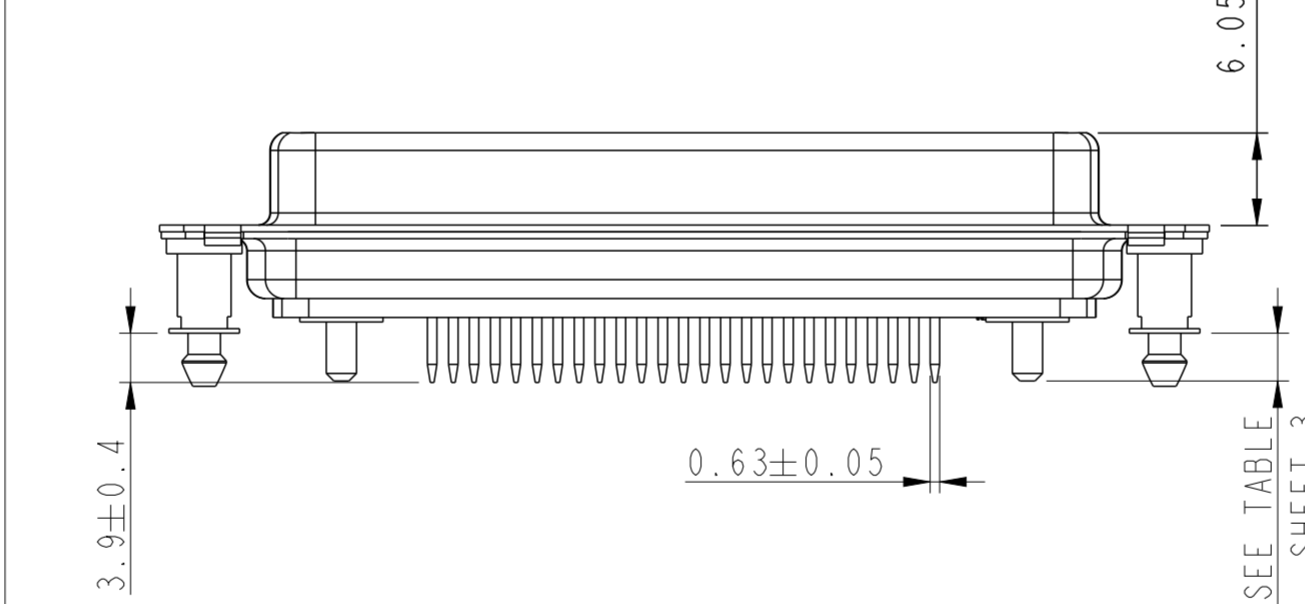
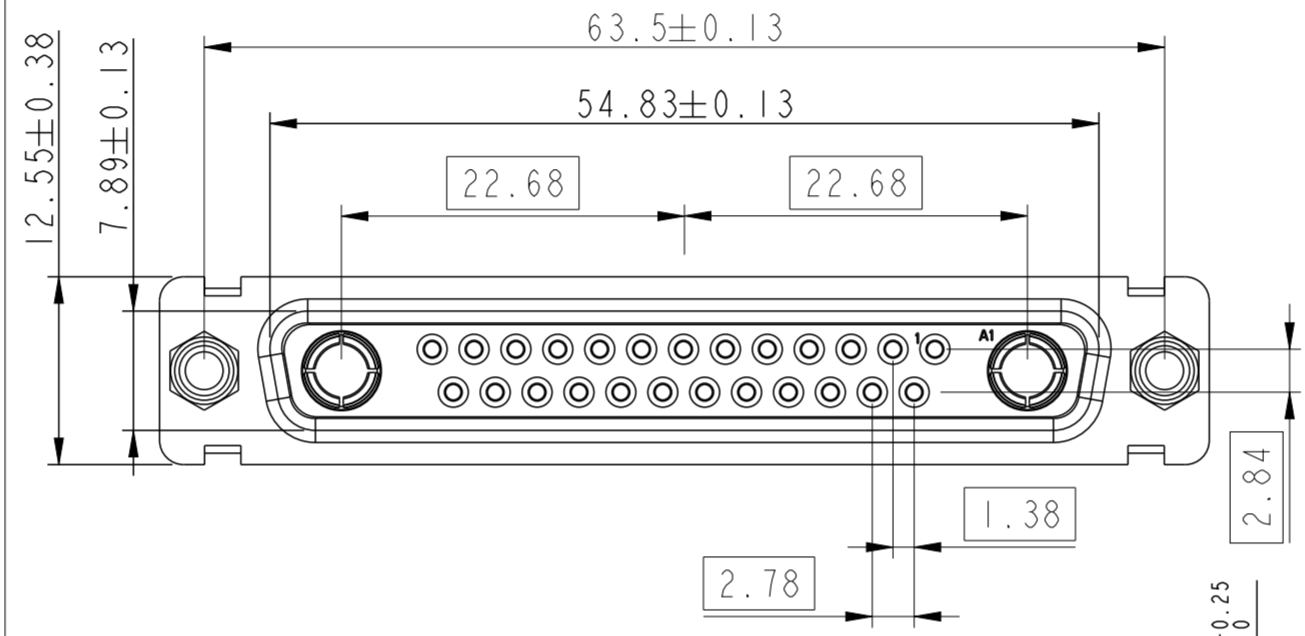
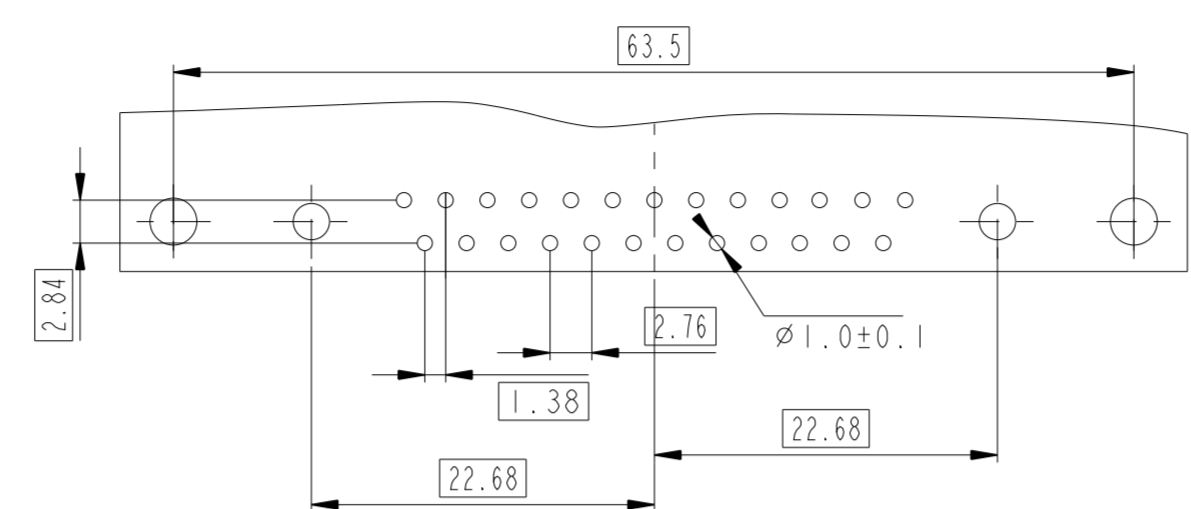

21WA4

LAYOUT AND CONNECTOR DIMENSIONS  
For PCB hole diameters see table I sheet 1

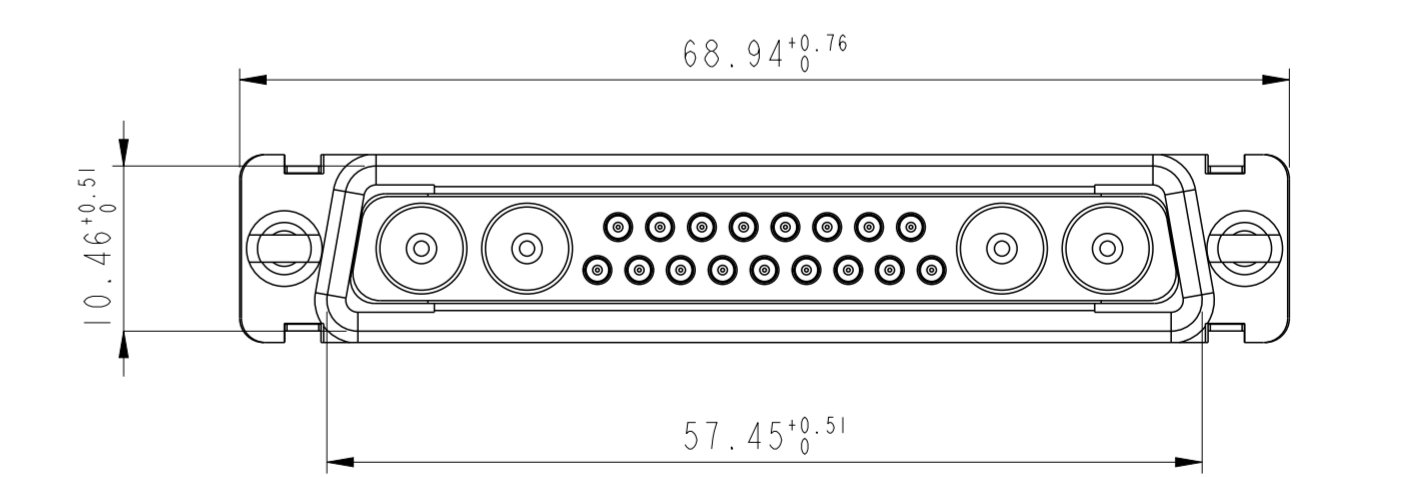
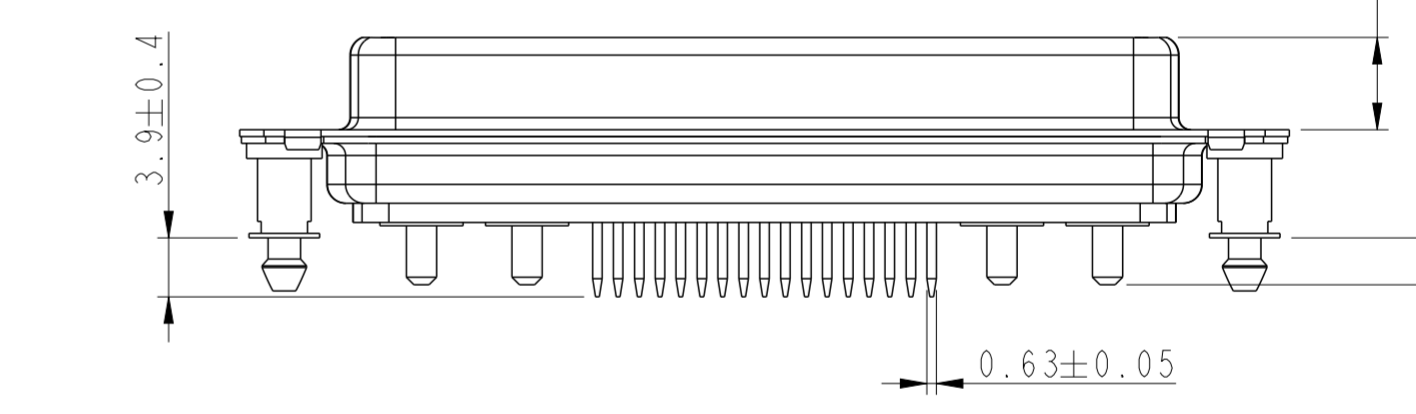
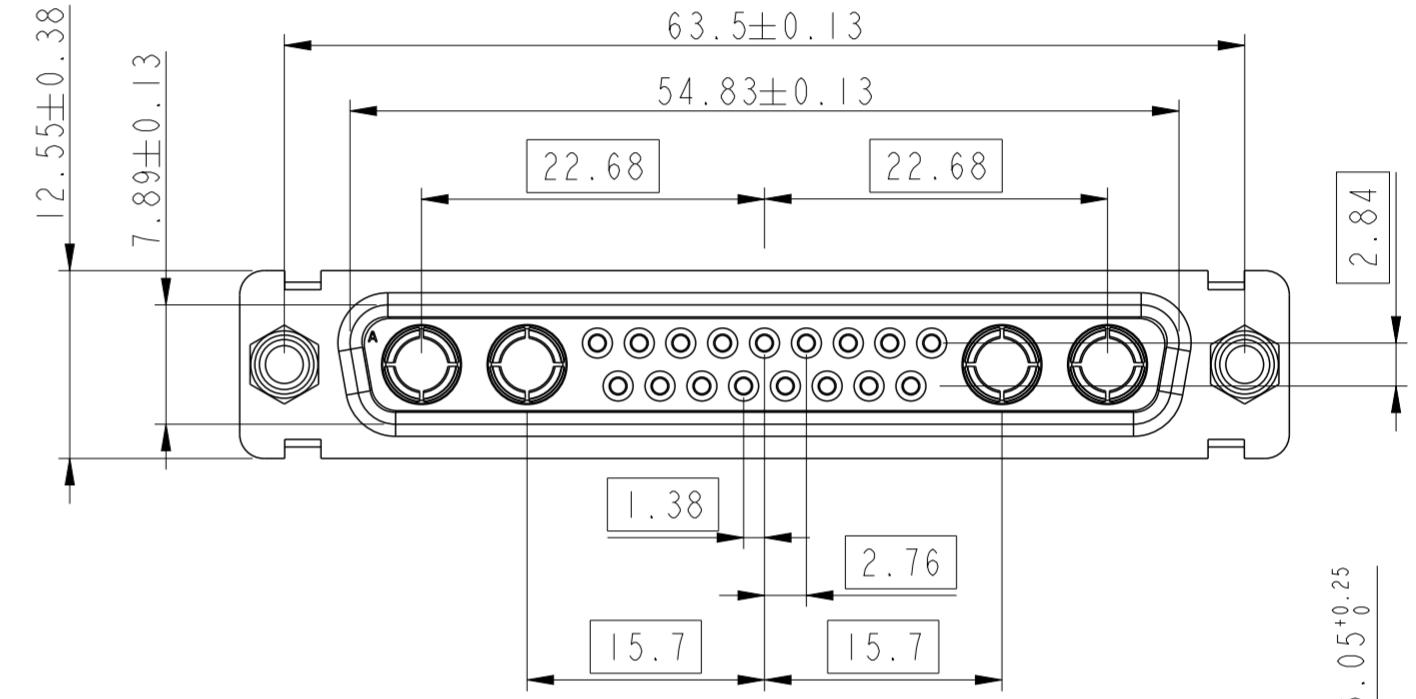
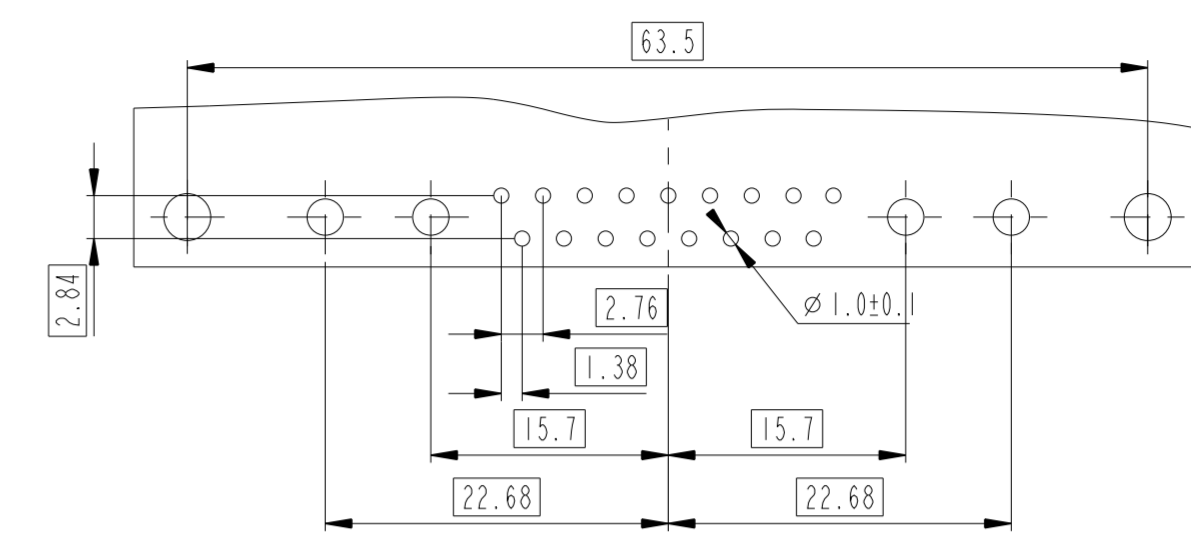

Amphenol FCI

© 2016 AFCI

spec ref	dr	1, Product Eng	2015/06/12	projection	MM	size	A2	scale	2:1		
tolerance std	eng	Gregar Mathew	2019/11/11		ecn no	ELX-32909-1					
ISO 406	chr	-	-			rel level	Released				
ISO 1101	appr	Varma Sudhir	2019/11/12	product family	D SUB						
surface	linear	TOLERANCES UNLESS OTHERWISE SPECIFIED		Amphenol FCI	title	SUB FEMALE DW		dwg no	C01-8639-2302c	rev	K
ISO 1302	angular	0.X	±0.30		cat. no.	-	Product - Customer Drw	sheet 5 of 7			
		0.XX	±0.10								
		0.XXX	±0.05								
		0°	±2°								

PDS: Rev :K

STATUS:Released

Printed: Nov 12, 2019

# 25W3

## LAYOUT AND CONNECTOR DIMENSIONS

For PCB hole diameters see table I sheet 1

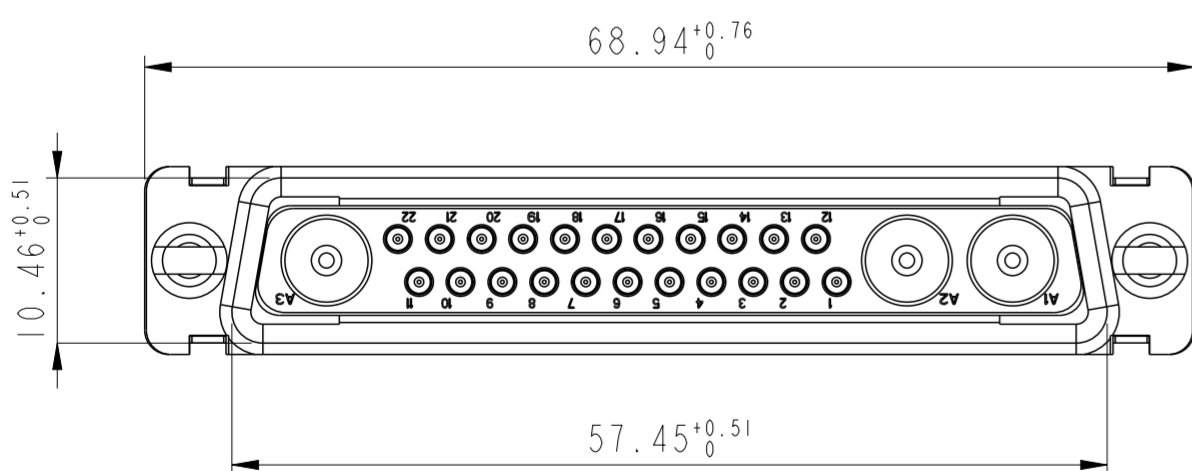
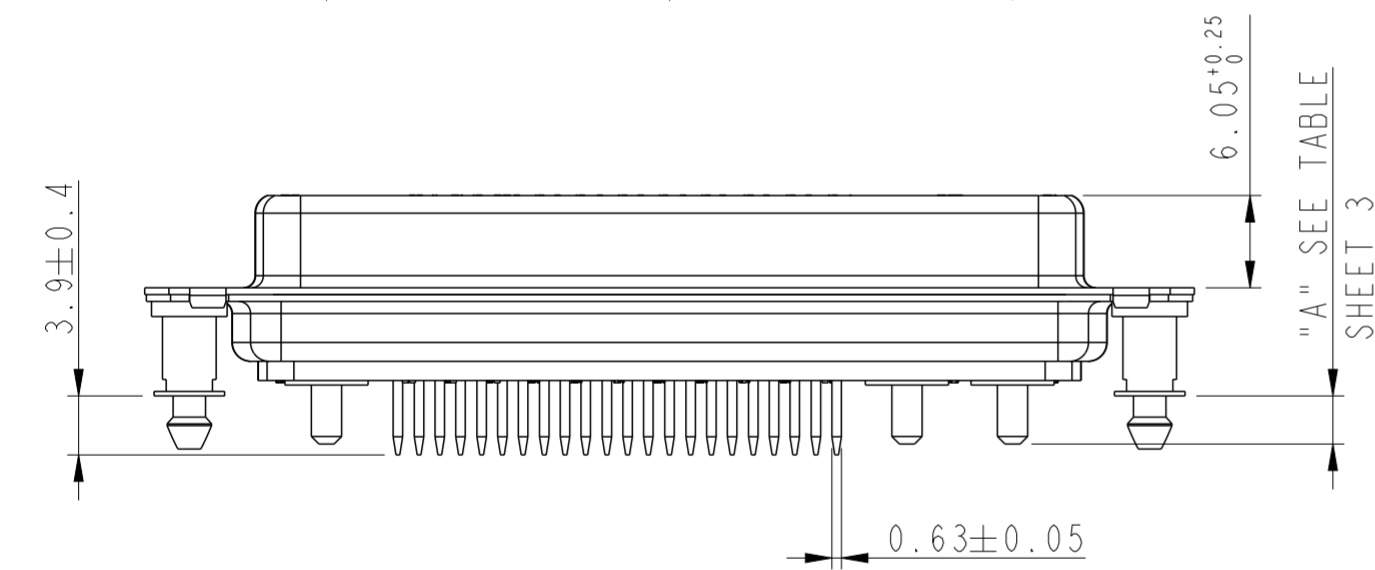
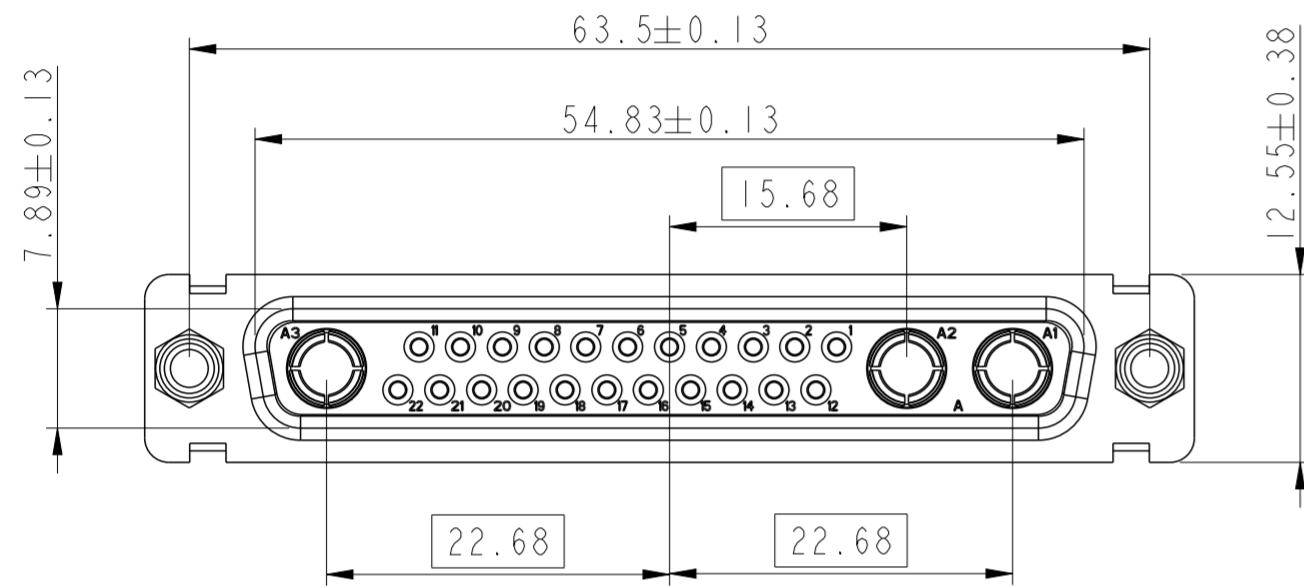
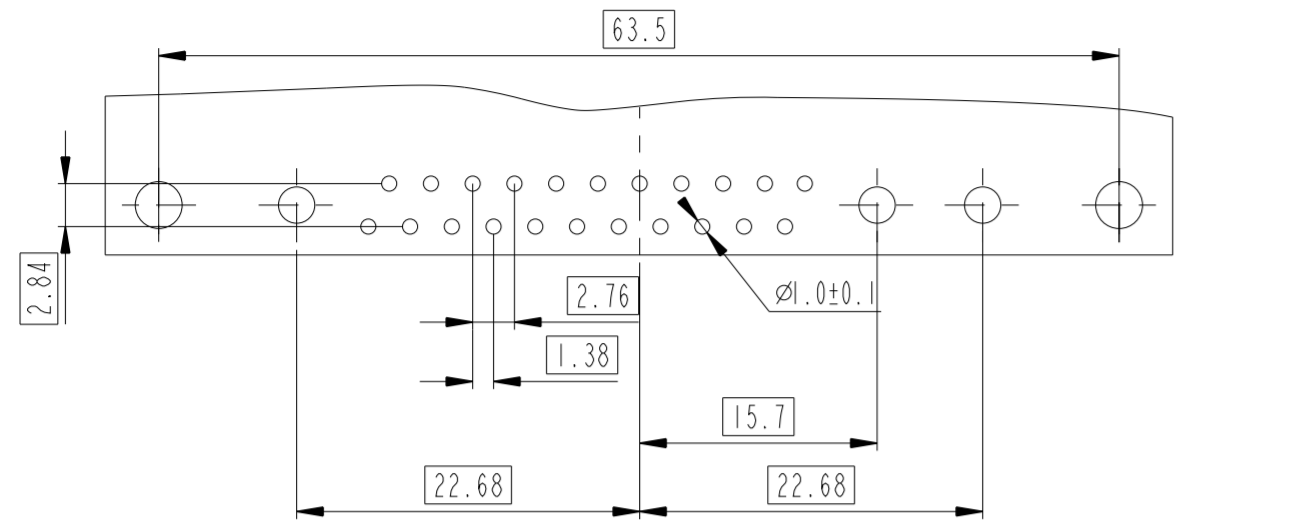

# 24W7

## LAYOUT AND CONNECTOR DIMENSIONS

For PCB hole diameters see table I sheet 1

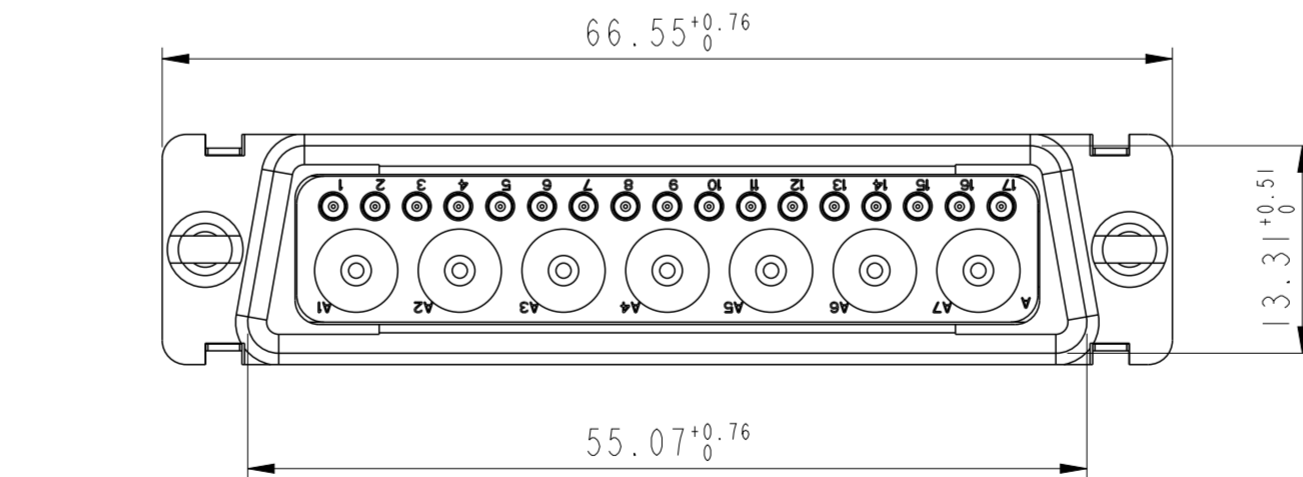
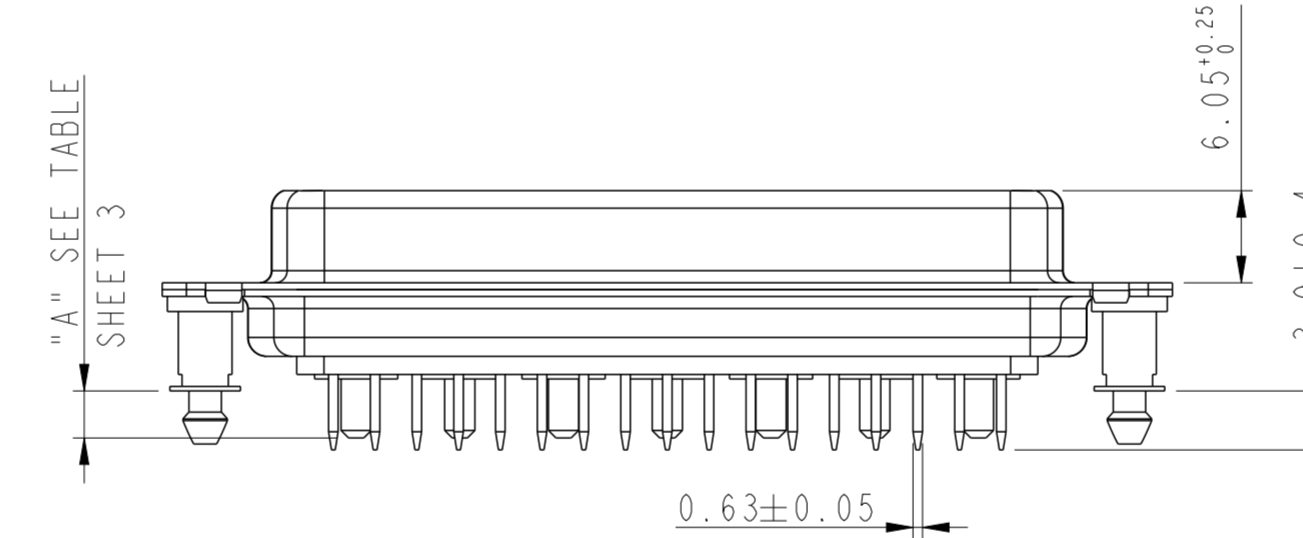
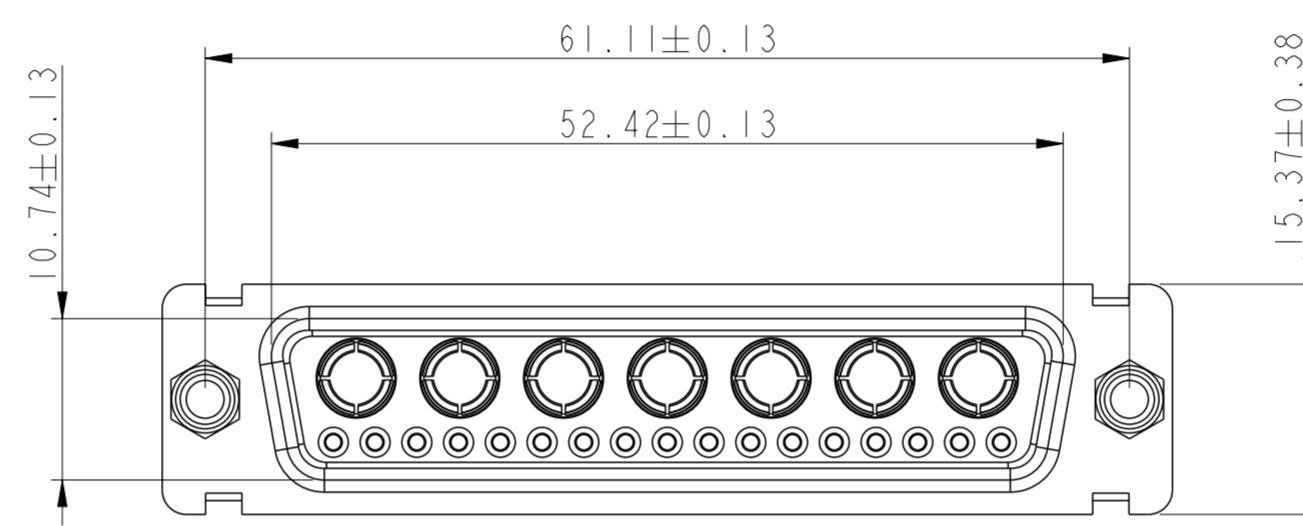
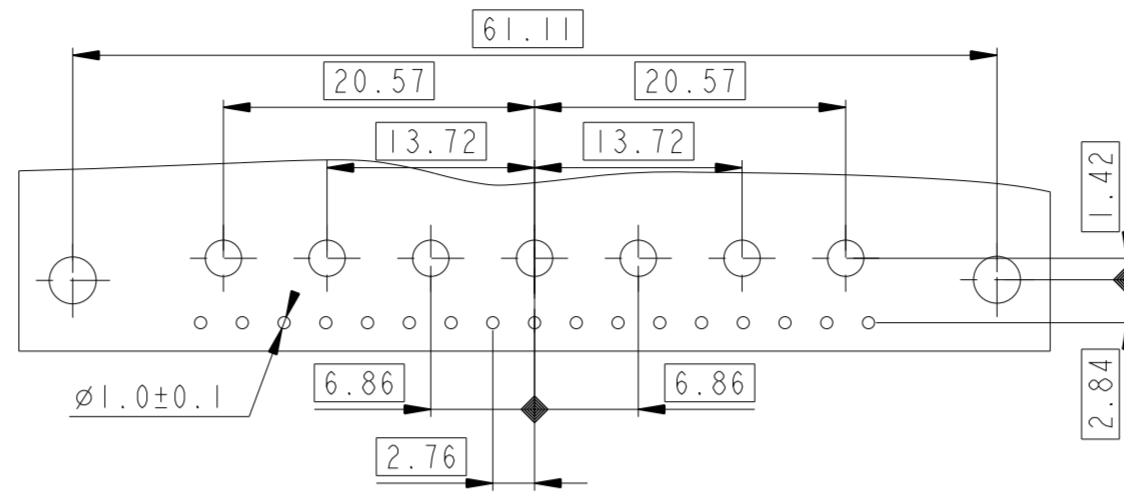

SIDE VIEW FOR LAYOUTS: D

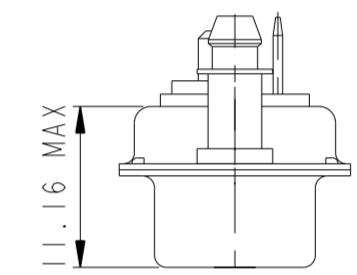

Amphenol FCI

© 2016 AFCI

spec ref	dr	1, Product Eng	2015/06/12	projection	MM	size	A2	scale	2:1
tolerance std	eng	Gregar Mathew	2019/11/11			ecn no	ELX-32909-1	rel level	Released
ISO 406	chr	-	product family						
ISO 1101	appr	Varma Sudhir	2019/11/12	TOLERANCES UNLESS OTHERWISE SPECIFIED		SUB FEMALE DW		cat. no.	-
surface	linear	0.X	±0.30		MIXED POWER STRAIGHT SOLDER		dwg no C01-8639-2302c	rev K	
		0.XX	±0.10		Product - Customer Drw				
		0.XXX	±0.05		sheet 6 of 7				
ISO 1302	angular	0°	±2°	PDS: Rev :K		STATUS: Released		Printed: Nov 12, 2019	

Amphenol  
FCi

© 2016 AFci

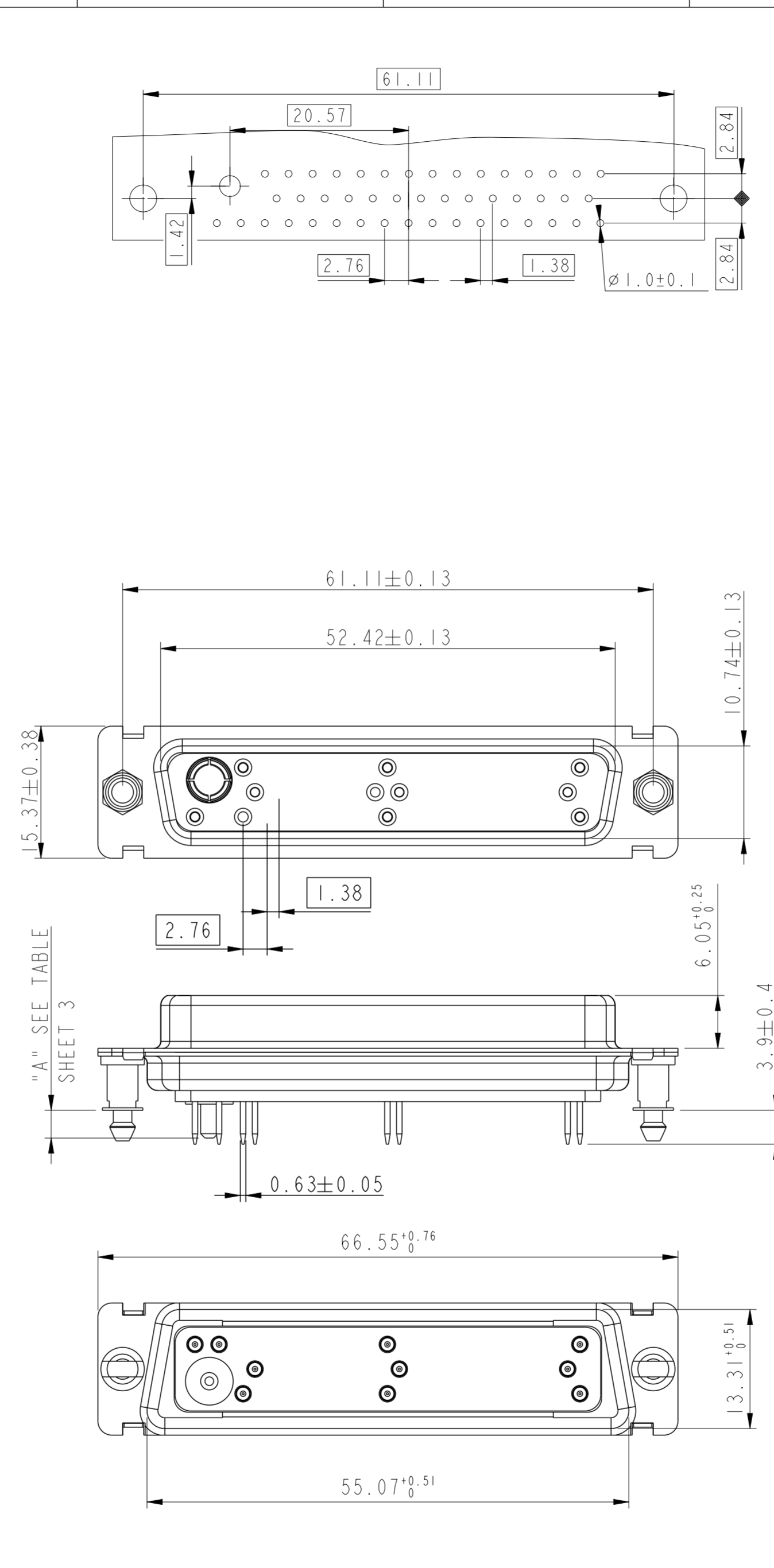
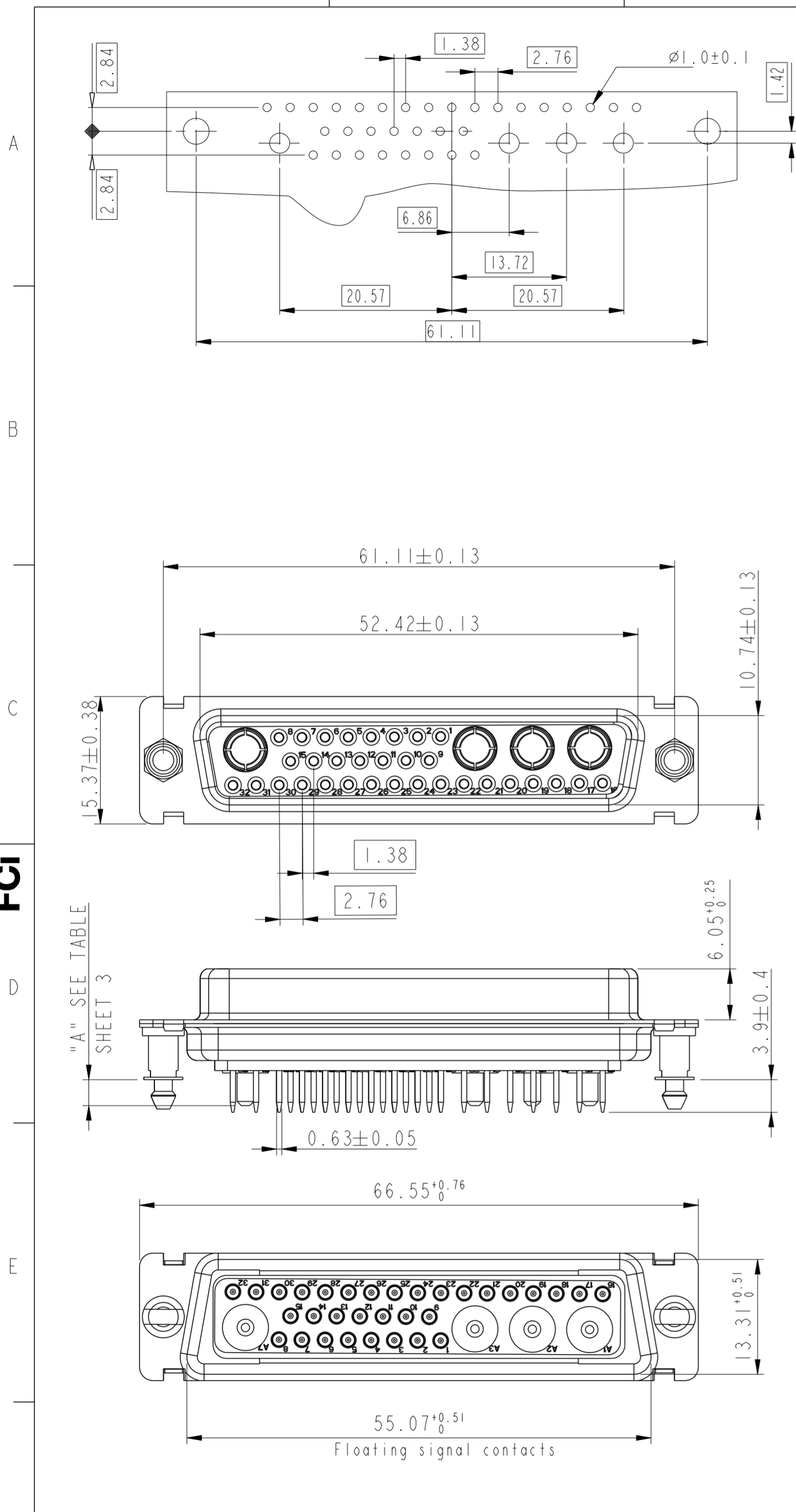

spec ref	dr	1, Product Eng	2015/06/12	projection	MM	size	A2	scale	2:1	
tolerance std	eng	Gregar Mathew	2019/11/11			ecn no	ELX-32909-1	rel level	Released	
ISO 406 ISO 1101	chr	-	product family							D SUB
surface	linear	0.X	±0.30	Amphenol FCi	title	SUB FEMALE DW	cat. no.	Product - Customer Drw	sheet 7 of 7	
		0.XX	±0.10							
ISO 1302	angular	0°	±2°			MIXED POWER STRAIGHT SOLDER				
						dwg no	C01-8639-2302c		rev	K

PDS: Rev :K

STATUS:Released

Printed: Nov 12, 2019