

PART NUMBER SCHEME:

10159561-X X X X X X X X F

LEAD FREE

X	POWER POSITION
2	2
3	3
4	4
5	5
6	6
7	7
8	8
9	9
A	10

X	FOR HEADER, SEE DWG. NO. 10159560			
COMBINATION OF MATED HEIGHT	HEADER 1 HEIGHT: 1.3	HEADER 2 HEIGHT: 2.3	HEADER 3 HEIGHT: 3.3	HEADER 4 HEIGHT: 4.3
RECEPTACLE 1 HEIGHT: 3.7				
RECEPTACLE 2 HEIGHT: 7.7				
RECEPTACLE 3 HEIGHT: 11.7				
RECEPTACLE 4 HEIGHT: 15.7				

X	PLATING: CONTACT AREA
1	GOLD 0.05um MIN
2	GOLD OR GXT 0.2um MIN
3	GOLD OR GXT 0.375um MIN
4	GOLD OR GXT 0.75um MIN

X	POLARIZATION PEG/ DATE CODE
L	WITH PEG/ WITHOUT DATE CODE
P	WITH PEG/ WITH DATE CODE
M	WITHOUT PEG/ WITHOUT DATE CODE
N	WITHOUT PEG/ WITH DATE CODE

X	SOLDER TAIL PLATING: POWER PIN
1	GOLD FLASH

X	PACKAGING
R	T&R WITH MYLAR
T	TUBE WITHOUT MYLAR
Q	T&R WITHOUT MYLAR

X	EMPTY PIN OPTIONAL
0	NONE
2	2#
3	3#
4	4#
5	5#
6	6#
7	7#
8	8#
9	9#

X	CUSTOMER OPTIONAL
0	GENERAL
E	E CUSTOMIZED

DATE CODE: XXXXXX

DAY (01~32)
MONTH (01~12)
YEAR (00~99)

NOTES:

- MATERIAL:
 - HOUSING: THERMOPLASTICNOTES, NATURAL, UL94V-0.
 - POWER CONTACT: COPPER ALLOY
 - HOLD DOWN: COPPER ALLOY
- PLATING:
 - UNDER PLATING: 1-3um NI UNDER PLATING;
 - CONTACT AREA: ACCORDING TO PART NUMBER;
 - SOLDER TAIL:
 - POWER CONTACT: ACCORDING TO PART NUMBER;
 - HOLD DOWN: TIN PLATIN.
- PRODUCT SPEC GS-12-1675
- APPLICATION GS-20-0696
- THIS HOUSING WILL WITHSTAND EXPOSURE TO 260°C PEAK TEMPERATURE FOR 20 SECONDS IN A IR REFLOW SOLDERING APPLICATION.
- THIS PRODUCT MEETS EUROPEAN UNION DIRECTIVES AND OTHER COUNTRY REGULATIONS AS DESCRIBED IN GS-47-0004.
- COPLANARITY AREA OF TERMINATION 0.10MM MAX.

spec ref	dr	Li-Qing Lei	2021/03/23	projection	mm	size	A3	scale	1:1
tolerance std	eng	Li-Qing Lei	2023/07/13		← →	ecn no	ELX-N-48555-1	rel level	Released
TOLERANCES UNLESS OTHERWISE SPECIFIED		chr	-						
surface	linear	0.X	±0.5	Amphenol FCI	RECEPTACLE	dwg no	10159561	rev	F
		0.XX	±0.25						
		0.XXX	±0.10						
	angular	0°	±2°	cat. no.	Product - Customer Drw	sheet 1 of 3			

RECEPTACLE 1

Dimension	Computational Formula
DIM "A"	(POSITION-1) X 2 + 5.6
DIM "B"	(POSITION-1) X 2 + 3
DIM "C"	(POSITION-1) X 2

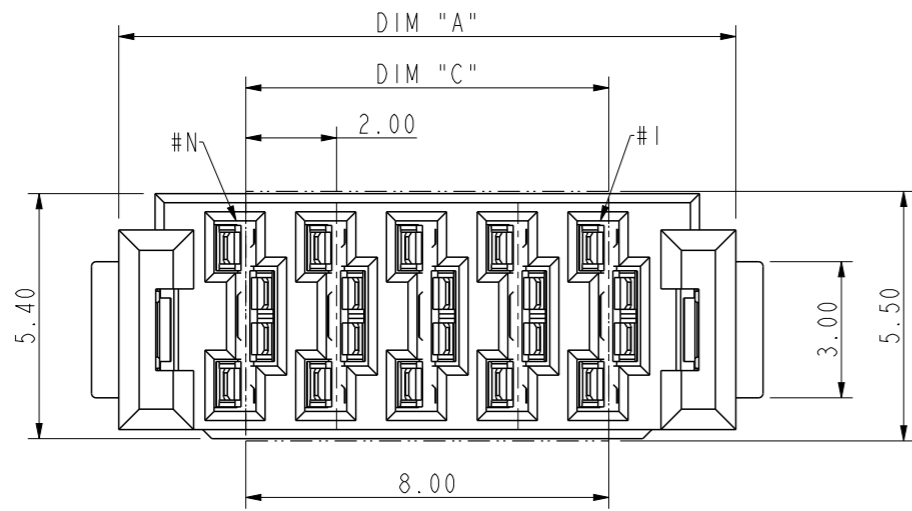

PCB LAYOUT PROPOSAL FOR RECEPTACLE 1
TOLERANCE RECOMMENDED ±0.05

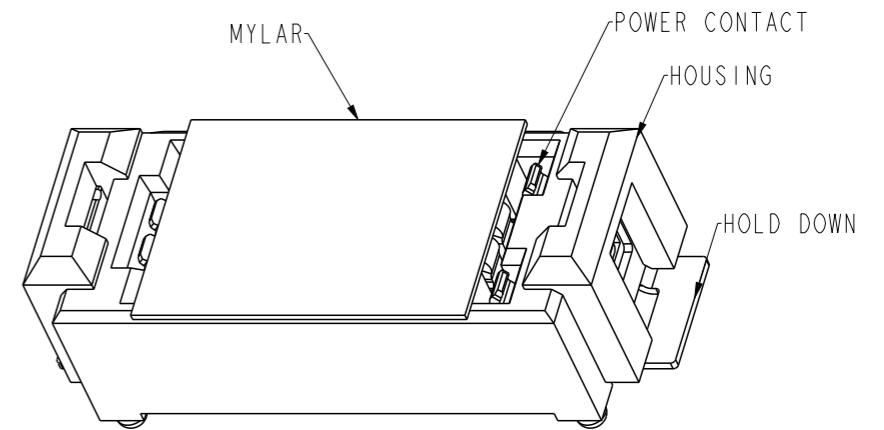
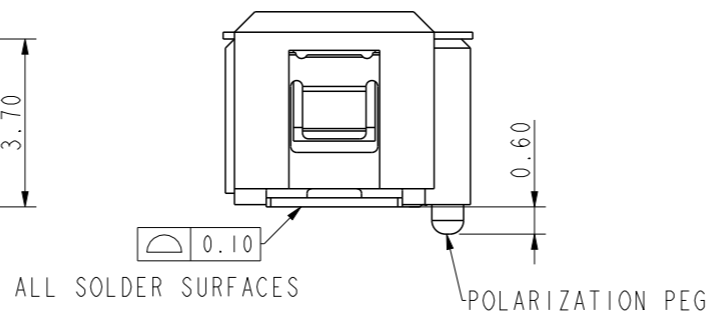
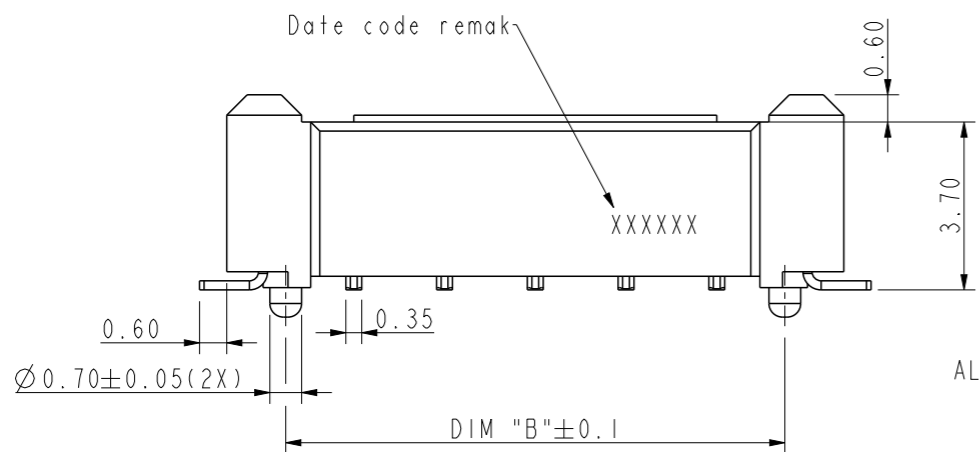
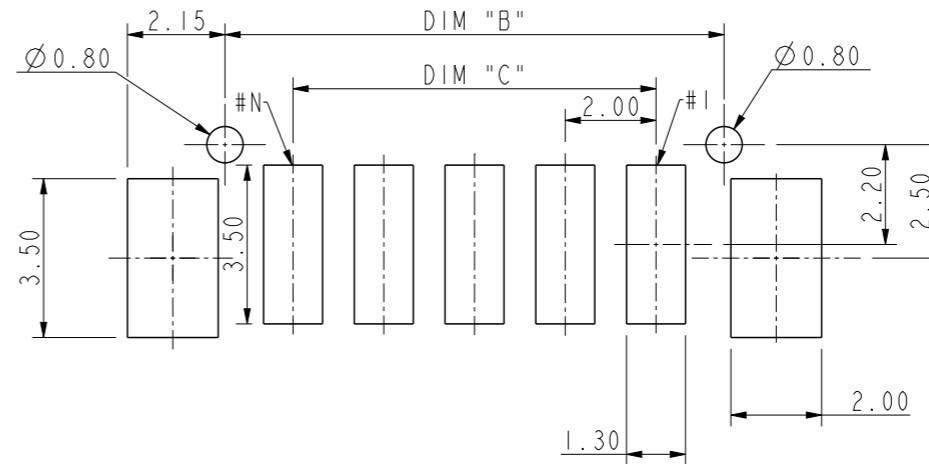

spec ref	dr	Li-Qing Lei	2021/03/23	projection	mm	size	A3	scale	6:1
tolerance std	eng	Li-Qing Lei	2023/07/13			ecn no	ELX-N-48555-1	rel level	Released
TOLERANCES UNLESS OTHERWISE SPECIFIED									
surface	linear	0.X	±0.5	Amphenol FCI		RECEPTACLE PowerStak Connector	dwg no 10159561	rev F	
		0.XX	±0.25						
		0.XXX	±0.10						
	angular	0°	±2°	cat. no.	Product - Customer Drw	sheet 2 of 3			

RECEPTACLE 2/3/4

Dimension	Computational Formula
DIM "A"	(POSITION-1) X 2 + 5.6
DIM "B"	(POSITION-1) X 2 + 5
DIM "C"	(POSITION-1) X 2
DIM "D"	(POSITION-1) X 2 + 8.9

PRODUCT	DIM "D"
RECEPTACLE 2	7.7
RECEPTACLE 3	11.7
RECEPTACLE 4	15.7

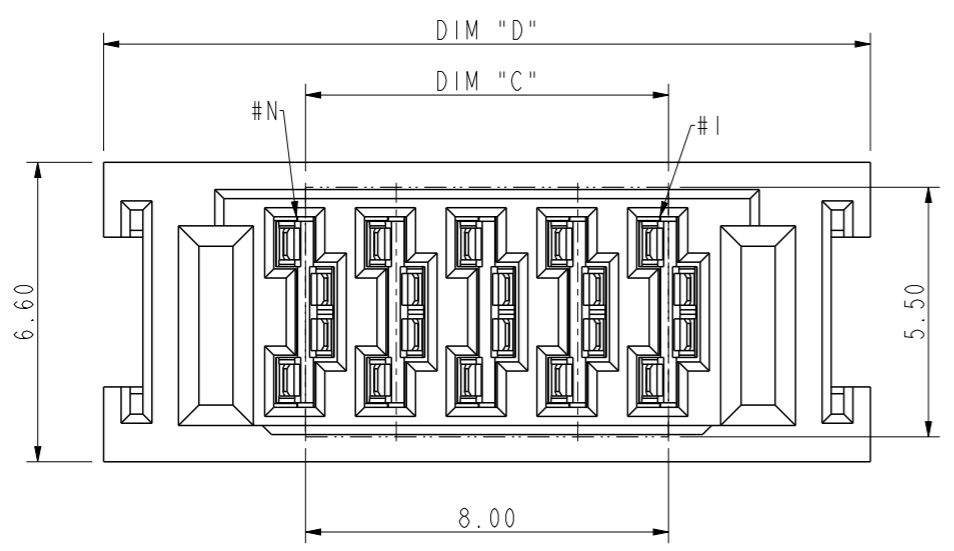

PCB LAYOUT PROPOSAL FOR RECEPTACLE 2/3/4
TOLERANCE RECOMMENDED ±0.05

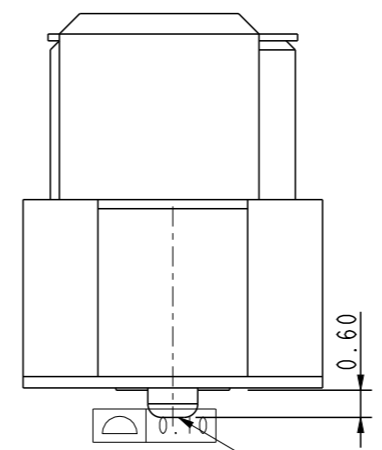
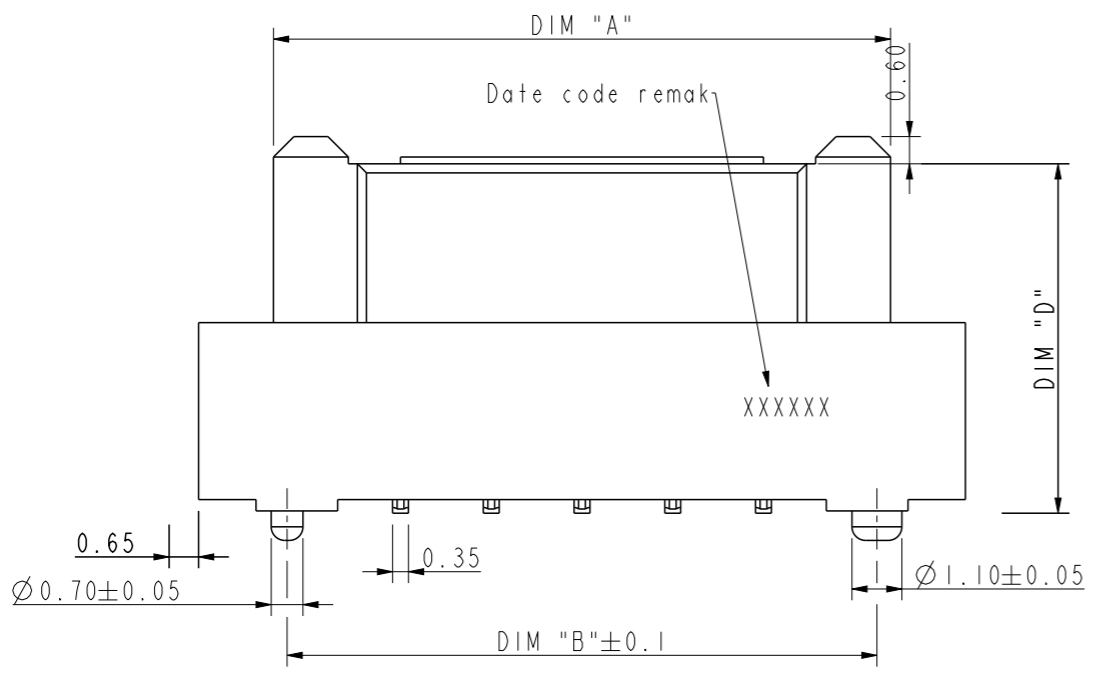
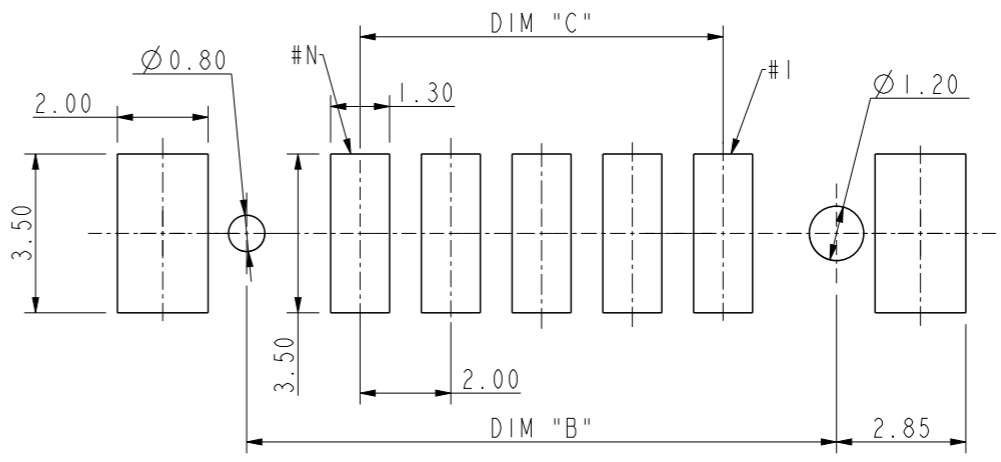

ALL SOLDER SURFACES POLARIZATION PEG

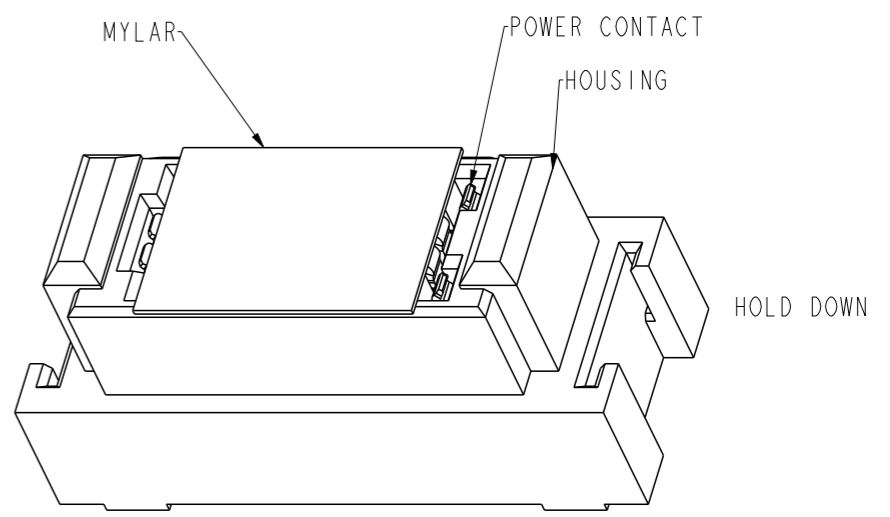

spec ref	dr	Li-Qing Lei	2021/03/23	projection	mm	size	A3	scale	1:1
tolerance std	eng	Li-Qing Lei	2023/07/13			ecn no	ELX-N-48555-1		
TOLERANCES UNLESS OTHERWISE SPECIFIED						product family	rel level	Released	
surface	linear	0.X	±0.5	Amphenol FCI		RECEPTACLE PowerStak Connector	dwg no 10159561	rev F	
		0.XX	±0.25						
		0.XXX	±0.10						
	angular	0°	±2°	cat. no.	Product - Customer Drw	sheet 3 of 3			

Creo File:ELX-WC-A3C.REV F.2020-12-21