

AFCI CONFIDENTIAL

Amphenol
FCI

This document is the property of and embodies CONFIDENTIAL and PROPRIETARY information of AFCI. No part of the information shown on this document may be used in any way or disclosed to others without the written consent of AFCI.

PRODUCT NO.	MATERIAL COLOR	MATERIAL TYPE
65824-001	BLUE	POLYESTER PET OR POLYESTER PBT
65824-002	BLACK	POLYESTER PBT
65824-003	GRAY	POLYESTER PBT
65824-004	BLACK	POLYESTER PET
65824-005	BLACK	POLYPHENYLENE SULFIDE PPS
65824-006	BLUE	POLYESTER PBT
65824-007	BLACK	POLYESTER PCT OR PA9T

- NOTES
- MATERIAL TYPE AND COLOR: SEE TABLE.
FLAME RETARDANT PER UL94V-0
 - ADD 'LF' SUFFIX AT THE END OF PART NUMBER FOR LEAD FREE OPTION.
 - IF 'LF' P/N THE PRODUCT MEETS EUROPEAN UNION DIRECTIVES AND OTHER COUNTRY REGULATION AS DESCRIBED IN GS-22-008.
 - THE HOUSING WILL WITHSTAND EXPOSURE TO 260° PEAK TEMPERATURE FOR 15 SECONDS IN A WAVE SOLDER APPLICATION WITH A 1.5mm MINIMUM THICK CIRCUIT BOARD. SEE APPLICATION NOTES/PROCEDURES IF THEY ARE AVAILABLE.

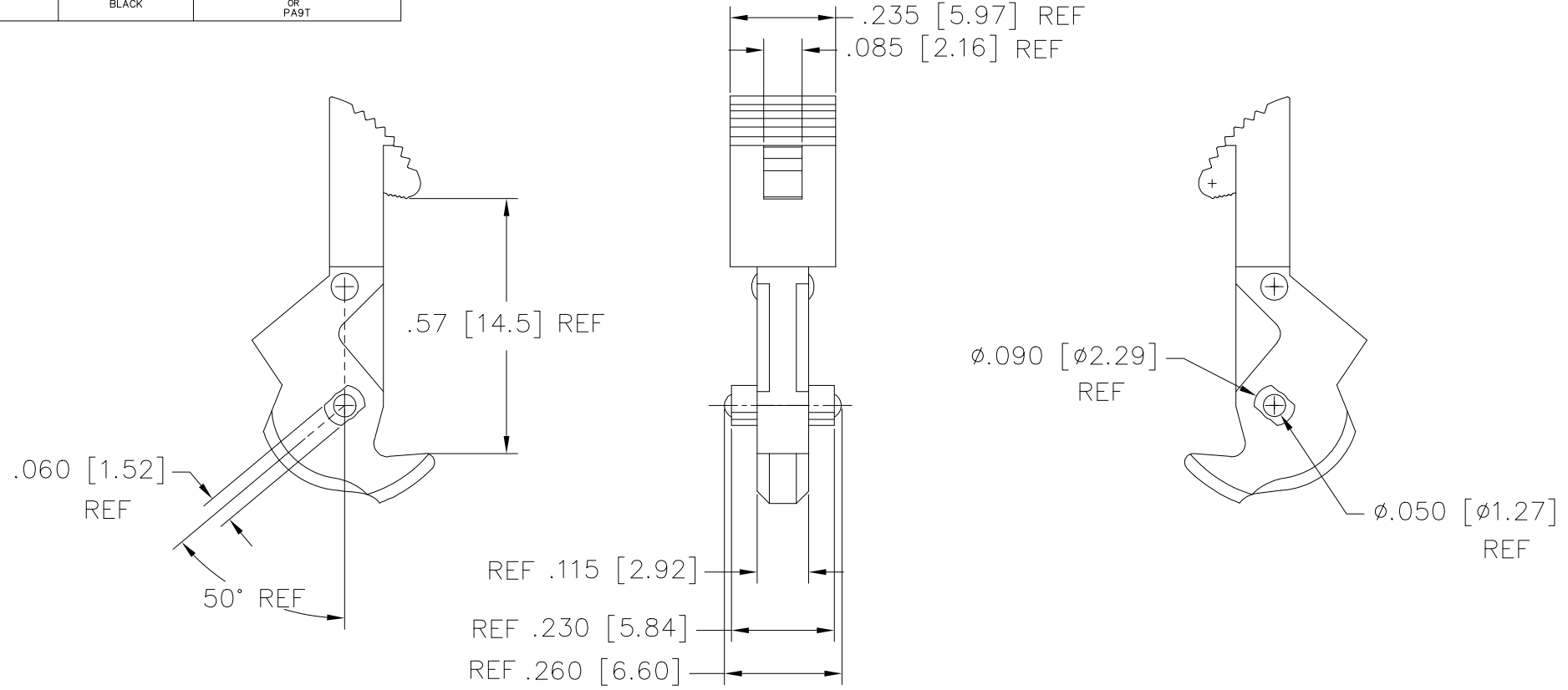

mat'l. code				surface ISO 1302 ✓		tolerance ISO 406 ISO 1101		projection MM		product family LATCHES	
ltr	ecn no	dr	date	tolerances unless otherwise specified		linear		scale 1:1		title SEA-HORSE LATCH	
J	Y23800	MSC	02/23/93	.X±0.3						dwg no	
K	V31706	MSC	11/02/93	.XX±0.13						sheet 1 of 1	
L	V61149	EPK	8/15/96	.XXX±0.051						size	
M	N06-0112	LONG	04/08/06	dr	D.WHITING	6/12/90		Amphenol FCI		65824	
N	ELX-N-41277	MKX	06/23/21	chr	M.SMYK	6/12/90				A3	
				appd	M.SMYK	6/12/90				type Product Customer Drawing	
sheet index	revision	AM									
	sheet	1-2									