

| PRODUCT NUMBER | TAIL LGTH. DIM "A" | PCB THICKNESS |
|----------------|--------------------|---------------|
| 89093-X02LF | 2.90 | 1.6 |
| 89093-X12LF | 3.53 | 2.4 |

+0.40
0-0.10
RELATIVE TO SURFACE T

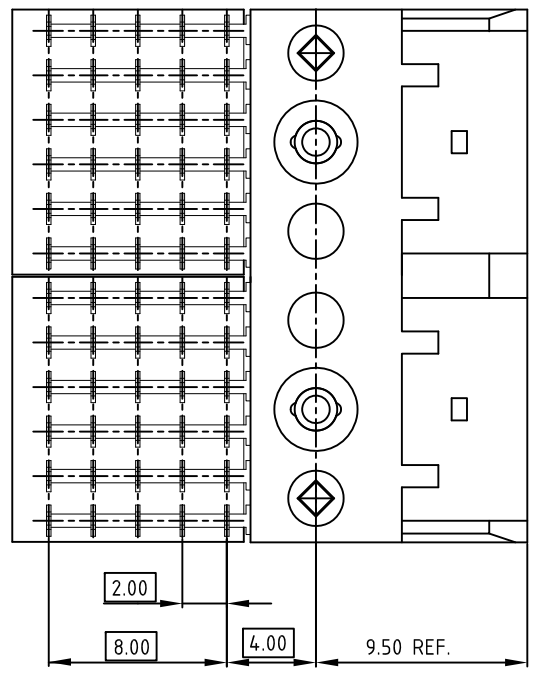
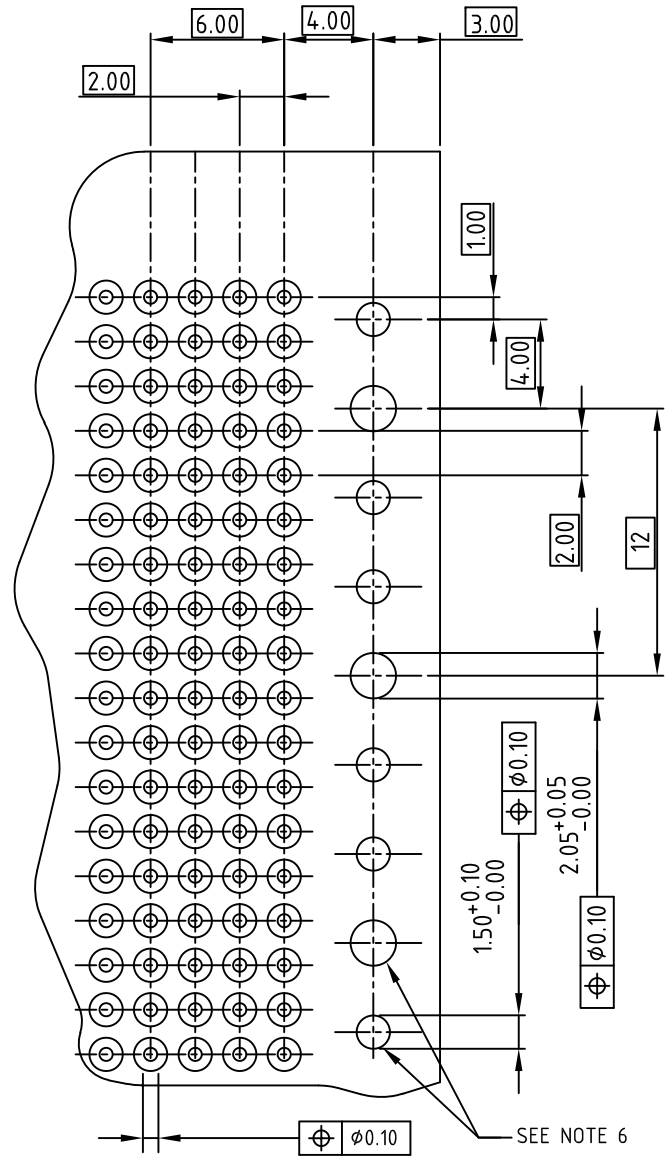
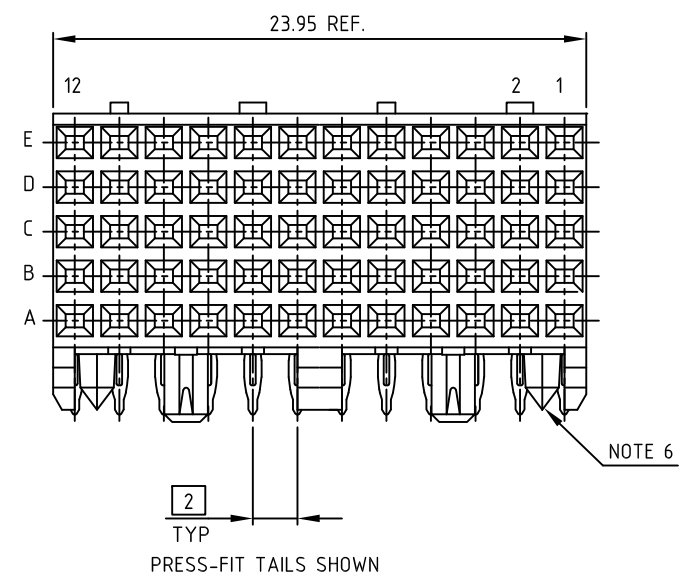
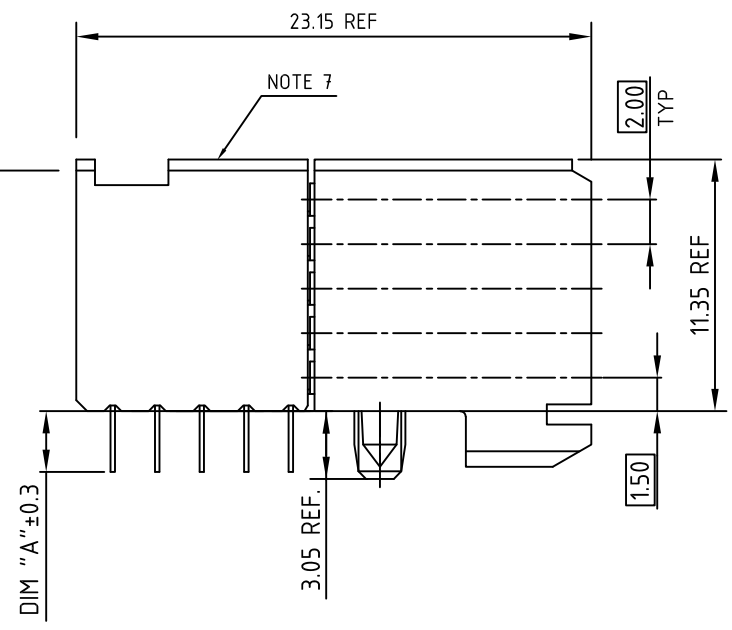

NOTES:

- MATERIAL : BODY : THERMOPLASTIC UL94-V0
: CONTACT : COPPER ALLOY.
- FOR PLATING PERFORMANCE REFER DRAWING # 10159408 Δ
- PRODUCT SPECIFICATION : GS-12-002
- APPLICATION SPECIFICATIONS : BUS-20-061 , GS-20-001,TA-941
- INDICATED HOLES ARE UNPLATED
- DIAMOND LOCATION PEG ARE ONLY EXISTED ON THE BOTH SIDES OF PRODUCT.
- TOP SURFACE OF PRESS BLOCK MAY EXTEND UP TO 0.4MM HIGHER THAN HOUSING. THIS MAY AFFECT THE TAIL LENGTH BEFORE APPLICATION TO A BOARD.
- THIS PRODUCT MEETS EUROPEAN UNION DIRECTIVES AND OTHER COUNTRY REGULATIONS AS DESCRIBED IN GS-47- 0004
- ALL PRODUCTS WILL WITHSTAND EXPOSURE TO 240°C FOR 60 SECONDS IN A CONVECTION, INFAR-RED OR VAPOR PHASE REFLOW OVEN.
- A Δ SYMBOL WILL BE NEXT TO ANY DIMENSION, VIEW, OR NOTE WHICH HAS BEEN MODIFIED WITH THE CURRENT DRAWING REVISION.

RECOMMENDED PC BOARD LAYOUT,
COMPONENT SIDE.
FOR PTH DETAILS REF DRAWING NO # 58351

REFER NOTE 2
PART NUMBER : 89093-XYLFF

| | | | | | | | | | | | |
|-------------|--|----------------|--|--|--|-------------------------------|--|----------------|--|---|--|
| mat'l. code | | | | surface ISO 1302 <input checked="" type="checkbox"/> ISO 406 ISO 1101 | | tolerance ISO 406 ISO 1101 | | projection | | product family METRAL | |
| ltr | | | | ecn no | | dr | | date | | title | |
| P | | | | DG07-0168 | | CENH | | 2007-05-10 | | B SERIES R/A SIGNAL RECEPT ASSY 5 ROW, 2 MOD, PF | |
| R | | | | DG08-0171 | | TER | | 2008-08-26 | | | |
| S | | | | DG09-0068 | | CENH | | 2009-06-06 | | | |
| T | | | | ELX-I-39007 | | MINI | | 2020-11-18 | | dwg no | |
| | | | | | | | | dr | | sheet 1 of 1 | |
| | | | | | | | | C.DAILY | | size | |
| | | | | | | | | 2002-06-18 | | A3 | |
| | | | | | | | | engr | | type | |
| | | | | | | | | ARUN | | Product Customer Drawing | |
| | | | | | | | | 2020-11-18 | | | |
| | | | | | | | | chr | | | |
| | | | | | | | | ALEX BABU | | | |
| | | | | | | | | 2020-11-18 | | | |
| | | | | | | | | appd | | | |
| | | | | | | | | SAN0J | | | |
| | | | | | | | | 2020-11-18 | | | |
| sheet index | | revision sheet | | T | | 1 | | | | | |