

PART NUMBER
85826-XXX(L)LF

L REFER LUBRICATED (OPTIONAL)
SEE NOTE 3

X REFER PLATING PERFORMANCE
SEE NOTE 3

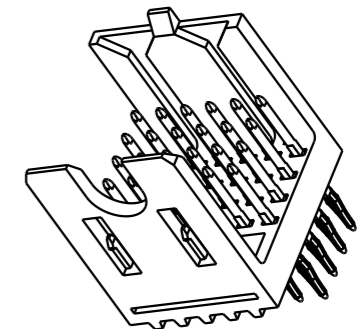
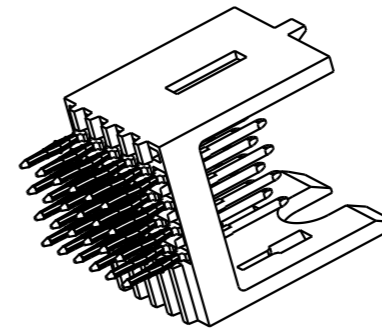
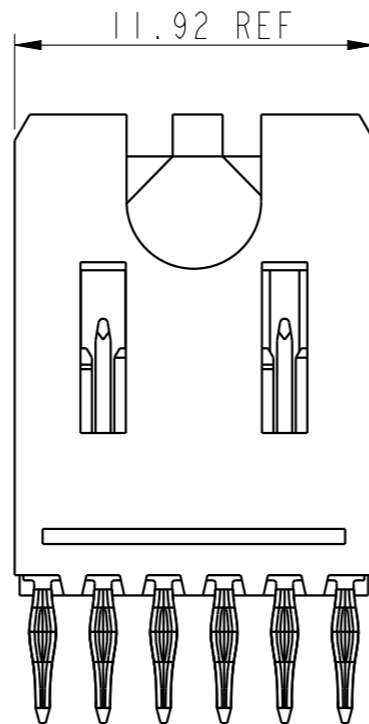
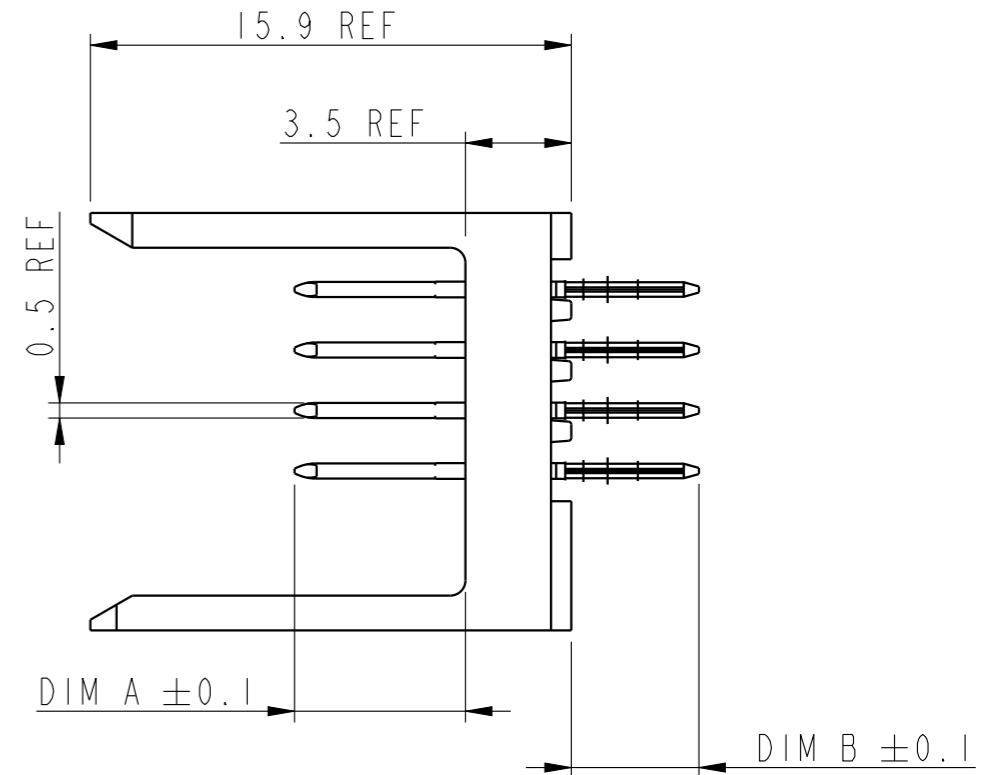
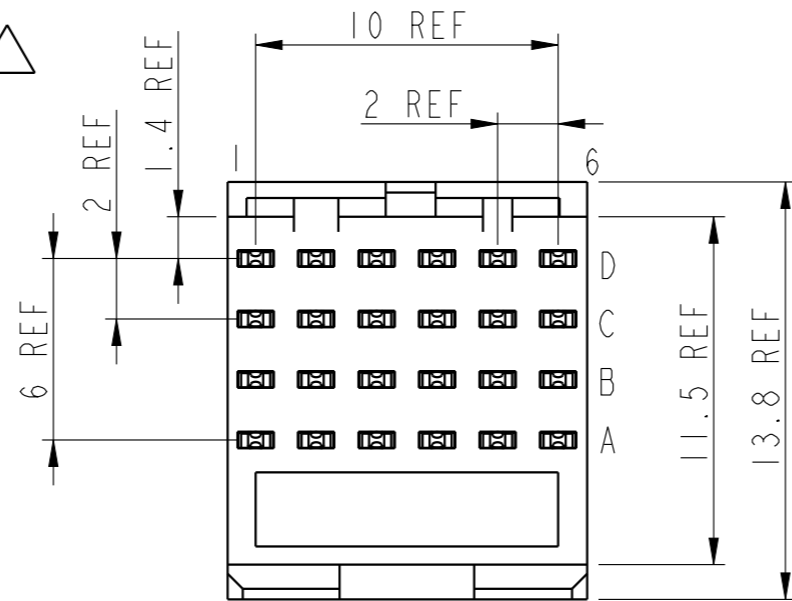

GENERAL CHARACTERISTICS AND RoHS INFORMATIONS:
SEE DRAWING C-8626-000P

spec ref	-	dr	Terran Huang	2010/07/09	projection	MM	size	A3	scale	1:1	
tolerance std	ISO 406 ISO 1106	eng	Rahul Mohan-M	2021/07/21			ecn no	ELX-I-41718-1			
TOLERANCES UNLESS OTHERWISE SPECIFIED		chr	-	-			rel level	Released			
surface	linear	appr	Kuriakose, San	2021/08/16	product family	-	dwg no	85826		rev	N
ISO 1302	angular	Amphenol FCI		METRAL SIGNAL STRAIGHT HEADER		cat. no.		SEE NOTES	Product - Customer Drw	sheet 1 of 8	

1

2

3

4

A

B

C

D

A

B

C

D

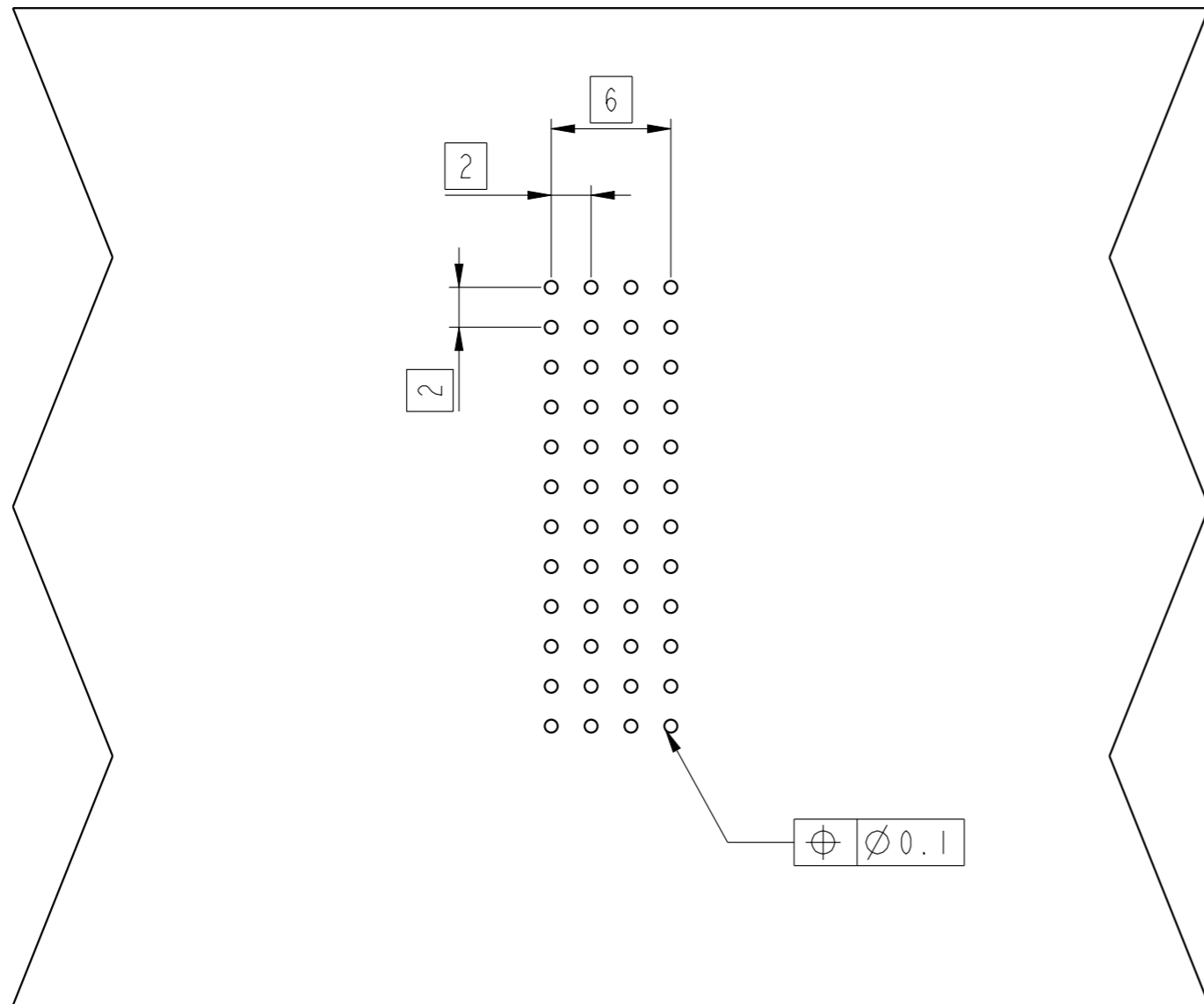

KEY		
CODE	DIMENSIONS	
	DIM A MATE	DIM B TAIL
1	5.00	4.30
2	5.75	4.30
3	6.50	4.30
4	7.25	4.30
5	5.00	13.60
6	5.75	13.60
7	6.50	13.60
8	7.25	13.60
9	5.00	17.00
10	5.75	17.00
11	6.50	17.00
12	7.25	17.00
13	8.25	4.30
14	8.25	13.60
15	8.25	17.00
19	8.00	4.30
20	8.00	13.60
21	8.00	17.00

PCB LAYOUT
 COMPONENT SIDE
 SEE PRINT 58351 FOR ADDITIONNAL
 PCB INFORMATION

Amphenol
 FCI

© 2020 Amphenol Corporation

spec ref	-	dr	Terran Huang	2010/07/09	projection	MM	size	A3	scale	1:1	
tolerance std	ISO 406 ISO 1106	eng	Rahul Mohan-M	2021/07/21			ecn no		ELX-I-41718-1		
TOLERANCES UNLESS OTHERWISE SPECIFIED		chr	-	-			product family		METRAL		rel level
surface	ISO 1302	appr	Kuriakose, San	2021/08/16	METRAL SIGNAL STRAIGHT HEADER		dwg no		85826		
linear	0.X ±0.3 0.XX ±0.10 0.XXX ±0.05	Amphenol FCI		I MODULE 4 ROW PRESS-FIT NARROW BODY		cat. no.		Product - Customer Drw		rev	N
angular	0° ±2°							sheet 2 of 8			

Creo File:ELX-WC-A3C.REV F.2020-12-21

2

3

PDS: Rev :N

STATUS:Released

Printed: Aug 17, 2021

1

2

3

4

A

A

METRAL P/N	ROW	DIM A MATE	DIM B TAIL
85826-X10LF	D	5.00	4.30
	C	5.75	4.30
	B	5.75	4.30
	A	6.50	4.30

METRAL P/N	ROW	DIM A MATE	DIM B TAIL
85826-X14LF	D	7.25	4.30
	C	6.50	4.30
	B	6.50	4.30
	A	7.25	4.30

METRAL P/N	ROW	DIM A MATE	DIM B TAIL
85826-X18LF	D	6.50	4.30
	C	5.00	4.30
	B	5.00	4.30
	A	5.00	4.30

METRAL P/N	ROW	DIM A MATE	DIM B TAIL
85826-X21LF	D	5.00	13.60
	C	5.00	13.60
	B	5.00	13.60
	A	5.00	13.60

B

B

METRAL P/N	ROW	DIM A MATE	DIM B TAIL
85826-X11LF	D	5.00	4.30
	C	5.00	4.30
	B	5.00	4.30
	A	5.00	4.30

METRAL P/N	ROW	DIM A MATE	DIM B TAIL
85826-X15LF	D	6.50	4.30
	C	6.50	4.30
	B	6.50	4.30
	A	6.50	4.30

METRAL P/N	ROW	DIM A MATE	DIM B TAIL
85826-X19LF	D	7.25	4.30
	C	7.25	4.30
	B	7.25	4.30
	A	7.25	4.30

METRAL P/N	ROW	DIM A MATE	DIM B TAIL
85826-X22LF	D	5.00	13.60
	C	5.00	13.60
	B	5.00	13.60
	A	6.50	13.60

C

C

METRAL P/N	ROW	DIM A MATE	DIM B TAIL
85826-X12LF	D	5.00	4.30
	C	5.00	4.30
	B	5.00	4.30
	A	6.50	4.30

METRAL P/N	ROW	DIM A MATE	DIM B TAIL
85826-X16LF	D	5.75	4.30
	C	5.75	4.30
	B	5.75	4.30
	A	5.75	4.30

METRAL P/N	ROW	DIM A MATE	DIM B TAIL
85826-X20LF	D	5.00	13.60
	C	5.75	13.60
	B	5.75	13.60
	A	6.50	13.60

METRAL P/N	ROW	DIM A MATE	DIM B TAIL
85826-X23LF	D	6.50	13.60
	C	5.75	13.60
	B	5.75	13.60
	A	6.50	13.60

D

D

METRAL P/N	ROW	DIM A MATE	DIM B TAIL
85826-X13LF	D	6.50	4.30
	C	5.75	4.30
	B	5.75	4.30
	A	6.50	4.30

METRAL P/N	ROW	DIM A MATE	DIM B TAIL
85826-X17LF	D	6.50	4.30
	C	5.75	4.30
	B	5.75	4.30
	A	5.00	4.30

spec ref	-	dr	Terran Huang	2010/07/09	projection	MM	size	A3	scale	1:1	
tolerance std	ISO 406 ISO 1106	eng	Rahul Mohan-M	2021/07/21		← →	ecn no	ELX-I-41718-1			
	TOLERANCES UNLESS OTHERWISE SPECIFIED	chr	-	-			rel level	Released			
surface	linear	appr	Kuriakose, San	2021/08/16	product family	METRAL	dwg no	85826		rev	N
	angular	Amphenol FCI		METRAL SIGNAL STRAIGHT HEADER							
		1 MODULE 4 ROW PRESS-FIT NARROW BODY		cat. no.		--	Product - Customer Drw		sheet 3 of 8		

1

2

3

4

1

2

3

4

A

B

C

D

A

B

C

D

METRAL P/N	ROW	DIM A MATE	DIM B TAIL
85824-X24LF	D	7.25	13.60
	C	6.50	13.60
	B	6.50	13.60
	A	7.25	13.60

METRAL P/N	ROW	DIM A MATE	DIM B TAIL
85826-X28LF	D	6.50	13.60
	C	5.00	13.60
	B	5.00	13.60
	A	5.00	13.60

METRAL P/N	ROW	DIM A MATE	DIM B TAIL
85826-X32LF	D	5.00	17.00
	C	5.00	17.00
	B	5.00	17.00
	A	6.50	17.00

METRAL P/N	ROW	DIM A MATE	DIM B TAIL
85826-X36LF	D	5.75	17.00
	C	5.75	17.00
	B	5.75	17.00
	A	5.75	17.00

METRAL P/N	ROW	DIM A MATE	DIM B TAIL
85826-X25LF	D	6.50	13.60
	C	6.50	13.60
	B	6.50	13.60
	A	6.50	13.60

METRAL P/N	ROW	DIM A MATE	DIM B TAIL
85826-X29LF	D	7.25	13.60
	C	7.25	13.60
	B	7.25	13.60
	A	7.25	13.60

METRAL P/N	ROW	DIM A MATE	DIM B TAIL
85826-X33LF	D	6.50	17.00
	C	5.75	17.00
	B	5.75	17.00
	A	6.50	17.00

METRAL P/N	ROW	DIM A MATE	DIM B TAIL
85826-X37LF	D	6.50	17.00
	C	5.75	17.00
	B	5.75	17.00
	A	5.00	17.00

METRAL P/N	ROW	DIM A MATE	DIM B TAIL
85826-X26LF	D	5.75	13.60
	C	5.75	13.60
	B	5.75	13.60
	A	5.75	13.60

METRAL P/N	ROW	DIM A MATE	DIM B TAIL
85826-X30LF	D	5.00	17.00
	C	5.75	17.00
	B	5.75	17.00
	A	6.50	17.00

METRAL P/N	ROW	DIM A MATE	DIM B TAIL
85826-X34LF	D	7.25	17.00
	C	6.50	17.00
	B	6.50	17.00
	A	7.25	17.00

METRAL P/N	ROW	DIM A MATE	DIM B TAIL
85826-X27LF	D	6.50	13.60
	C	5.75	13.60
	B	5.75	13.60
	A	5.00	13.60

METRAL P/N	ROW	DIM A MATE	DIM B TAIL
85826-X31LF	D	5.00	17.00
	C	5.00	17.00
	B	5.00	17.00
	A	5.00	17.00

METRAL P/N	ROW	DIM A MATE	DIM B TAIL
85826-X35LF	D	6.50	17.00
	C	6.50	17.00
	B	6.50	17.00
	A	6.50	17.00

Amphenol FCI

© 2020 Amphenol Corporation

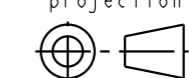
spec ref	-	dr	Terran Huang	2010/07/09	projection		size	A3	scale	1:1
tolerance std	ISO 406 ISO 1106	eng	Rahul Mohan-M	2021/07/21	product family	METRAL	ecn no	ELX-I-41718-1	rel level	Released
surface	linear	chr	-	-	METRAL SIGNAL STRAIGHT HEADER		dwg no	85826	rev	N
	angular	appr	Kuriakose, San	2021/08/16	1 MODULE 4 ROW PRESS-FIT NARROW BODY		cat. no.	--	Product - Customer Drw	sheet 4 of 8

2

3

PDS: Rev :N

STATUS:Released

Printed: Aug 17, 2021

1

2

3

4

A

B

C

D

A

B

C

D

METRAL P/N	ROW	DIM A MATE	DIM B TAIL
85826-X38LF	D	6.50	17.00
	C	5.00	17.00
	B	5.00	17.00
	A	5.00	17.00

METRAL P/N	ROW	DIM A MATE	DIM B TAIL
85826-X42LF	D	5.00	4.30
	C	5.00	4.30
	B	5.00	4.30
	A	5.75	4.30

METRAL P/N	ROW	DIM A MATE	DIM B TAIL
85826-X46LF	D	8.00	4.30
	C	6.50	4.30
	B	6.50	4.30
	A	6.50	4.30

METRAL P/N	ROW	DIM A MATE	DIM B TAIL
85826-X49LF	D	7.25	4.30
	C	6.50	4.30
	B	6.50	4.30
	A	6.50	4.30

METRAL P/N	ROW	DIM A MATE	DIM B TAIL
85826-X39LF	D	7.25	17.00
	C	7.25	17.00
	B	7.25	17.00
	A	7.25	17.00

METRAL P/N	ROW	DIM A MATE	DIM B TAIL
85826-X43	D	8.25	4.30
	C	6.50	4.30
	B	6.50	4.30
	A	6.50	4.30

METRAL P/N	ROW	DIM A MATE	DIM B TAIL
85826-X47	D	7.25	4.30
	C	7.25	4.30
	B	8.25	4.30
	A	8.25	4.30

METRAL P/N	ROW	DIM A MATE	DIM B TAIL
85826-X50LF	D	5.75	13.60
	C	5.75	13.60
	B	7.25	13.60
	A	5.75	13.60

METRAL P/N	ROW	DIM A MATE	DIM B TAIL
85826-X40LF	D	5.75	4.30
	C	5.75	4.30
	B	7.25	4.30
	A	5.75	4.30

METRAL P/N	ROW	DIM A MATE	DIM B TAIL
85826-X44LF	D	5.75	4.30
	C	6.50	4.30
	B	7.25	4.30
	A	6.50	4.30

METRAL P/N	ROW	DIM A MATE	DIM B TAIL
85826-X48LF	D	8.00	4.30
	C	8.00	4.30
	B	8.00	4.30
	A	8.00	4.30

METRAL P/N	ROW	DIM A MATE	DIM B TAIL
85826-X51LF	D	5.75	13.60
	C	5.75	13.60
	B	5.75	13.60
	A	7.25	13.60

METRAL P/N	ROW	DIM A MATE	DIM B TAIL
85826-X41LF	D	5.75	4.30
	C	5.75	4.30
	B	5.75	4.30
	A	7.25	4.30

METRAL P/N	ROW	DIM A MATE	DIM B TAIL
85826-X45LF	D	5.00	4.30
	C	5.75	4.30
	B	6.50	4.30
	A	7.25	4.30

spec ref	-	dr	Terran Huang	2010/07/09	projection	MM	size	A3	scale	1:1	
tolerance std	ISO 406 ISO 1106	eng	Rahul Mohan-M	2021/07/21		← →	ecn no	ELX-I-41718-1			
surface	linear	chr	-	-			product family	METRAL	rel level	Released	
	angular	appr	Kuriakose, San	2021/08/16	METRAL SIGNAL STRAIGHT HEADER		dwg no	85826		rev	N
					1 MODULE 4 ROW PRESS-FIT NARROW BODY						
					cat. no.	--	Product - Customer Drw		sheet 5 of 8		

Amphenol FCI

© 2020 Amphenol Corporation

1

2

3

4

1

2

3

4

A

B

C

D

A

B

C

D

METRAL P/N	ROW	DIM A MATE	DIM B TAIL
85826-X52LF	D	5.00	13.60
	C	5.00	13.60
	B	5.00	13.60
	A	5.75	13.60

METRAL P/N	ROW	DIM A MATE	DIM B TAIL
85826-X56LF	D	8.00	13.60
	C	6.50	13.60
	B	6.50	13.60
	A	6.50	13.60

METRAL P/N	ROW	DIM A MATE	DIM B TAIL
85826-X60LF	D	5.75	17.00
	C	5.75	17.00
	B	7.25	17.00
	A	5.75	17.00

METRAL P/N	ROW	DIM A MATE	DIM B TAIL
85826-X63	D	8.25	17.00
	C	6.50	17.00
	B	6.50	17.00
	A	6.50	17.00

METRAL P/N	ROW	DIM A MATE	DIM B TAIL
85826-X53	D	8.25	13.60
	C	6.50	13.60
	B	6.50	13.60
	A	6.50	13.60

METRAL P/N	ROW	DIM A MATE	DIM B TAIL
85826-X57	D	7.25	13.60
	C	7.25	13.60
	B	8.25	13.60
	A	8.25	13.60

METRAL P/N	ROW	DIM A MATE	DIM B TAIL
85826-X61LF	D	5.75	17.00
	C	5.75	17.00
	B	5.75	17.00
	A	7.25	17.00

METRAL P/N	ROW	DIM A MATE	DIM B TAIL
85826-X64LF	D	5.75	17.00
	C	6.50	17.00
	B	7.25	17.00
	A	6.50	17.00

METRAL P/N	ROW	DIM A MATE	DIM B TAIL
85826-X54LF	D	5.75	13.60
	C	6.50	13.60
	B	7.25	13.60
	A	6.50	13.60

METRAL P/N	ROW	DIM A MATE	DIM B TAIL
85826-X58LF	D	8.00	13.60
	C	8.00	13.60
	B	8.00	13.60
	A	8.00	13.60

METRAL P/N	ROW	DIM A MATE	DIM B TAIL
85826-X62LF	D	5.00	17.00
	C	5.00	17.00
	B	5.00	17.00
	A	5.75	17.00

METRAL P/N	ROW	DIM A MATE	DIM B TAIL
85826-X65LF	D	5.00	17.00
	C	5.75	17.00
	B	6.50	17.00
	A	7.25	17.00

METRAL P/N	ROW	DIM A MATE	DIM B TAIL
85826-X55LF	D	5.00	13.60
	C	5.75	13.60
	B	6.50	13.60
	A	7.25	13.60

METRAL P/N	ROW	DIM A MATE	DIM B TAIL
85826-X59LF	D	7.25	13.60
	C	6.50	13.60
	B	6.50	13.60
	A	6.50	13.60

spec ref	-	dr	Terran Huang	2010/07/09	projection	MM	size	A3	scale	1:1	
tolerance std	ISO 406 ISO 1106	eng	Rahul Mohan-M	2021/07/21		← →	ecn no	ELX-I-41718-1			
TOLERANCES UNLESS OTHERWISE SPECIFIED		chr	-	-			product family	METRAL	rel level	Released	
surface	linear	appr	Kuriakose, San	2021/08/16	METRAL SIGNAL STRAIGHT HEADER		dwg no	85826		rev	N
ISO 1302	angular				1 MODULE 4 ROW PRESS-FIT NARROW BODY		Product - Customer Drw		sheet 6 of 8		
	0.X ±0.3										
	0.XX ±0.10										
	0.XXX ±0.05										
	0° ±2°										

Amphenol FCI

© 2020 Amphenol Corporation

1

2

3

4

1

2

3

4

A

B

C

D

A

B

C

D

METRAL P/N	ROW	DIM A MATE	DIM B TAIL
85826-X66LF	D	8.00	17.00
	C	6.50	17.00
	B	6.50	17.00
	A	6.50	17.00

METRAL P/N	ROW	DIM A MATE	DIM B TAIL
85826-X70LF	D	7.25	4.30
	C	5.75	4.30
	B	5.75	4.30
	A	5.75	4.30

METRAL P/N	ROW	DIM A MATE	DIM B TAIL
85826-X74LF	D	5.75	4.30
	C	6.50	4.30
	B	6.50	4.30
	A	6.50	4.30

METRAL P/N	ROW	DIM A MATE	DIM B TAIL
85826-X81LF	D	6.50	13.60
	C	6.50	13.60
	B	5.00	13.60
	A	6.50	13.60

METRAL P/N	ROW	DIM A MATE	DIM B TAIL
85826-X67	D	7.25	17.00
	C	7.25	17.00
	B	8.25	17.00
	A	8.25	17.00

METRAL P/N	ROW	DIM A MATE	DIM B TAIL
85826-X71LF	D	6.50	4.30
	C	6.50	4.30
	B	5.00	4.30
	A	6.50	4.30

METRAL P/N	ROW	DIM A MATE	DIM B TAIL
85826-X75LF	D	5.00	4.30
	C	6.50	4.30
	B	6.50	4.30
	A	6.50	4.30

METRAL P/N	ROW	DIM A MATE	DIM B TAIL
85826-X82LF	D	5.75	13.60
	C	7.25	13.60
	B	7.25	13.60
	A	8.00	13.60

METRAL P/N	ROW	DIM A MATE	DIM B TAIL
85826-X68LF	D	8.00	17.00
	C	8.00	17.00
	B	8.00	17.00
	A	8.00	17.00

METRAL P/N	ROW	DIM A MATE	DIM B TAIL
85826-X72LF	D	5.75	4.30
	C	7.25	4.30
	B	7.25	4.30
	A	8.00	4.30

METRAL P/N	ROW	DIM A MATE	DIM B TAIL
85826-X80LF	D	7.25	13.60
	C	5.75	13.60
	B	5.75	13.60
	A	5.75	13.60

METRAL P/N	ROW	DIM A MATE	DIM B TAIL
85826-X83LF	D	5.75	13.60
	C	6.50	13.60
	B	5.75	13.60
	A	6.50	13.60

METRAL P/N	ROW	DIM A MATE	DIM B TAIL
85826-X69LF	D	7.25	17.00
	C	6.50	17.00
	B	6.50	17.00
	A	6.50	17.00

METRAL P/N	ROW	DIM A MATE	DIM B TAIL
85826-X73LF	D	5.75	4.30
	C	6.50	4.30
	B	5.75	4.30
	A	6.50	4.30

spec ref	-	dr	Terran Huang	2010/07/09	projection	MM	size	A3	scale	1:1	
tolerance std	ISO 406 ISO 1106	eng	Rahul Mohan-M	2021/07/21		←→	ecn no	ELX-I-41718-1	rel level		Released
TOLERANCES UNLESS OTHERWISE SPECIFIED		chr	-	-			product family	METRAL	rel level		Released
surface	linear	appr	Kuriakose, San	2021/08/16	METRAL SIGNAL STRAIGHT HEADER		dwg no	85826	rev	N	
ISO 1302	angular				1 MODULE 4 ROW PRESS-FIT NARROW BODY				Product - Customer Drw		
0.X	±0.3				cat. no.		--	sheet 7 of 8			
0.XX	±0.10										
0.XXX	±0.05										
0°	±2°										

Amphenol FCI

© 2020 Amphenol Corporation

1

2

3

4

