

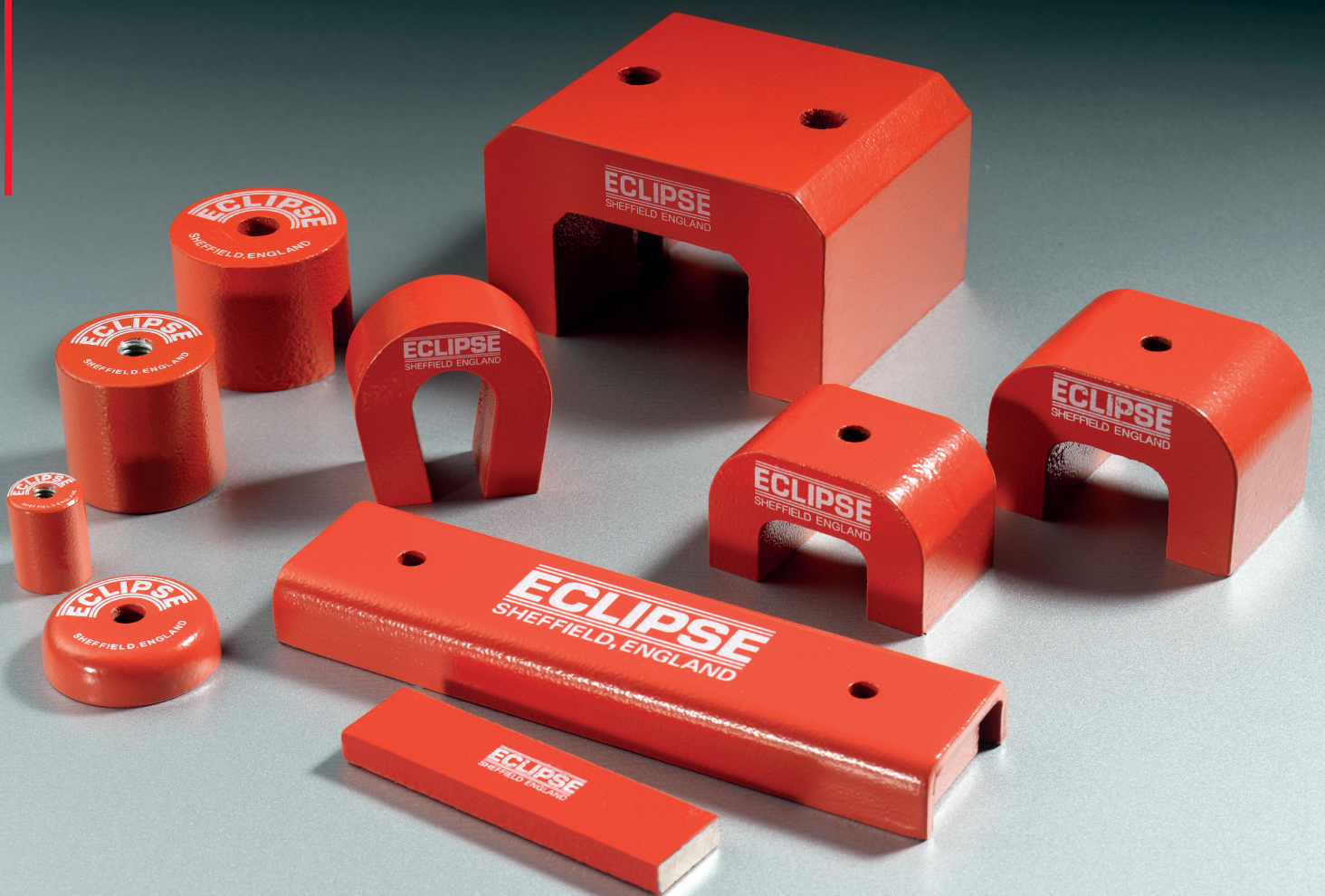

Magnetic Products

For industrial, commercial and retail applications



Magnetic Products

For Industrial, Commercial and Retail Applications

Contents

 **HERITAGE**
The world renowned range

P4-5

The world famous Eclipse branded range of magnets and pot magnets. A variety of value adding products which encompass over 100 years of magnet heritage and quality.



 **WORKSHOP**

P18-22

Innovative magnetic products for workshop, factory or DIY applications, including welding clamps, pick-up equipment, tool holders and trays.



 **UTILITY**

P6-12

A range of high performance magnet materials and assemblies for a variety of applications, from basic clamping or holding to complex design engineering projects.



 **PRECISION**

P23-25

Magnetic bases and chucks for quick, easy mounting and maintaining precision accuracy in measurement or machining applications.



 **ELECTRO**
SSS GRANTED 8+

P14-15

High quality Electromagnets for hold and release applications including access control and automation projects.



 **DISPLAY**

P26-27

Easy application marking and display products for retail, vehicle, office and warehouse applications.



 **ULTRALIFT**

P16-17

Improve steel lifting efficiency and safety with our range of easy operation magnetic lifters.



Guide to Magnetic Materials **p28**

Glossary Of Magnetic Terms **p30**

Eclipse Magnetics

Over 100 Years of Manufacturing Excellence



Serving some of the leading names in industry, including:

- Eaton Aerospace
- BAE
- Moog Aerospace
- ABB Robotics
- Tata Steel
- Sainsbury's
- Cummins
- Siemens
- Jaguar Land Rover
- Ford

Adding Value to Your Portfolio

With over 100 years' experience in the design and manufacture of high performance magnetics, we supply critical components to some of the leading names in the most demanding industries. From large automation and security projects to routine workshop applications, the end user can rest assured that Eclipse is definitely a brand to trust for quality and service.

In addition, distributors or stockists can enjoy the benefits of a prestigious range which adds financial and brand value to your portfolio.

Designing Excellence

We have a track record of producing high quality products backed by a commitment to total customer service. All manufacturing is carried out under an ISO9001 certified quality management system and we are accredited to ISO14001 environmental standards.

Worldwide Support

We offer worldwide sales and technical support through our facilities in the UK, Canada and China. In addition, we have a network of approved distribution partners throughout the world.

Most of our products are available direct from our stock locations for immediate despatch.



We are proud of our magnet heritage which began in 1914. In fact our Heritage range is globally recognized as a symbol of high quality craftsmanship and guaranteed high performance. Over the years, we have set the benchmark for magnet quality and pioneered magnet designs which have become the industry norm worldwide.

Alnico

- For material characteristics see page 28

Alnico Cylindrical Bars

- Sold in pairs
- Typical Applications: Reed switches, hall effect sensors, coin operated machines, security instruments, electrical meters, circuit boards



Product Number	Diameter mm	Length* mm	Weight / Pair kg	Gauss	Pairs / Pack
E808**	4	10	0.002	1200	5
E809**	5	10	0.003	1200	5
E810**	6	10	0.004	1200	5
E805	6	20	0.008	1200	10
E806	8	25	0.018	1200	5
E807	10	30	0.035	1200	5

*Magnetic axis **Supplied natural

Alnico Rectangular Bars

- Sold in pairs
- North pole indicated by notch
- Typical Applications: Components for reed switches, relays, hall effect sensors, oil filters, educational use, laboratory use



Product Number	Material	Length* mm	Width mm	Height mm	Weight / Pair kg	Gauss	Pairs / Pack
E842	Alnico 2	50	15	10	0.220	750	2
E843	Alnico 2	75	15	10	0.330	750	2
E844	Alnico 5	20	10	5	0.030	1100	5
E845	Alnico 5	40	12.5	5	0.040	1100	5
E846	Alnico 5	60	15	5	0.130	1100	5

*Magnetic axis

Alnico Minor

- Typical Applications: Educational use, domestic, DIY use, attracting, holding or clamping steel parts



Product Number	Length mm	Width mm	Height mm	Pole Gap mm	Weight kg	Pull Force kg	Units / Pack
E801	22.2	7.9	11.1	6.3	0.01	0.9	10

Alnico Buttons

- Typical Applications: Paint plant jigs, damping applications, relay switches, temperature sensitive devices



Product Number	Diameter mm	Height mm	Slot Size (Min-Max) mm	Hole Size mm	Weight kg	Pull Force kg	Units / Pack
E821	12.7	9.5	4.0-7.2	4.4	0.006	0.7	10
E822	19.1	12.7	5.6-8.7	4.8	0.020	1.9	10
E825	22.2	19.1	6.3-6.3	4.8	0.050	3	10
E823	25.4	15.9	5.6-8.7	4.8	0.050	3.4	10
E824	31.8	25.4	8.0-12.7	7.1	0.113	4.8	2

Alnico Pockets

- Typical Applications: Educational use, domestic/DIY attracting, holding and clamping steel parts



Product Number	Length mm	Width mm	Height mm	Width Of Gap mm	Weight kg	Pull Force kg	Units / Pack
E802	28.5	7.6	25.4	6.3	0.030	2.4	10
E803	33.3	15.9	35	7.9	0.090	4	5

Alnico Powers

- Typical Applications: Retrieval, welding/soldering fixtures, ultrasonic testing, crack detection, general attracting, clamping and holding steel parts



Product Number	Length mm	Width mm	Height mm	Width Of Gap mm	Hole Size mm	Hole Centres mm	Weight kg	Pull Force kg	Units / Pack
811	30	20	20	15	5	n/a	0.060	4.5	5
812	40	25	25	20	5	n/a	0.120	9	5
813	45	30	30	23	5	n/a	0.180	11.8	2
814	57	44.5	35	27.8	2 x 7.9	31.75	0.370	23.5	1
815	70	57.2	41.3	34.1	2 x 7.9	38.10	0.710	37	1
816	79.4	82.6	54	38.1	2 x 9.5	42.86	1.450	47	1
817	60.3	62	39.7	31.75	n/a	n/a	0.80	35	1
818	79.4	85.7	54	47.6	n/a	n/a	1.80	60	1

Alnico Shallow Pots



- Max operating temperature 450°C
- Mild steel pot
- Typical Applications: For height restricted applications, gripping, lifting, positioning jigs, soldering fixtures, general securing and fixtures

Product Number	Diameter mm	Thickness mm	Hole Size mm	Screw Head Size mm	Weight kg	Pull Force kg	Units / Pack
826	19	7.5	4.5	M3 csk	0.010	3.0	10
827	28.5	8.5	5.2	M4 csk	0.030	5.0	10
828	38.1	10.35	5.2	M4 csk	0.080	13.0	5

Alnico Deep Pots



- Max operating temperature 220°C
- Mild steel pot, aluminium spacer
- Typical Applications: Gripping, lifting, positioning jigs, soldering fixtures, general securing and fixtures

Product Number	Diameter mm	Height mm	Thread Size	Weight kg	Pull Force kg	Units / Pack
829	9.5	15	M3	0.005	1	10
830	12.7	15.9	M4	0.015	2	10
831	17.5	16	M6	0.023	2.65	10
832	20.5	19	M6	0.040	4	5
833	27	25	M6	0.085	6.1	5
834	35	30	M6	0.184	14.75	2

Ferrite

- For material characteristics see page 28

Ferrite Shallow Pots With Threaded Hole



- Max operating temperature 120°C
- Mild steel pot
- Typical Applications: For height restricted applications, light lifting, holding, securing and clamping

Product Number	Diameter mm	Thickness mm	Thread	Weight kg	Pull Force kg	Units / Pack
E780	50	10	M8	0.16	15	1
E781	80	18	M10	0.56	55	1

Ferrite Shallow Pots With Hook



- Max operating temperature 120°C
- Mild steel pot
- Removable hook
- Typical Applications: For height restricted applications, light lifting, holding, securing and clamping

Product Number	Diameter mm	Thickness mm	Thread	Weight kg	Pull Force kg	Units / Pack
E890	46	10.7	M6	0.090	6	5
E891	56	10.7	M6	0.130	16	5
E892	66	10.7	M6	0.190	25	5



With M6 tapped holes

Product Number	Diameter mm	Height mm	Fixing Stud Centres PCD M6	Central Fixing Point	Weight kg	Pull Force kg	Units / Pack
E895	66	10.7	46mm - 3 holes	M6	0.270	25	1
E896	76	12.5	46mm - 3 holes	M6	0.300	33	1
E897	100	15.5	70mm - 3 holes	M6	0.610	55	1

Ferrite Channels



- Max operating temperature 120°C
- Mild steel body

Product Number	Length mm	Width mm	Height mm	Plain Fixing Holes mm	Hole Centres mm	Weight kg	Pull Force kg	Units / Pack
E898/1	115	30	13	4.2	80	0.25	8	5
E898/2	130	30	13	4.2	90	0.3	14	5
E899	190	43	13	4.2	110	0.55	48	2



Our Utility range includes a variety of magnet materials and assemblies which are ideal for design engineering and practical projects, from basic clamping and holding to complex power generation or sensor applications.

Neodymium

- Also known as Rare Earth
- For material characteristics see page 28

Neodymium Discs

- Ideal where compact size and maximum strength are required
- Ideal for retail, display or industrial holding or mounting applications



Product Number	Diameter mm	Thickness* mm	Weight kg	Pull Force kg	Units / Pack
N835	3	1	0.0001	0.13	50
N800	3	2	0.0001	0.3	10
N836	4	1	0.0001	0.16	50
N801	4	2	0.0002	0.4	10
N802	4	3	0.0003	0.7	10
N803	4	4	0.0004	0.9	10
N837	5	1	0.0002	0.20	50
N804	5	2	0.0003	0.55	10
N805	5	3	0.0004	0.85	10
N806	5	5	0.0007	1.3	10
N838	6	1	0.0002	0.33	50
N807	6	3	0.0006	1.0	10
N808	6	4	0.0008	1.3	10
N824	6	6	0.0013	2.00	10
N839	8	1	0.0004	0.39	50
N825	8	3	0.0012	1.28	10
N809	8	4	0.0015	1.7	10
N810	8	5	0.0017	2.12	10
N840	9	1	0.0005	0.45	50
N811	9	3	0.0014	1.6	10
N841	10	1	0.0006	0.51	50
N826	10	2	0.0012	1.10	10
N812	10	3	0.0018	1.65	10
N813	10	5	0.0029	2.7	10
N842	12	1	0.0009	0.60	50
N827	12	2	0.0018	1.30	10
N828	12	3	0.0026	2.10	10
N843	15	1	0.0014	0.75	50
N814	15	3	0.0040	2.5	3
N829	15	5	0.0068	4.10	5
N815	20	3	0.0071	3.3	3
N830	20	5	0.012	5.50	5
N816	20	10	0.0236	10.5	1
N831	25	5	0.019	9.00	5

*Magnetic axis

Adhesive Backed Discs

- Easy application for magnetic closures and fixings
- Material Grade: N42
- Coating Nickel plated
- Adhesive: 3M 468 Adhesive with quick release tab
- Polarity:
North - Adhesive on south pole
South - Adhesive on north pole



Product Number	Diameter mm	Thickness mm	Polarity	Holding Force kg	Units / Pack	Product Weight Per Pack kg
N850N	6	1	North	0.30	50	11.65
N850S	6	1	South	0.30	50	11.65
N851N	8	1	North	0.40	50	18.76
N851S	8	1	South	0.40	50	18.76
N855N	9.5	0.75	North	0.35	50	22
N855S	9.5	0.75	South	0.35	50	22
N852N	10	1	North	0.50	50	30
N852S	10	1	South	0.50	50	30
N853N	12	1	North	0.65	50	41.66
N853S	12	1	South	0.65	50	41.66
N854N	15	1	North	0.80	50	67.5
N854S	15	1	South	0.80	50	67.5

Neodymium Rings

- Ideal for countersunk screw mounting
- For door closures, general fixing and attaching applications



Product Number	Diameter mm	Thickness* mm	Hole mm	Screw Head	Weight kg	Pull Force kg	Units / Pack
N832	15.4	3.25	3.3	M3	0.0044	3.5	5
N834	17.5	4	4.5	M4	0.0069	4.8	5
N833	19	7.6	4.5	M4	0.0155	8.1	5
N822	20	10	6 csk	M6	0.0214	4.7	1
N823	37	3.5	6 csk	M6	0.0275	4.9	1

*Magnetic axis

Neodymium Blocks

- Nickel plated for corrosion resistance
- Ideal for manufacturing, engineering and display projects where compact size and high strength is required



Product Number	Length mm	Width mm	Height* mm	Weight kg	Pull Force kg	Units / Pack
N817	25	10	3	0.0056	4.7	4
N818	25	10	5	0.0094	4.9	4
N819	35	10	5	0.0131	5.8	1
N820	50	20	3	0.0225	5.8	1
N821	50	50	12.5	0.2438	40.1	1

*Magnetic axis

Neodymium Shallow Pots

- High strength clamping and holding performance



Product Number	Diameter mm	Thickness* mm	Weight kg	Pull Force kg	Units / Pack
E760NEO	6	4.5	0.001	0.5	20
E761NEO	8	4.5	0.0018	1.3	20
E762NEO	10	4.5	0.0025	2.5	20
E763NEO	13	4.5	0.0045	6	20
E764NEO	16	4.5	0.0055	9.5	20
E765NEO	20	6	0.015	14	10
E766NEO	25	7	0.031	20	10
E767NEO	32	7	0.04	35	10

Neodymium Shallow Pots With Threaded Hole

- Zinc plated body
- With female threaded hole for component mounting



Product Number	Diameter mm	Thickness* mm	Total Height mm	Thread Size mm	Ferrule Outer Dia. mm	Weight kg	Pull Force kg	Units / Pack
E770NEO	6	4.5	11.5	M3	6	0.0027	0.5	20
E771NEO	8	4.5	11.5	M3	6	0.0035	1.3	20
E772NEO	10	4.5	11.5	M3	6	0.0045	2.5	20
E773NEO	13	4.5	11.5	M3	6	0.0075	6	20
E774NEO	16	4.5	11.5	M4	8	0.0132	9.5	20
E775NEO	20	6	13	M4	8	0.0165	14	10
E776NEO	25	7	14	M4	8	0.034	20	10
E777NEO	32	7	15.5	M5	10	0.048	35	5

Neodymium Shallow Pots With Countersunk Hole

- Zinc plated body
- With countersunk hole for screw fixings



Product Number	Diameter mm	Thickness* mm	Hole Size mm	Screw Head mm	Weight kg	Pull Force kg	Units / Pack
E998/NEO	10	4.5	3	M3	0.002	1.3	20
E999/NEO	13	4.5	3	M3	0.003	3	20
E1000/NEO	16	4.5	3.5	M3	0.006	7.5	20
E1001/NEO	20	6	4.5	M4	0.013	10.5	10
E1002/NEO	25	7	4.5	M4	0.024	16	10
E1003/NEO	32	7	5.5	M5	0.039	31	10
E1004/NEO	40	8	5.5	M5	0.073	50	5
E1005/NEO	48	11.5	8.5	M8	0.100	87	1

Neodymium Shallow Pots With Internal Thread

- Zinc plated body with threaded stem
- Maximum operating temperature of 80°C



Product Number	Diameter mm	Thickness* mm	Thread mm	Weight kg	Pull Force kg	Units / Pack
E1018/NEO	10	4.5	M3	0.0025	1.0	20
E1019/NEO	13	4.5	M3	0.0043	2.5	20
E1020/NEO	16	4.5	M4	0.0063	5.0	20
E1021/NEO	20	6	M4	0.011	7.0	10
E1022/NEO	25	7	M5	0.021	13.5	10
E1023/NEO	32	7	M6	0.036	25.0	10
E1024/NEO	40	8	M6	0.068	39.0	5

Neodymium Shallow Pots With Eyelet

- Zinc plated body with threaded stem
- Maximum operating temperature of 80°C



Product Number	Diameter mm	Thickness* mm	Overall Height mm	Thread mm	Weight g	Pull Force kg	Units / Pack
E1041/NEO	16	4.5	27.5	M4	9.9	8.0	20
E1042/NEO	20	6	29	M4	13	13.5	10
E1043/NEO	25	7	49	M6	29.1	18.0	10
E1044/NEO	32	7	49	M6	52	30.0	10

Neodymium Shallow Pots With Borehole

- Zinc plated body with threaded stem
- Maximum operating temperature of 80°C
- Used in point of sale



Product Number	Diameter mm	Thickness* mm	Hole In Body mm	Hole In Magnet mm	Depth mm	Weight g	Pull Force kg	Units / Pack
E1010/NEO	16	5	3.5	6.5	3.8	9.9	4	20
E1011/NEO	20	7	4.5	8	5.5	13	6	10
E1012/NEO	25	8	5.5	9	6	29.1	14	10
E1013/NEO	32	8	5.5	9	5.5	36	23	10
E1014/NEO	42	9	6.5	11	6	52	32	5

Neodymium Shallow Pots With External Thread

- Zinc plated body with threaded stem
- Maximum operating temperature of 80°C



Product Number	Diameter mm	Thickness* mm	Overall Height mm	Thread mm	Weight g	Pull Force kg	Units / Pack
E1050/NEO	10	4.5	11.5	M3	3.4	2.5	20
E1051/NEO	13	4.5	11.5	M3	3.9	6.0	20
E1052/NEO	16	4.5	13.5	M4	7.1	9.5	20
E1053/NEO	20	6	15.5	M4	14.9	14.0	10
E1054/NEO	25	7	16.5	M5	26.9	20.0	10
E1055/NEO	32	7	18.5	M6	43.9	35.0	5
E1056/NEO	40	8	20	M8	80.1	41.0	5

Neodymium Shallow Pots With Hook

- Zinc plated body with threaded stem
- Maximum operating temperature of 80°C
- Used in point of sale



Product Number	Diameter mm	Thickness* mm	Overall Height Inc. Hook mm	Thread mm	Weight g	Pull Force kg	Units / Pack
E1030/NEO	10	4.5	15	M3	4.5	0.25	20
E1031/NEO	13	4.5	15	M3	7.5	1.0	20
E1032/NEO	16	4.5	20.5	M4	13.2	0.95	20
E1033/NEO	20	6	22	M4	16.5	1.4	10
E1034/NEO	25	7	23	M4	34	2.0	10
E1035/NEO	32	7	30	M5	48	3.5	5

Neodymium Shallow Pots With Hook

- Mild steel pot painted white
- For retail and display applications
- Ideal for hanging graphics, utensils, tools etc



Product Number	Diameter mm	Thickness* mm	Total Height mm	Weight kg	Pull Force kg	Units / Pack
M19863XR	32	7	38	0.051	35	1

Neodymium Bi-Pole Deep Pots With Threaded Hole

- Aluminum pot with mild steel pole pieces



Product Number	Diameter mm	Height mm	Thread Size	Weight kg	Pull Force kg	Units / Pack
NH025	12.7	12	M5	0.01	2.5	10
NH065	16	16	M6	0.018	8.0	10
NH130	22.2	20	M6	0.04	16.0	5
NH240	25.4	25	M6	0.07	25.0	5

Neodymium Bi-Pole Deep Pots

- Brass pot
- Diameter ground to H6 tolerance
- For positioning, holding and clamping



Product Number	Diameter mm	Height mm	Weight kg	Pull Force kg	Units / Pack
E750NEO	6	20	0.004	1.0	20
E751NEO	8	20	0.007	2.5	20
E752NEO	10	20	0.011	4.5	20
E753NEO	13	20	0.019	7.0	20
E754NEO	16	20	0.029	15.0	10
E755NEO	20	25	0.057	28.0	5
E756NEO	25	35	0.128	45.0	2
E757NEO	32	40	0.228	70.0	2

Neodymium Deep Pots

- N35 grade
- Steel casing



Product Number	Diameter mm	Height mm	Thread Size	Weight kg	Pull Force mm	Units / Pack kg
E740NEO	6	20	M3	0.0040	0.6	20
E741NEO	8	20	M3	0.0075	1.2	20
E742NEO	10	20	M4	0.011	2.4	20
E743NEO	13	20	M4	0.020	6.0	20
E744NEO	16	20	M4	0.030	9.0	10
E745NEO	20	25	M6	0.058	13.5	5
E746NEO	25	35	M6	0.131	19.0	2
E747NEO	32	40	M8	0.243	34.0	2

Rubber Covered Neodymium Pots

- Strong holding force
- Prevents surface scratching

With Threaded Neck



Product Number	Diameter mm	Thickness mm	Overall Height mm	Thread Length mm	Thread Size	Holding Force kg	Units / Pack
E851	22	6	12.5	6.5	M4	5	2
E853	43	6	21	15	M6	8.5	2
E854	66	8.5	23.5	15	M8	18	2
E855	88	8.5	23.5	15	M8	42	2

With Screwed Bush

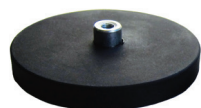

Product Number	Diameter mm	Thickness mm	Overall Height mm	Bush Diameter mm	Thread Size	Holding Force kg	Units / Pack
E851/1	22	6	11.5	8	M4	5	2
E853/1	43	6	10.5	8	M4	8.5	2
E854/1	66	8.5	15	10	M5	18	2
E855/1	88	8.5	17	12	M8	42	2

With Internal Thread



Product Number	Diameter mm	Thickness mm	Thread Size	Holding Force kg	Units / Pack
E851/2	22	6	M4	5	2
E853/2	43	6	M4	8.5	2
E854/2	66	8.5	M6	18	2
E855/2	88	8.5	M6	42	2

Alnico

• For material characteristics see page 28

Alnico Deep Pots

- Max. operating temperature: 220°C
- Mild steel pot
- Brass spacer
- Zinc plated body

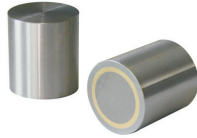

Product Number	Diameter mm	Height mm	Weight kg	Pull Force kg	Units / Pack
E790	6	20	0.004	0.2	20
E791	8	20	0.007	0.4	20
E792	10	20	0.011	0.8	20
E793	13	20	0.019	1.0	20
E794	16	20	0.029	1.8	10
E795	20	25	0.057	4.2	5
E796	25	35	0.140	8.0	2

Alnico Deep Pots

- Max. operating temperature: 220°C
- Mild steel pot
- Brass spacer
- Zinc plated body
- Diameter ground to H6 tolerance
- Ideal for press fitting into milled holes

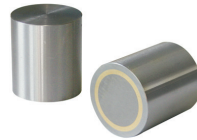

Product Number	Diameter mm	Height mm	Weight kg	Pull Force kg	Units / Pack
E730	6	10	0.002	0.2	20
E731	8	12	0.004	0.3	20
E732	10	16	0.009	0.5	20
E733	13	18	0.017	1.0	20
E734	16	20	0.029	1.5	10
E735	20	25	0.057	3.5	5
E736	25	30	0.110	8.0	5
E737	32	35	0.200	15.0	2
E738	40	45	0.420	20.0	2
E739	50	50	0.720	35.0	1

Alnico Deep Pots With Threaded Hole

- Max. operating temperature: 220°C
- Mild steel pot
- Brass spacer
- Zinc plated body

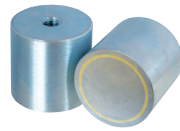

Product Number	Diameter mm	Height mm	Thread mm	Weight kg	Pull Force kg	Units / Pack
E740	6	20	M3	0.004	0.2	20
E741	8	20	M3	0.007	0.4	20
E742	10	20	M4	0.011	0.8	20
E743	13	20	M4	0.019	1.0	20
E744	16	20	M4	0.029	1.8	10
E745	20	25	M6	0.055	4.2	5
E746	25	35	M6	0.25	8.0	5
E747	32	40	M8	0.37	15.0	2
E748	45	44	M10	0.5	30.0	2

Alnico Major

- Ideal for magnetising small components
- Suitable for wave guidance applications



Product Number	Length mm	Width mm	Height mm	Pole Gap mm	Weight kg	Flux Density at Gap Centre Wb/m Gauss	Units / Pack
862	103.5	50	111	27.3	2.9	0.210 2000	1

Ferrite

- For material characteristics see page 28

Cost effective holding and clamping applications, which require durability, excellent corrosion resistance and easy release.

Ferrite Discs



Product Number	Diameter mm	Thickness* mm	Weight kg	Pull Force kg	Units / Pack
CM700-R	14	5	0.0038	0.123	10
CM701-R	20	5	0.0079	0.175	10
CM702-R	30	5	0.0177	0.262	10

Ferrite Shallow Pots With Mounting Hole

- Max. operating temperature: 120°C
- Mild steel pot
- Zinc plated body

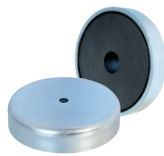

Product Number	Diameter mm	Thickness* mm	Hole In Body mm	Hole In Magnet mm	Weight kg	Pull Force kg	Units / Pack
E888	50	10	8.5	22	0.009	18	5
E889	80	18	6.5	16	0.48	54	1

Ferrite Shallow Pots With Countersunk Hole

- For screw fixing

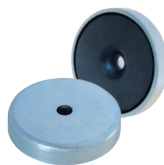

Product Number	Diameter mm	Thickness* mm	Hole Size mm	Screw Head	Weight kg	Pull Force kg	Units / Pack
E887	20	6	4.2	M4	0.09	2.7	10
E876	25	7	5.5	M5	0.016	3.6	10
E877	32	7	5.5	M5	0.027	7.2	10
E878	40	8	5.5	M5	0.053	9.0	5

Ferrite Shallow Pots With Male Thread

- Ideal for mounting components



Product Number	Diameter mm	Thickness* mm	Overall Height mm	Thread	Weight kg	Pull Force kg	Units / Pack
E720	22	7	17	M5	0.020	3.5	5
E723	32	7	22	M5	0.032	8.0	5

Ferrite Shallow Pots

- Max. operating temperature: 120°C
- Mild steel pot
- Zinc plated
- For press fit applications



Product Number	Diameter mm	Thickness* mm	Weight kg	Pull Force kg	Units / Pack
E700	10	4.5	0.002	0.4	20
E701	13	4.5	0.003	1.0	20
E702	16	4.5	0.0045	1.8	20
E703	20	6	0.010	3.0	10
E704	25	7	0.019	4.0	10
E705	32	7	0.030	8.0	10
E706	40	8	0.055	12.5	5
E707	50	10	0.100	22.0	5
E708	63	14	0.230	35.0	1
E709	80	18	0.485	60.0	1

Ferrite Pots With Hooks

- Max. operating temperature: 120°C
- Mild steel pot painted white
- Ideal for retail or general display applications
- For hanging graphics, utensils, tools etc



Product Number	Diameter mm	Height mm	Thickness mm	Thread	Weight kg	Pull Force kg	Units / Pack
E879-RB	25	8	34	M4	0.027	4.0	1
E880-RB	32	8	34	M4	0.034	8.0	1
E881-RB	36	8	34	M4	0.038	10.0	1

Ferrite Shallow Pots With Threaded Hole



- Max. operating temperature: 120°C
- Mild steel pot
- Zinc plated
- Female thread
- Ideal for mounting components with screw or bolt

Product Number	Diameter mm	Thickness mm	Overall Height mm	Thread	Weight kg	Pull Force kg	Units / Pack
E860	10	4.5	11	M3	0.003	0.4	20
E861	13	4.5	11.5	M3	0.005	1.0	20
E862	16	4.5	11.5	M3	0.006	1.8	20
E863	20	6	13	M3	0.011	3.0	10
E864	25	7	15	M4	0.022	4.0	10
E865	32	7	15	M4	0.032	8.0	5
E866	36	8	16	M4	0.045	10.0	5
E867	40	8	18	M5	0.060	12.5	5
E868	47	9	17	M4	0.090	18.0	1
E869	50	10	22	M6	0.110	22.0	1
E870	57	10.5	18.5	M4	0.145	28.0	1
E871	63	14	30	M8	0.240	35.0	1
E872	80	18	34	M10	0.520	60.0	1
E873	90	20	40	M10	0.820	70.0	1
E874	100	22	42	M12	0.940	90.0	1
E875	125	26	50	M14	1.720	130.0	1

Samarium Cobalt

- For material characteristics see page 28

For holding and clamping applications, which require high magnetic strength and excellent resistance to corrosion.

Samarium Cobalt Shallow Pots



- Max. operating temperature: 200°C
- Mild steel pot
- Zinc plated body
- For press fit applications

Product Number	Diameter mm	Thickness mm	Weight kg	Pull Force kg	Units / Pack
E760	6	4.5	0.001	0.5	20
E761	8	4.5	0.0015	1.1	20
E762	10	4.5	0.0025	2.0	20
E763	13	4.5	0.0045	4.0	20
E764	16	4.5	0.0065	6.0	20
E765	20	6	0.015	9.0	10
E766	25	7	0.022	15.0	10
E767	32	7	0.04	22.0	10

Samarium Cobalt Shallow Pots With Threaded Hole



- Max. operating temperature: 200°C
- Mild steel pot
- Zinc plated body
- Easy attachment with screw or bolt

Product Number	Diameter mm	Thickness mm	Height (Inc Thread) mm	Thread	Ferrule Outer Dia. mm	Weight kg	Pull Force kg	Units / Pack
E770	6	4.5	11.5	M3	6	0.0027	0.5	20
E771	8	4.5	11.5	M3	6	0.0036	1.1	20
E772	10	4.5	11.5	M3	6	0.0045	2.0	20
E773	13	4.5	11.5	M3	6	0.0075	4.0	20
E774	16	4.5	11.5	M4	8	0.009	6.0	20
E775	20	6	13	M4	8	0.0165	9.0	10
E776	25	7	14	M4	8	0.033	15.0	10
E777	32	7	15.5	M5	10	0.048	22.0	5

Samarium Cobalt Deep Pots



- Max. operating temperature: 200°C
- Brass pot
- Diameter ground to H6 tolerance
- Ideal for press fit installation

Product Number	Diameter mm	Thickness mm	Weight kg	Pull Force kg	Units / Pack
E750	6	20	0.004	0.8	20
E751	8	20	0.007	2.2	20
E752	10	20	0.011	4.0	20
E753	13	20	0.019	6.0	20
E754	16	20	0.029	12.5	10
E755	20	25	0.057	23.0	5
E756	25	35	0.128	40.0	2
E757	32	40	0.228	60.0	2

Customised Magnetic Solutions

If you cannot find a product in this catalogue suitable for your application, we can work with you to provide a customised solution.*

From Stage 1 To Project Completion

Many businesses are looking to add a competitive edge to their products or manufacturing processes. With our facilities and expertise we can tackle the most challenging of bespoke applications. We work closely with customers to understand their application, then to design, develop and produce a customised magnetic assembly.

Application Consultation

Our team can visit your site to understand the application and give advice.

Design & Prototyping

Using the latest software, our design team provide 3D designs, 3D FEA and trial prototypes.

Magnet Fabrication

Customised manufacture in a range of materials to customer specifications of shape, size, housings and magnetic intensity.

Magnet Stabilisation

For applications where consistent performance is critical we can ensure that magnet flux values are stabilised

Rotor Balancing

Ensures total concentricity for rotating magnet applications.

Machining Facilities

Micron accurate internal and external grinding facilities ensure that customised magnets are produced to high precision specifications.

Choice Of Materials

We can offer the complete range of magnet materials to suit different application and operating conditions.

If you have a project you would like to discuss, please contact the team on **+44 (0)114 225 0600**

*Subject to quantities

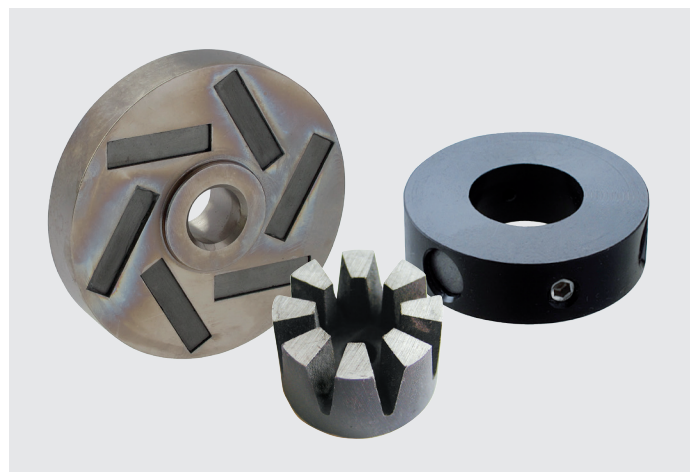
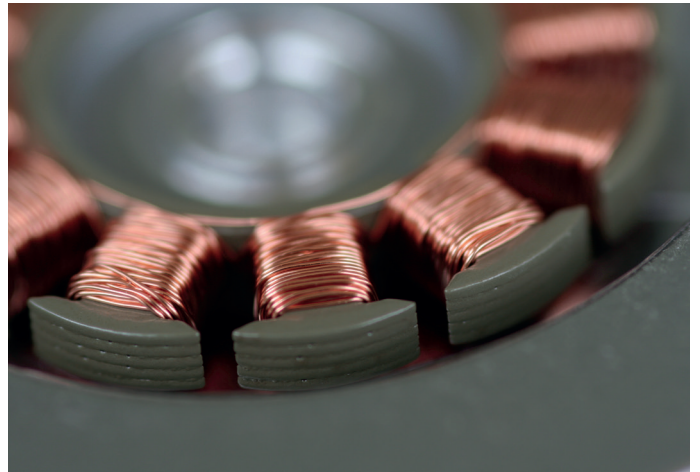



ELECTRO

A high performance range of electromagnets for design engineering projects e.g access control systems, medical devices, hold and release automation systems and machine guards.

Energise to Hold Power required to turn magnet **ON**. Power removed to turn magnet **OFF**.

- Sturdy bright nickel plated cylinder, passivated with body mounting
- High-quality permeable iron for low remanence
- Armature plates to suit

Operating Voltage	12VDC, 24VDC & 240VAC (with rectified plug connector)
Connector Options	Flying leads, two-pole connector and Hirschman connector
Mounting	Threaded holes in magnet rear face
Finish	Bright nickel plated with machined face
ED Rating	100%
IP Rating	54 (20 for the two-pole connector)



Diameter mm	Standard Operating Voltage						Air Gap mm									
	240VAC		24VDC		12VDC		0	0.09	0.18	0.27	0.36	0.59	1.00	1.59	2.00	4.00
	Product Number	Current mA	Product Number	Current mA	Product Number	Current mA	Pull Force (+/- 10%) Newtons									
20			M52180/24VDC	100	M52180/12VDC	210	53	22	9	5	3	2	1	-	-	-
25			M52172/24VDC	90	M52172/12VDC	180	150	51	22	12	8	4	2	-	-	-
30			M52173/24VDC	140	M52173/12VDC	280	280	149	80	43	26	12	5	2	2	-
40			M52174/24VDC	230	M52174/12VDC	440	550	276	144	83	57	30	14	7	5	3
50	M52175/240VA	40	M52175/24VDC	240	M52175/12VDC	470	1000	655	442	282	187	87	37	24	19	6
65	M52176/240VA	50	M52176/24VDC	340	M52176/12VDC	690	1670	1137	792	533	347	180	78	39	23	11
80			M52183/24VDC	580	M52183/12VDC	1116	2000	1560	1117	715	567	283	130	67	37	20
100			M52184/24VDC	940	M52184/12VDC	1850	3600	2790	2230	1610	1360	1340	470	260	150	60

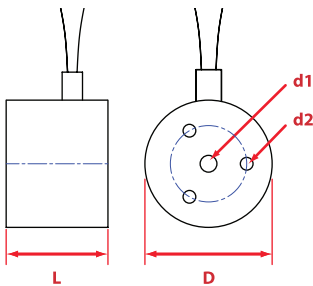

20, 25, 30mm diameter. Free leads (500mm long)
Leads: 1 red, 1 black. 0.3mm square x 500mm long)

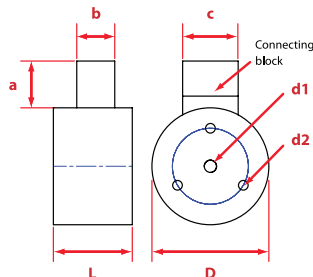

40, 50, 65, 80, 100mm diameter.
12VDC & 24VDC. Two pole connector

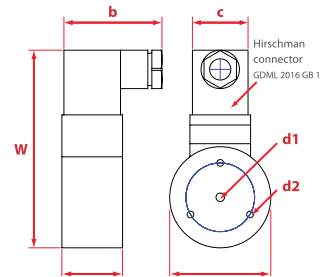

50, 65mm diameter 240VAC.
Hirschman Connector

Product Number	Dimension								PCD mm	Weight g
	D mm	L mm	W mm	A mm	B mm	C mm	D1 mm	D2 mm		
12 & 24V Units										
M52180/24VDC	20	18	-	-	-	-	M4	M3	14	36
M52172/24VDC	25	20	-	-	-	-	M4	M3	15	66
M52173/24VDC	30	24	-	-	-	-	M5	M3	18	108
M52174/24VDC	40	27	-	16	13	19	M5	M4	26	210
M52175/24VDC	50	30	-	16	13	19	M5	M4	34	364
M52176/24VDC	65	35	-	16	13	19	M8	M5	40	710
M52183/24VDC	80	38	-	16	13	19	M8	M6	50	1203
M52184/24VDC	100	43	-	16	13	19	M10	M6	75	2200
240V Units										
M52175/240VA	50	30	98	-	50	30	M5	M4	34	408
M52176/240VA	65	35	111	-	50	30	M8	M5	40	744

Energise to Release Power required to turn magnet **OFF**. Power removed to turn magnet **ON**.

- Sturdy bright nickel plated cylinder, passivated with body mounting
- High-quality permeable iron for low remanence
- Armature plates to suit



Operating Voltage	24VDC & 240VAC (with rectified plug connector)
Connector Options	Hirschman connector
Mounting	Central machined hole in rear face of magnet
Finish	Bright nickel plated with machined face
IP Rating	54
Duty Cycle	S2

		Standard Operating Voltage				Air Gap mm							
		240VAC Product Number	Current mA	24VDC Product Number	Current mA	0	0.09	0.18	0.27	0.36	0.59	1.00	1.59
Diameter mm	35	M52177/240VA	50	M52177/24VDC	240	250	91	51	32	23	17	–	–
	50	M52178/240VA	40	M52178/24VDC	350	500	317	208	151	116	73	47	28

Product Number	Dimensions						Weight g
	D mm	L mm	B mm	W mm	Connector mm	D1 mm	
M52177/24VDC	35	48	50	78	Hirschman Style	M5	352
M52178/24VDC	50	63	50	94	Hirschman Style	M5	874
M52177/240VA	35	48	50	81	Hirschman	M5	354
M52178/240VA	50	63	50	97	Hirschman	M5	880

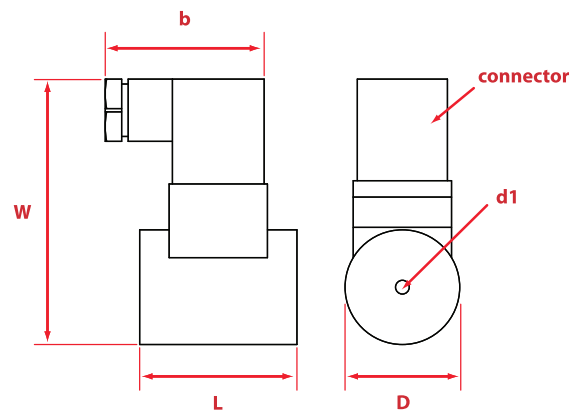

Armature Plates

- To fit both types



Product Number	Diameter mm	Height mm	Screw	To Suit Diameter mm	Weight g
M52171/25ARM	25	3	M3	20.25	15
M52171/30ARM	30	4	M4	30	30
M52171/40ARM	40	5	M4	35 / 40	50
M52171/50ARM	50	6	M4	50	100
M52171/65ARM	65	8	M5	65	210
M52171/80ARM	80	10	M6	80	400
M52171/100ARM	100	12	M10	100	740

To achieve the optimum pull force, 100% contact area must be achieved using the recommended armature plate. The force will be affected if other material specifications, thickness and surfaces are used, or if the armature fails to make positive contact over the full diameter of the face of the magnet. Where misalignment is likely to be an issue we recommend that an oversized armature plate is used to ensure 100% full contact, this however will reduce the stated pull force by approximately 10%

Our range of magnetic lifters are based on failsafe magnetic technology which provides highly efficient and totally safe lifting.

3 Safety Features

- Locking switch handle mechanism
- Unique 'Safety Shim' - Pre-test any load to ensure a 3:1 safety factor
- Locking eye mechanism - Magnet cannot be switched off while holding a load

Ultralift^{plus}+

Magnetic lifters are quicker, easier and safer to use than slings, chains, hooks and grabs, and do not mark the load.

Onboard switching and permanent magnet technology mean installation and operation could not be easier and running costs are non-existent. Access is only required to the load's top face, allowing for more efficient storage and handling.

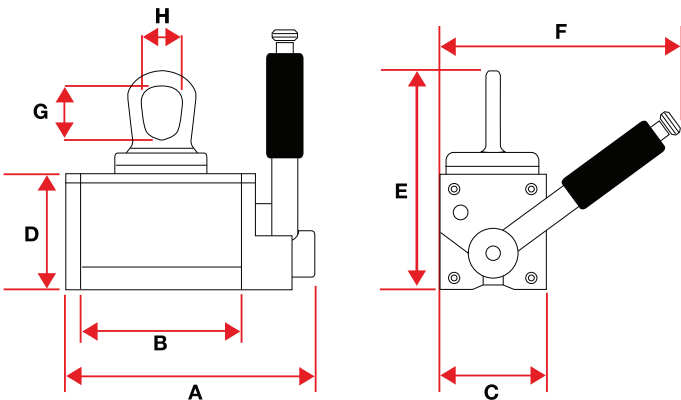

3:1 Safety Factor

The patented 'safety shim' allows pre-testing of the load to be lifted irrespective of weight, material, thickness and surface condition.



Product Number	Self Weight kg	Dimensions								Material Length Max. mm	Flat Section		Round Section	
		A mm	B mm	C mm	D mm	E mm	F mm	G mm	H mm		SWL* kg	Thickness Min. mm	SWL* kg	Diameter Max mm
UL0125+	4	155	101	69	74	138	152	34	27	1500	125	20	50	200
UL0250+	11	214	155	92	96	192	218	51	40	1500	250	25	100	300
UL0500+	27	300	224	122	128	251	266	63	49	2000	500	30	200	400
UL1000+	63	359	260	176	174	314	382	71	55	3000	1000	45	400	450
UL2000+	157	477	368	233	227	422	552	102	79	3000	2000	55	800	600

*Safe working load

UltraLift LM

Safe general-purpose lifting

- Lifts up to 2000kg (flat) 800kg (round)
- Locking switch handle safety mechanism

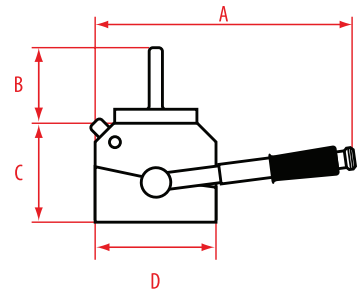

Product Number	Self Weight kg	Dimensions						Material Length Max mm	Flat Section		Round Section	
		A mm	B mm	C mm	D mm	E mm	F mm		SWL* kg	Thickness Min. mm	SWL* kg	Diameter Max mm
LM0125	4.5	150	54	62	76	110	150	125	20	50	250	
LM0250	8.5	210	76	72	90	165	150	250	25	100	300	
LM0500	17.5	281	103	88	106	225	200	500	30	200	400	
LM1000	36.5	391	113	103	136	325	300	1000	45	400	450	
LM2000	79	483	170	132	186	400	300	2000	55	800	600	

*Safe working load

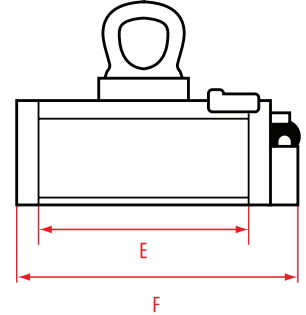

UltraLift TP

Thin Plate Lifter

- Lifts up to 400kg (flat)
- Specifically designed for the safe lifting of thin plate and pressings
- Can lift single sheets from the tops of stacks
- Locking switch handle safety mechanism

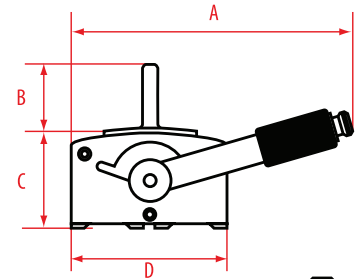

Product Number	Self Weight kg	Dimensions						Material Thickness							
		A mm	B mm	C mm	D mm	E mm	F mm	5mm		6mm		8mm		10mm	
								SWL* kg	Length mm	SWL* kg	Length mm	SWL* kg	Length mm	SWL* kg	Length mm
TP150	8	181	52	74	100	150	202	75	1500	100	1500	150	1500	200	1500
TP300	15	181	52	74	100	300	352	150	2000	200	2000	300	2000	400	2000

*Safe working load

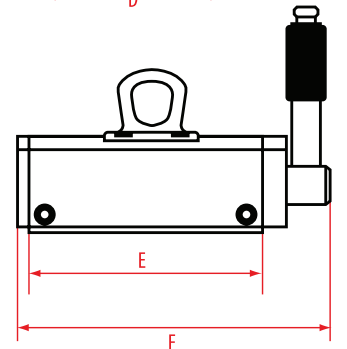

Testing Service & Spares

We test and repair all models of permanent magnetic chucks, lifters and magnetic tools.

- Free inspection and quotation
- Certificate of performance for magnetic lifters to satisfy H & S audits
- Spare parts available

For more details, call us on +44 (0)114 225 0600





WORKSHOP

Our Workshop range includes a variety of innovative magnetic devices for solving challenging problems in workshops or factories. It includes simple magnetic tools and magnetic welding clamps.

Recovery Tool

- Constructed from a ferrite magnet sandwiched between two steel plates
- Designed for recovery or retrieval, such as recovering objects from coolant tanks or vats



Product Number	Width mm	Height mm	Thickness mm	Weight kg	Pull Force kg
E936	80	101.5	36	1.4	50

Tool Rack

- Contains 2 powerful magnet bars with extruded magnetic rubber lengths, housed between two pole pieces
- Neatly secures and holds tools in the garage or workshop and knives in the kitchen



Product Number	Length mm	Height mm	Thickness mm	Weight kg
EM985-R	350	33	13	0.31

Magnetic Trays

- Magnet in base attaches the tray firmly to ferrous surfaces and holds ferrous items in the tray
- Magnet base is rubber coated to safeguard surfaces



Product Number	Diameter mm	Weight kg
E633	150	0.11
E634	102	0.10

Magnetic Tool Mat

- 3 strong ceramic magnets encapsulated in a touch PVC casing
- Widely used in production areas for keeping tools and parts within easy reach
- Magnetic both sides



Product Number	Thickness mm	Height mm	Width mm	Weight kg	Pull Force kg
EM981-R	15	150	210	0.36	5

Telescopic Pick-up Tool

- Powerful neodymium iron boron magnets are used to ensure maximum pull from a small magnetic area
- Ideal for retrieving ferrous objects that are out of reach



Product Number	Length mm	Weight kg	Pull Force kg
EM967-R	147-660	0.04	1

Flexible Pick-up Tool

- Semi-rigid, bendable pick-up tool, ideal for retrieving difficult to reach objects



Product Number	Length mm	Magnet Diameter mm	Weight kg	Pull Force kg
E600	450	6	0.11	0.5
E601	450	10	0.12	1.0
E602	520	13	0.13	1.8

Magnetic Sweeper

- Adjustable telescopic handles
- Quickly and easily clear workshop and factory floors, sports pitches and car parks of spilt items or potentially dangerous metal debris like pins, nails and metal fragments
- Handle mounted quick release mechanism



Product Number	Head Width mm	Height Including Handle kg	Pull Force kg
MSW385	385	1050	2

Swarf Wand

- Separate small parts after rumblings
- Quick release handle
- Lightweight, non-rusting shaft



Product Number	Length mm	Weight kg	Collection Capacity kg
MW400	400	0.476	6.35

Sheet Floaters

- Sheet separators use magnetic repulsion to separate sheets in a stack so they can be removed more easily
- Sold in pairs

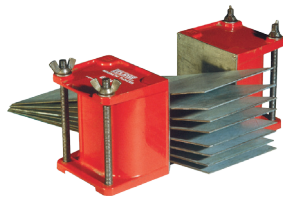

Product Number	Width mm	Height mm	Depth mm	Mounting Hole Size kg	Weight Per Pair kg
E913	73	76	65	M8	1.40
E914	92	102	76	M8	3.10
E915	113	152	89	M10	6.75

Table-top Demagnetiser

- Lightweight unit for the removal of residual magnetism from components after workholding
- CE Approved
- Max Usage: 2 mins in any 4 minute period



Product Number	Voltage	Width mm	Height mm	Depth mm	Weight kg
DA955/UK	240	150	117	87	3.83
DA955/EUR	220	150	117	87	3.83
DB956/EUR	110	150	117	87	3.83

Hand-held Pick-up Tool

- Powerful ferrite magnet attracts ferrous items to base
- Quick release handle frees attracted items
- Ideal for picking up small components, nails, bolts and spilt materials



Product Number	Length mm	Width mm	Height mm	Weight kg	Pull Force kg
E961	121	41	235	2.75	1.15

Vice Jaws

- Powerful neodymium magnet material encased in polyurethane
- Secure round and irregular workpieces without damage or distortion

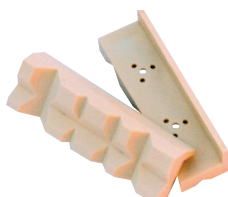

Product Number	Length mm	Height mm	Width mm	Weight Per Pair kg
EM983-R	103	32	31	0.13



Variable Welding Clamp

- Fast accurate holding of ferrous sheets and tubes for welding and assembly work
- Variable from 25° to 280°



Product Number	Length mm	Height mm	Width mm	Weight kg	Pull Force kg
E952	195	200	11	0.49	20

Heavy Duty Variable Welding Clamp

- Clamps components during welding, fabrication and assembly
- Powerful 40kg clamping force, enables larger components to be clamped with ease



Product Number	Length mm	Height mm	Width mm	Weight kg	Pull Force kg
E974	140	140	35	1.40	40

90° Fixed Welding Clamps

- Two magnetic faces in a rigid 90° angle for jiggling on sheets, pipes and tubes
- A fast and cost effective means of clamping components rigid at 90° angles during fabrication, assembly and weld preparation applications



Product Number	Length mm	Height mm	Width mm	Weight kg	Pull Force kg
E971	140	140	35	1.40	40
E972	225	225	22	2.20	75
E973	300	300	35	4.70	200

Heavy Duty Welding Clamp

- Holds workpieces at an exact 45° or 90° angle to each other
- 10kg and 15kg of magnetic pull make these ideal for a range of workshop welding and applications



Product Number	Depth mm	Height mm	Width mm	Weight kg	Pull Force kg
E954	14	82	120	0.3	10
E955	18	102	160	0.7	15

Quick Holding Clamps

- Fast and accurate holding of ferrous metals at different fixed angles
- Also suitable for retrieval applications



Product Number	Length mm	Height mm	Width mm	Weight kg	Pull Force kg
E951	100.5	65.5	12	0.3	10
E953	100.5	65.5	20	0.4	15

Mitre Clamps

- Effective and inexpensive method of clamping flat (923) or round (924) ferrous components



Product Number	Length Base Face mm	Length Top Face mm	Height mm	Width mm	Weight kg	Pull Force kg
923	156	66	45	43	1.36	100
924	184	94	45	43	1.64	68

Positioners

- 2 magnetic blocks connected by 2 non magnetic steel straps
- The blocks contain ferrite magnetic material
- Magnetic on 2 faces
- On / Off switch located at each end



Product Number	Length mm	Height mm	Width mm	Weight kg	Pull On Flat Face kg	Pull On V Face kg
922	206	63.5	76	3.17	80	80
922SU	63.5	63.5	51	1.48	80	80

Adjustable Links

- Ferrite magnetic material
- Clamp components at any angle for welding and assembly applications

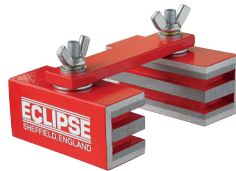

Product Number	Length mm	Height mm	Width mm	Weight kg	Pull Force kg
920SU (Single)	60	25	29	0.35	12
920 (Pair)	127	25	51	0.70	12

Adjustable Clamping Links

- Alnico magnetic material
- Clamp components at any angle for welding and assembly applications



Product Number	Length mm	Height mm	Width mm	Weight kg	Pull Force kg
920SUOT (Original Single)	60	25	25	0.32	12
920OTPR (Original Pair)	127	25	48	0.70	12

Earth Welding Clamp

- Quick and easy earthing for most steel welding operations
- Provides earthing / ground on large welding operations where croc-clip or G-Clamps cannot be easily used



Product Number	Width mm	Height mm	Length mm	Weight kg	Pull Force kg	Maximum Current amps
E946	90	64	193	1.6	25	800

Holdfasts

- Supplied with screw release handle
- Can be built into workholding, handling and assembly fixtures to provide a high clamping force and positive grip



Product Number	Diameter mm	Height mm	Fixing Holes PCD mm	Holes mm	Weight kg	Pull Force kg
E939	44.5	44.5	31.75	2 x M8	0.6	20
E940	54.0	49.2	38.1	2 x M8	1.0	40
E941	70.0	64.5	50.8	2 x M8	2.0	88
E942	101.6	74.6	69.0	3 n/a	4.7	183

Weld Holder

- Provides the welder with a powerful, rigid support on flat and round components at various angles during welding preparation applications



Product Number	Length mm	Height mm	Width mm	Weight kg	Pull Force kg
E925	108	140	108	5.67	100

Steel Plate Drag

- Used to remove steel sheets from a stack and transport sheets to and from machines
- Contains powerful permanent ferrite magnets in an aluminium housing



Product Number	Length mm	Height mm	Width mm	Weight kg	Pull Force kg
E964	118	98	38	2.8	170

Pole Indicator

- Shows the true north or true south pole of magnets
- Pocket sized
- Battery powered - Includes 4 x 1.5v batteries



Product Number	Length mm	Width mm	Thickness mm	Weight kg
MPI/100	132	22	19	0.11

Gauss Meter

- Digital hand held Gauss meter for checking magnetic flux
- Supplied with 2 probes (Transverse (TX) and Axial (AX)), Case and battery (PP3)
- Measurement units: Gauss, Tesla, Oersteds, Ampere meters



Product Number	Weight kg
GMET/1	0.5
GMET/2	0.5

Measuring Range Settings

- 1 - 1 to 3000 Gauss (0.0001 to 0.3 Tesla) Resolution - 1 Gauss
- 2 - 10 to 30,000 Gauss (0.001 to 3 Tesla) Resolution - 10 Gauss
- Auto: Automatically measures between settings 1 and 2
- +/- 15mT on/off hysteresis

Our Precision range includes magnetic bases for mounting precision measuring equipment and magnetic chucks for machining operations. Each offer quick and easy location whilst maintaining absolute accuracy.

Complete Bases & Stands

- Solid holding of precision measuring equipment
- For use in the measurement, inspection and positioning of workpieces with dial indicators
- All stands will clamp onto curved and flat surfaces, with the exception of E909 (flat only)



Product Number	Base Part Number mm	Switching Type	Fitment Part No.	Fitment Type	Hold kg
E901	E901WF	Push Button	RP991BL	Heavy duty with fine adjustment	80
E901/1	E901WF	Push Button	RP901/1	Extra large heavy duty	80
E903/CP	E900WF	Push Button	RP72CP	Light duty	30
E908M	E900WF	Push Button	RP995BL	Heavy duty	30
E905	E905WF	Lever	RP995BL	Heavy duty	80
E906	E905WF	Lever	RP991BL	Heavy duty with fine adjustment	80
E907M	E905WF	Lever	RP907S	Flexible snake arm F/A	80
E910	E905WF	Lever	RP999	Mechanical one piece	80
E909	834	Non-switchable	RP909FIT	One pillar	14

Magnetic Bases With Push Button Switch

- Eclipse Magnetics bases can be attached to any ferrous surface to provide a rigid support
- 4 magnetic faces



Product Number	Length mm	Width mm	Height mm	Hole	Weight kg	Hold kg
E900WF	48	40	52	M8	0.5	30
E901WF	64	64	76	M8	1.70	80

Magnetic Bases With Toggle Switch

- 3 magnetic faces: Top, Bottom, Back



Product Number	Length mm	Height mm	Width mm	Hole	Weight kg	Hold kg
E905WF	65	55	50	M8	1.05	80
E905WF/100	75	55	50	M8	1.20	100

Fitment Stands For Bases



Product Number	Pillar Height mm	Pillar Diameter mm	Crossbar Length mm	Crossbar Diameter mm	Screw Fixing
RP72CP	185	12.5	150	6.3	M8
RP991BL	175	12	165	10	M8
RP995BL	175	12	165	10	M8
RP901/1	300	20	200	14	M8
RP909FIT	120	6	N/A	N/A	M6

Product Number	Maximum Extension Height mm	Screw Fixing
RP907S	355	M8
RP999	295	M8



Premier Range chucks provide precision performance and durability.

Eclipse Magentics invented the first permanent magnet chuck in 1934 and we continue to set the benchmark for quality workholding with today's Premier Range.

Circular

- Unique top plate concentrates magnetic energy on to the chuck face
- The chucks can be partially magnetised to aid the correct positioning of the workpiece
- Grooved rings in the top plate assist in visual positioning to aid quick changeover
- Excellent for holding thin ring-shaped components that can be subject to radial distortion

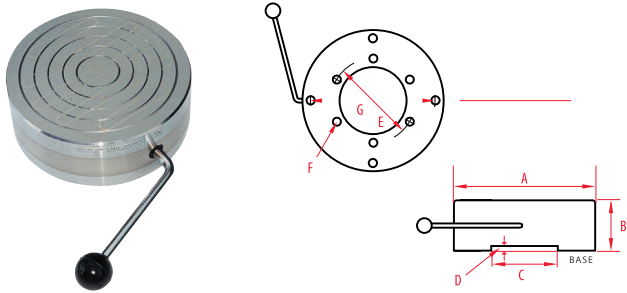

Product Number	A mm	B mm	C mm	D mm	E mm	F mm	G mm	Weight kg
AX475C/P	121	45	50.8	6.5	76.2	M6	101.6	4.23
AX651C/P	167	60	76.22	6.5	101.6	M10	139.7	9.66
AX91C/P	229	60	85.8	6.5	114.3	M10	190.5	20
AX12C/P	305	72	152.4	4.75	184.15	M12	254	45.5

Radial Pole

- Dynamically balanced to enable use at high RPM
- All metal top plate and a rugged industrial build ensures accuracy and longevity
- Through-bored (except NRC100C) allows through-flushing of coolant during machining
- Optional centre plug available

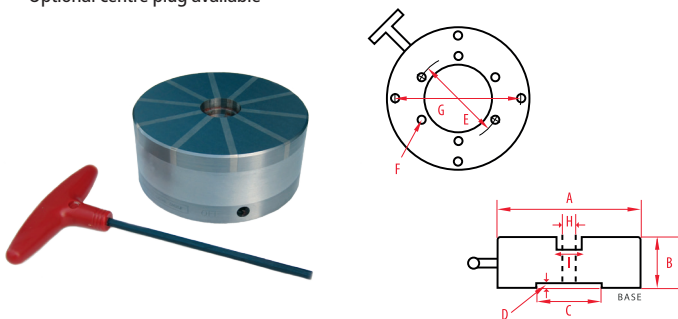

Product Number	A mm	B mm	C mm	D mm	E mm	F mm	G mm	H mm	I mm	No. Of Poles	Weight kg
NR100C	100	48	50.8	6.5	N/A	M6	76	N/A	N/A	6	3.08
NR150C	150	69	76.2	4	N/A	M10	102	32	36	10	8.79
NR225C	225	71	85.8	5	114.3	M10	190.5	50	54	14	18.5
NR300C	300	71	152.4	54.75	184.15	M12	354	62	66	18	40

Rectangular

- Unique top plate concentrates magnetic energy on to the chuck face
- The all-metal top plate is extra thick to ensure accuracy after frequent re-grinding
- Chrome plated side and end stops for packing and positioning
- The chucks can be partially magnetised to allow part positioning
- Removable, ergonomically designed handles allow easy switching



Product Number	Length mm	Height mm	Width mm	Pole Pitch	Weight kg
AX47/P	203	42	127	17.6	8.2
AX510/P	276	53	129	35	16
AXS612/P	322	63	151	32	22
AXS614/P	360	63	151	32	22
AXS618/P	451	63	151	32	36
AXM824/P	601	63	201	35	56

For enhanced precision machining, see our range of magnetic filtration products.



For longer lasting fluids, reduced waste and cost savings, visit www.magneticfiltration.co.uk

Standard Range chucks provide high performance at a competitive price

- Clamping force: 80N/cm² on test piece (steel ring 52mm outerØ. 38mmØ inner, 10mm thick)
- Brass and steel top plates
- All chucks are supplied with side and end stops, and with clamps
- Removable hexagon key handles ensure ease of operation through a 180 degree arc

Circular

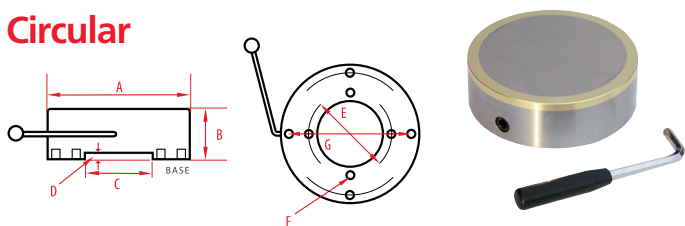

Product Number		A	B	C	D	E	F	G	Weight
Standard	Fine	mm	mm	mm	mm	mm	mm	mm	kg
ECSP100	ECFP100	100	50	50.8	6.35	76.2	M6	N/A	6
ECSP125	ECFP125	125	50	50.8	6.35	76.2	M6	101.6	9.38
ECSP160	ECFP160	160	50	76.2	6.35	101.6	M10	139.7	13.50
ECSP195	ECFP195	195	50	76.2	6.35	101.6	M10	139.7	18
ECSP255	ECFP255	255	50	85.7	6.35	114.3	M10	190.5	22.50
ECSP310	ECFP310	310	50	152.4	6.35	184.1	M12	254	32
ECSP350	ECFP350	350	50	196.8	6.35	234.9	M12	N/A	40

Chuck Blocks

- Use to extend the flux paths of a magnetic chuck with parallel poles
- Can be machined to accommodate awkward workpieces

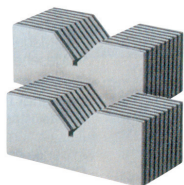

Simple Magnetic Sine Tables Short Lift

- Accuracy of sine table within (+/- 5 secs of arc)
- Pole spacing 2mm (1.5mm Steel 0.5mm Brass)
- Clamping force 80N/cm²



'V' Blocks

- 'V' blocks are ideal for holding cylindrical and complex workpieces for marking, spark erosion, grinding and measurement operations
- Can be used on its base, side or end

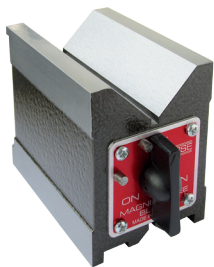

Standard Pole

Pole Spacing: 4.0mm steel - 2.0mm brass
Effectively clamps all workpiece thicknesses down to 3mm



Fine Pole

Pole Spacing: 1.5mm steel - 0.5mm brass
Ideal for small workpieces less than 3mm in height



Rectangular



Product Number		Length	Width	Height	Weight
Standard	Fine	mm	mm	mm	kg
ERSP1018	ERFP1018	180	100	50	9.5
ERSP1325	ERFP1325	255	130	50	15
ERSP1530	ERFP1530	300	150	50	20.5
ERSP1535	ERFP1535	350	150	50	23.5
ERSP1545	ERFP1545	450	150	50	30
ERSP2060	ERFP2060	600	200	50	52

Product Number	Length	Height	Width	Pole Direction	Weight
	mm	mm	mm	kg	kg
950	60	30	75	Longitudinal*	2.4
950v	50	40	100	Longitudinal*	2.4

*Along width

Product Number	Chuck	Top Plate mm		Base mm		Height At Zero mm	Weight kg
		Length	Width	Length	Width		
SSTFP1018	ERFP1018	180	100	215	115	73	12
SSTFP1325	ERFP1325	255	130	295	195	78	24
SSTFP1535	ERFP1535	350	150	390	165	89	39

Product Number	Width	Length	Height	Max diameter of workpiece		Weight
				Top 'V' mm	Bottom 'V' mm	
25 Micron Accuracy						
E934	70	101.6	95	65	22	1.98
E934MP	70	101.6	95	65	22	3.96
E935	70	80	95	65	22	3.12
E935MP	70	80	95	65	22	6.24
10 Micron Accuracy						
E933A	70	120	95	65	22	4.4
E934MPA	70	120	95	65	22	8.8
E935A	70	80	95	65	22	2.95
E935MPA	70	80	95	65	22	5.9



DISPLAY

Our Display range includes easy to apply magnetic products for a variety of display applications including retail, vehicle, office and warehouse applications.

Magnetic Tape

- Material: Strontium ferrite in thermo-plastic binder.
- Max operating temperature: 80°C
- Magnetic on 1 face only
- Can be cut with scissors



All supplied with standard acrylic adhesive. FM652, FM663, FM664, FM665 are also available with premium acrylic or foam adhesive.

Product Number	Width mm	Thickness mm	Length m	Weight kg	Pull Force g/cm ²	Pairs / Pack
EM884-R	13	0.5	1	0.027	28	1
FM660	7.5	0.75	10	0.240	44	1
FM661	12.5	0.75	10	0.390	44	1
FM662	20	0.75	10	0.630	44	1
FM652	10	1.5	30	1.7	55	1
FM663	12.7	1.5	30	2.1	55	1
FM664	20	1.5	30	3.3	55	1
FM665	25.4	1.5	30	4.2	55	1

Steel Tape

Adhesive-backed steel tape can be used with the matching width adhesive backed magnetic tape to provide temporary and semi-permanent fixings.

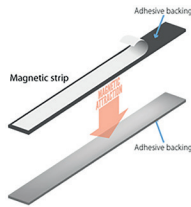

Supplied with standard acrylic adhesive.

Product Number	Matching Magnetic Tape mm	Width mm	Thickness mm	Roll Length m	Weight kg	Units / Pack
FM667	FM663	13	0.2	30	0.8	1
FM668	FM664	20	0.2	30	1.2	1
FM669	FM665	25	0.2	30	1.5	1

Magnetic Extrusion

- Material: Strontium ferrite in thermo-plastic binder
- Max operating temperature: 80°C
- Magnetic on 1 face only
- Forms a strong bond when paired with itself



Please contact us if you require custom extruded profiles

Product Number	Width mm	Thickness mm	Length m	Weight kg	Pull Force g/cm ²	Pairs / Pack
EM888-R (Pairs) *	9.5	3.6	0.15	0.021	65	10 Pairs
EM880-R	9.5	3.6	2	0.026	65	1
FM670	9.5	3.6	10	1.44	65	1
FM671	11	4.6	10	2.07	65	1
FM672	15	6.4	10	3.64	65	1

*Adhesive Backed

Magnetic Sheet

- Material: Strontium ferrite in thermo-plastic binder
- Max operating temperature: 80°C
- Magnetic on 1 face only
- UV Coating for cleaner handling.
- Flexible and impact resilient but can be easily cut with scissors
- Regular shapes can be cut using inexpensive dies



Available with plain, white gloss or standard acrylic adhesive backing. Coloured and dry wipe finishes available.

Please contact us for details.

Product Number	Thickness mm	Width mm	Roll Length m	Weight kg	Pull Force g/cm ²	Finish
060510A2	0.5	620	30	35	28	Plain
060710A2	0.75	620	30	53	44	Plain
060524A2	0.6	620	30	43	28	Gloss Vinyl White
060724A2	0.85	620	30	60	44	Gloss Vinyl White
060724D2	0.85	620	15	30	44	Gloss Vinyl White
060724X5	0.6	1000	10	23	28	Gloss Vinyl White
060724X4	0.85	1000	10	33	44	Gloss Vinyl White
060711A2	0.8	620	30	60	44	Adhesive Backed

Product Number	Thickness mm	Width mm	Tile Length m	Weight kg	Pull Force g/cm ²	Finish	Units / pack
FM650	0.75	150	0.15	0.071	44	Adhesive	5

Labelling

3 ways to make your own custom magnetic labels:

- Print with laser printer or inkjet on to matt or gloss magnetic paper
- Apply self adhesive magnetic sheet to the back of labels, signs and graphics
- Write on dry-wipe flexible magnetic sheet



All materials are easily cut with scissors

Product Number	Description	Application	Size	Thickness mm	Finish	Units / Pack
FM651	Magnetic paper	Laser / Inkjet Printing	A4	0.25	White Matt	10
060511D1	Self adhesive magnetic sheet	Application to existing card / label	Business Card (85x55)	0.6	Adhesive Backed	25
060711Y6	Self adhesive magnetic sheet	Application to existing card / label	A4	0.8	Adhesive Backed	10
060510U14	Dry wipe magnetic sheet	Dry-wipe marker	A4	0.6	White Dry-Wipe	10

Label Holders

- Temporary / permanent signage, identification
- Can be used on steel racking, cabinets, shelving or any magnetically receptive surface
- Complete with magnetic rubber, white card and cover



Product Number	Width mm	Height mm	Units / Pack	Weight kg
FM676/B	100	25	50	1
FM677/B	100	30	50	1
FM683	150	35	5	0.125

Product Number	Roll Length m	Height mm	Units / Pack	Weight kg
FM674C	50	15	1	7
FM676C	50	25	1	7
FM677C	50	30	1	7

Racking Strip & Bay Markers

- Sticks to all steel racking
- Dry-wipe surface - write on, wipe off
- Supplied in 10 metre rolls
- Thickness: 0.5mm



Width mm	Yellow	Blue	Red	White	Green
20	060510U8/Y	060510U8/B	060510U8/R	060510U8/W	060510U8/G
30	060510U9/Y	060510U9/B	060510U9/R	060510U9/W	060510U9/G
50	060510U10/Y	060510U10/B	060510U10/R	060510U10/W	060510U10/G
70	060510U11/Y	060510U11/B	060510U11/R	060510U11/W	060510U11/G
90	060510U12/Y	060510U12/B	060510U12/R	060510U12/W	060510U12/G

Marker Magnets

- Magnet material in a coloured plastic shell
- Ideal for filing cabinets, fridge doors and noticeboards



Diameter mm	Yellow	Blue	Red	White	Green	Black	Orange
20	RM765/Y	RM765/BLU	RM765/R	RM765/W	RM765/G	RM765/BLK	RM765/O
30	RM768/Y	RM768/BLU	RM768/R	RM768/W	RM768/G	RM768/BLK	RM768/O

Hook Magnets

- Mild steel pot
- Ideal for hanging graphics, utensils and other items
- See pages 8 and 11 for more information



Guide To Magnet Materials

When choosing a magnet material for an application you should take the following factors into consideration:

- Flux requirement of the application
- Maximum operating temperature
- Likely exposure to corrosive conditions
- Magnetic stability
- Size and weight limitations

What strength/flux of magnet do you need?

This table shows the comparative magnetic strengths of the same volume of the four main magnet materials in terms of their maximum energy products (BHmax) in CGS or SI units and their typical pole face flux densities.

Magnet Material	Max Energy Product: CGS	Max Energy Product: SI	Flux Density
Ferrite	3.3 MGOe	26 KJ/m ³	1000 Gauss
Alnico	5.2 MGOe	42 KJ/m ³	1300 Gauss
Samarium Cobalt	26 MGOe	208 KJ/m ³	3500 Gauss
Neodymium	35 MGOe	279 KJ/m ³	4500 Gauss

Neodymium is the most powerful magnet material available. It is ideal for applications where high flux density is required or where space is at a premium.

What temperature will the magnet be operating in?

In most applications, operating temperature is not a consideration but extreme temperatures will have an effect on the magnetic performance.

Magnet Material	Max Working Temperature °C	Effects of Sub Zero Temperature °C	Reversible Effect Of Temp: 20°C - 150°C
Ferrite	250	Large irreversible losses below -60°C	-0.19% per °C
Alnico	550	Permanent losses no more than 10% expected down to -269°C	-0.02% per °C
Samarium Cobalt	300	Minimal losses down to -269°C	-0.003% per °C
Neodymium	80*	No irreversible losses down to -196°C	-0.12% per °C

*N35 grade. Other grades available up to 230°C

Each material has different temperature characteristics and these must be reviewed to ensure that the correct material is used for the application. Using the wrong material could lead to loss in magnetic performance.

Other Factors To Consider

Corrosion

Another potential cause of performance loss is a breakdown of the magnet's composition due to corrosive environmental effects. This table shows relative corrosive resistance for each material when uncoated. As neodymium's corrosive resistance is poor it is usually sold with a protective coating, normally either nickel or zinc.

Magnet Material	Corrosion Resistance Uncoated	Resistance To Demagnetisation
Ferrite	Excellent	High
Alnico	Fair	Low
Samarium Cobalt	Excellent	Very High
Neodymium	Poor	Very High

External Demagnetising Fields / Magnet Stability

Temperature has the greatest effect on magnet stability but high external magnetic fields can influence performance. This table shows the relative demagnetising effect on each material.

Magnetic field flowing across an air gap?

Single pole operation (bar, block, disc and ring magnet)

When a depth of field is required for attracting, switching or actuating across an air gap, use a single piece of magnet.

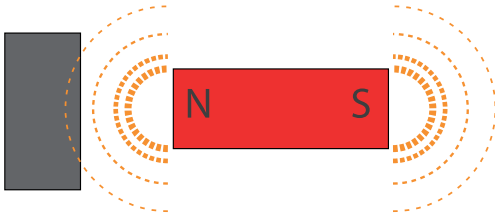

Single pole operation magnet flux crosses a gap but has a diminishing strength field.

Pot Magnets

Both north and south pole are on one face of the magnet, similar to button and horseshoe magnets.

The magnetic material is encased inside a steel pot. The pot is part of the magnetic circuit. The poles are concentric.

The depth of the magnetic field is shallower than that of magnets with poles further apart, e.g. horseshoe magnets, but grip in intimate contact is generally superior.

Maximum operating temperature of pots is lower than the magnet material used because of the different thermal expansion rates of the material and the pot. Exposure to temperatures higher than the recommended maximum can cause units to come apart.

Other Features

- No stray flux as magnetism is retained in a closed circuit
- Pot screens magnet material from demagnetising effects
- Pot is machinable
- Can be inserted into steel without adverse effects (not the case with unscreened magnets)

Clamping, holding or lifting?

Two pole operation (Horseshoe, button or pot magnet)

Two pole or multi-pole magnets are designed for holding, clamping or lifting when in direct contact with a ferro-magnetic surface.

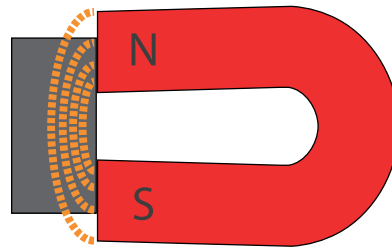

Two pole operation magnet flux does not travel as far but is stronger

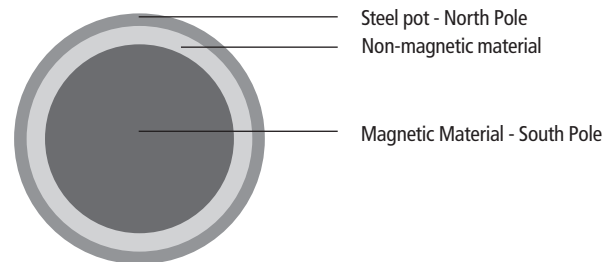

Button magnet



Horseshoe Magnet

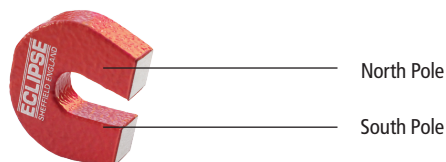

Please note, this guide provides general information only.

For specific information on bespoke products or applications please contact us on +44 (0)114 225 0600

Glossary of Magnetic Terms

Air Gap

A non-magnetic discontinuity in a magnetic circuit (i.e. the distance between two magnetic poles), this gap often includes other materials such as brass, aluminium or paint.

Anisotropic Magnet

A magnet which has a preferred direction of orientation so that the magnetic characteristics are optimum in one preferred direction.

Closed Circuit

This exists when the flux path external to the permanent magnet is confined within high permeability materials which contain the magnet circuit.

Coercive Force, H_c

The demagnetising force necessary to reduce observed induction B to zero after the magnet has been brought to saturation. Coercive force is measured in Oersteds or more recently A/m and kA/m.

Curie Temperature, T_c

The temperature at which a material loses its permanent magnetic properties completely and is no longer able to hold magnetism.

Demagnetisation Curve

The second/left quadrant of the hysteresis loop, generally describing the behaviour of magnetic characteristics in actual use. Also known as the B-H curve.

Ferromagnetic Material

A material whose permeability is very much larger than one, and which exhibits hysteresis magnetising and demagnetising characteristics. The greater the flux carrying potential, the bigger the value i.e. one to several thousands.

Flux

Magnetic flux is the condition existing in a medium subjected to a magnetising force. This value is quantified by E.M.F (Electromotive Force). This measurement of force in cgs units is a Maxwell.

Fringing Fields

Leakage flux particularly associated with edge effects and leakage patterns in a magnetic circuit.

Gauss

Lines of magnetic flux per square centimetre. Gauss is measured in cgs units, Maxwell Lines and Webers per square metre or Tesla in the SI system.

Hysteresis Loop

A closed curve calculated by plotting corresponding values of magnetic induction: B on the abscissa against magnetising force H .

Induction, B

This is the magnetic flux per unit area of section in the applied magnetic direction of flux. This is measured in Gauss.

Intrinsic Coercive Force

This is a measure of the resistance of the magnet material to a demagnetising force. Permanent magnets with high intrinsic coercivity values are usually classified as 'hard' permanent magnets.

Intrinsic coercive force indicates magnetic stability at high temperatures. Also see Stabilisation.

Irreversible Loss

This is the partial demagnetisation of a magnet material when introduced to external factors such as high/low temperatures and demagnetising fields. Losses can only be rectified by remagnetisation. However, magnets can be stabilised to prevent the variation of performance caused by irreversible losses.

Isotropic Magnet

A magnet material which does not have a preferred direction of magnetic orientation and therefore can be magnetised in any direction without the loss of magnetic characteristics.

Knee Of The Demagnetisation Curve

The point at which the B-H curve ceases to be linear. If the operating point of the magnet falls below the knee, the magnet will not be able to recover full magnetic potential without the application of a magnetising force.

Leakage Flux

This is the loss of magnetic flux which occurs through leakage caused by saturation or air gaps introduced into the magnetic circuit. This induces a loss of efficiency in the circuit which cannot be recovered.

Length of Air Gap, L_g

Indicates the length of the central flux path across an air gap.

Load Line

A line drawn from the origin of the demagnetisation curve with a slope. The intersection of the $-B/H$ curve and slope represents the operating point of the magnet. Also see permeance coefficient, PC.

Magnetic Circuit

An assembly consisting of some or all of the following: Permanent magnets, ferromagnetic conduction elements, air gaps and electric currents.

Magnetic Flux

The total magnetic induction over a given area.

Magnetising Force, H

The magnetomotive force per unit length at any point in a magnetic circuit. This is measured in Oersteds.

Magnetomotive Force, F

This is the potential magnetic difference between any two points.

Maximum Energy Product, BH_{Max}

There is a point at the hysteresis loop at which the product of the magnetising force H and induction B reaches a maximum. This maximum value is called the Maximum Energy Product and is measured in Mega Gauss Oersted, MGOe.

Oersted, Oe

A unit of magnetising force (cgs). This is equivalent to Ampere Turns per Inch (S.I)

Permeance Coefficient, P_c

Ratio of the magnetic induction to self demagnetising force. This is also known as the 'load line' or operating point of the magnet.

Pull Gap

Usually illustrated in graph form, these curves are a representation of the relationship between the attractive force exerted by a magnet on a soft magnetic work-piece and the distance between them.

Pull Gap curve diagrams are useful when selecting a magnet for a particular tractive or holding application.

Remenance

Remenance is the magnetic induction which remains in a magnetic circuit after the removal of an applied magnetising force. If there is an air gap in the circuit, the remenance will be less than the residual induction B_r .

Residual Induction, B_r

This represents the maximum flux output from a given magnet material measured at the point where the hysteresis loop crosses the B axis at zero magnetising force.

Return Path

A magnetic circuit which provides a low reluctance path for the magnetic flux. Reversible Temperature Coefficient A measure of the reversible changes in flux caused by temperature variations.

Saturation

This is the condition whereby a magnet or ferromagnetic material has reached a maximum value and an increase in the appliance of magnetising force produces no increase in induction i.e. saturation flux densities for steels range from 16,000 to 20,000 Gauss.

Stabilisation

The process where a magnet is exposed to demagnetising influences expected to be encountered in operation. The exposure to these demagnetising influences such as high or low temperatures or external magnetic fields prevents irreversible losses during operation.



Eclipse Magnetics Worldwide

Europe

Atlas Way
Sheffield
S4 7QQ
England

T +44 (0)114 225 0600
F +44 (0)114 225 0610
sales@eclipsemagnetics.com

Americas

442 Millen Road, Unit 9,
Stoney Creek
Ontario, L8E 6H2,
Canada

T +1 905-664-5585
F +1 905-664-7090
sales@eclipsetoolsinc.com

China

No. 168 Chengjian Road
Minhang District
Shanghai
PR China

T +86 21 6434 8600 *150
F +86 21 6434 6488
szhou@eclipsemagnetics.com

Representative:

www.eclipsemagnetics.com

Eclipse Magnetics Ltd

Atlas Way, Atlas North, Sheffield, S4 7QQ, England.

T +44 (0)114 225 0600 **F** +44 (0)114 225 0610 **Q** www.eclipsemagnetics.com **E** info@eclipsemagnetics.com

While every effort has been made to ensure the accuracy of the information within this publication, please note that specifications may change without notice.