

DO NOT SCALE FROM THIS PRINT

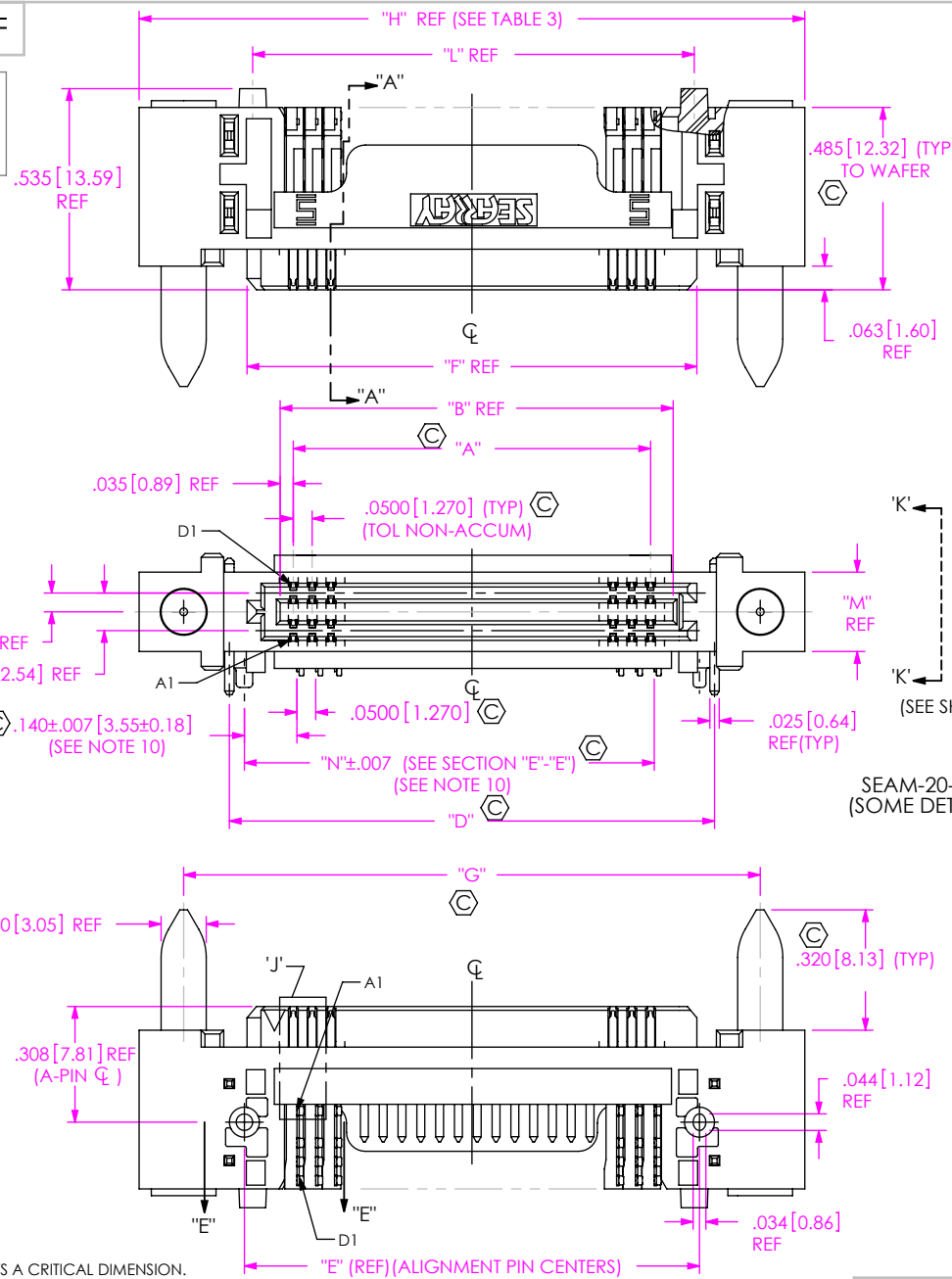

SEAM-XX-XX-X-XX-X-RA-XX-X-XR

No. OF POSITIONS
-20, -30, -40, -50 (PER ROW)

LEAD STYLE
-01

PLATING SPECIFICATION
-S: SELECTIVE GOLD, MATTE TIN ON TAILS (USE SUB-IM-T-1M64-01-XX-S-X)
-L: LIGHT SELECTIVE GOLD, MATTE TIN ON TAILS (USE SUB-IM-T-1M64-XX-L-X)

No. OF ROWS
-04, -06, *-08, *-10 (* = SEE NOTE 9)

TAPE & REEL (SEE NOTES 7 & 15)
-TR: TAPE & REEL
-FR: FULL REEL QTY TAPE & REEL

PICK & PLACE OPTION
-K: POLYAMIDE FILM (FIG 6, SHT 4)

OPTIONS
-GP: GUIDE POST (SEE NOTE 12)

RIGHT ANGLE
-RA

SOLDER COMPOSITION & STYLE (C)
-1: 63% TIN / 37% LEAD CHARGE TAIL (USE SUB-IM-T-1M64-XX-XX-1)
-2: 95.5% TIN / 3.8 SILVER / 0.7% COPPER LEAD FREE CHARGE TAIL (USE SUB-IM-T-1M64-XX-XX-2)

TABLE 7

STYLE	No. OF ROWS	"M"	
WITH -GP OPTION	-04	0.211	[5.36]
	-06	0.311	[7.90]
	-08	0.411	[10.44]
	-10	0.511	[12.98]

TABLE 3

STYLE	No. OF POS PER ROW	"G"		"H"	
WITH -GP OPTION	-20	1.533	[38.94]	1.770	[44.96]
	-30	2.033	[51.64]	2.270	[57.66]
	-40	2.533	[64.34]	2.770	[70.36]
	-50	3.033	[77.04]	3.270	[83.06]
WITHOUT -GP OPTION	-20	N/A		1.440	[36.58]
	-30	N/A		1.940	[49.28]
	-40	N/A		2.440	[61.98]
	-50	N/A		2.940	[74.68]

FIG 1
SEAM-20-01-X-04-X-RA-GP SHOWN (SOME DETAIL OMITTED FOR CLARITY)

TABLE 2

No. OF ROWS	"BODY CALLOUT"	"TERMINAL WAFER"	"WELD TAB"	"C"	
-04	SEAM-XX-01-RA-04-XX	SUB-IM-T-1M64-01-04-X-X	WT-28-01-T	0.205	[5.21]
-06	SEAM-XX-01-RA-06-XX	SUB-IM-T-1M64-01-06-X-X	WT-28-02-T	0.305	[7.75]
-08	SEAM-XX-01-RA-08-XX	SUB-IM-T-1M64-01-08-X-X	WT-83-01-T	0.405	[10.29]
-10	SEAM-XX-01-RA-10-XX	SUB-IM-T-1M64-01-10-X-X	WT-83-02-T	0.505	[12.83]

TABLE 1

No. OF POS. PER ROW	"A"	"B"	"D"	"E"	"F"	"N"
-20	0.950 [24.13]	1.045 [26.54]	1.290 [32.77]	1.210 [30.73]	1.196 [30.38]	1.090 [27.69]
-30	1.450 [36.83]	1.545 [39.24]	1.790 [45.47]	1.710 [43.43]	1.696 [43.08]	1.590 [40.39]
-40	1.950 [49.53]	2.045 [51.94]	2.290 [58.17]	2.210 [56.13]	2.196 [55.78]	2.090 [53.09]
-50	2.450 [62.23]	2.545 [64.64]	2.790 [70.87]	2.710 [68.83]	2.696 [68.48]	2.590 [65.79]

TABLE 8

No. OF ROWS	"L"				"BACK STRAP"
	20 POS	30 POS	40 POS	50 POS	
-04	1.174 [29.82]	1.674 [42.52]	2.174 [55.22]	2.674 [67.92]	N/A
-06, -08, -10	N/A	N/A	N/A	N/A	SEAX-RA-BS-XX-01

- NOTES:
- ⊕ REPRESENTS A CRITICAL DIMENSION.
 - MINIMUM PUSH-OUT FORCE: .50 LBS [2.2N].
 - INSPECT DIMENSION AT FIRST POSITION WAFER LOCATION ONLY, FIRST AND LAST PIN.
 - NOTE DELETED.
 - NOTE DELETED.
 - NOTE DELETED.
 - ATTACH LABEL "SEAX-0001" TO EACH TAPE & REEL PACKAGE.
 - NOTE DELETED.
 - ON -08 & -10 ROW ASSEMBLIES, SEE FIG 8, SHEET 5 FOR CAT FIXTURE VIEW
 - CHECK DIMENSION ON FIRST AND LAST ROW OF TAILS.
 - A 20-30°C TEMPERATURE DIFFERENCE MAY EXIST BETWEEN THIS HIGH-DENSITY COMPONENT AND THE BOARD SURFACE DURING REFLOW. SAMTEC RECOMMENDS A THERMAL STUDY BE PERFORMED TO UNDERSTAND THE TEMPERATURE GRADIENTS YOU MAY EXPERIENCE.
 - MINIMUM GUIDE POST PUSH-OUT FORCE: 4 LBS [17.8N].
 - SOME RELAXATION/WARPING OF THE BACKSTRAP IS ACCEPTABLE AFTER PROCESSING.
 - SEE SHEET 5 FOR PROCESSING INFORMATION.
 - ORDERS WILL BE PACKAGED ACCORDING TO THE SAMTEC PACKAGING EFFICIENCY STANDARDS (SPES) FOUND ON WWW.SAMTEC.COM.

UNLESS OTHERWISE SPECIFIED, DIMENSIONS ARE IN INCHES.

TOLERANCES ARE:
DECIMALS ANGLES
.XX: ±.01 [0.3]
.XXX: ±.005 [0.13]
.XXXX: ±.0020 [0.051]

PROPRIETARY NOTE
THIS DOCUMENT CONTAINS CONFIDENTIAL AND PROPRIETARY INFORMATION AND ALL DESIGN, MANUFACTURING, REPRODUCTION, USE, PATENT RIGHTS AND SALES RIGHTS ARE EXPRESSLY RESERVED BY SAMTEC, INC. THIS DOCUMENT SHALL NOT BE DISCLOSED, IN WHOLE OR PART, TO ANY UNAUTHORIZED PERSON OR ENTITY NOR REPRODUCED, TRANSFERRED OR INCORPORATED IN ANY OTHER PROJECT IN ANY MANNER WITHOUT THE EXPRESS WRITTEN CONSENT OF SAMTEC, INC.

MATERIAL: DO NOT SCALE DRAWING SHEET SCALE: 2:1

INSULATOR: LCP, COLOR: BLACK, UL 94 V-0
CONTACT: COPPER ALLOY .006 THICK

DESCRIPTION:
SEAM-RA ASSEMBLY
DWG. NO.
SEAM-XX-XX-X-XX-X-RA-XX-X-XR
BY: R MUSSER 06/27/2008 SHEET 1 OF 5

520 PARK EAST BLVD, NEW ALBANY, IN 47150
PHONE: 812-944-6733 FAX: 812-948-5047
e-Mail: info@SAMTEC.com code 55322

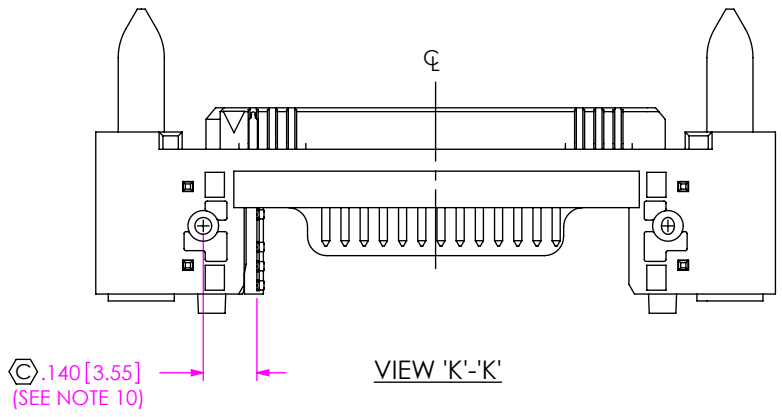
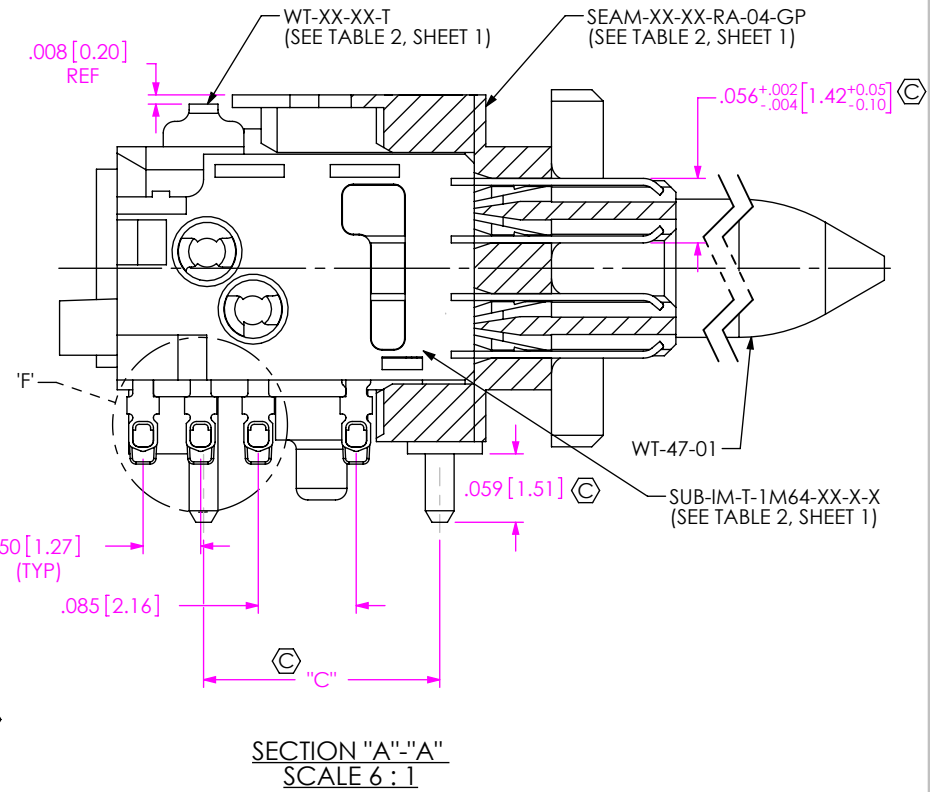
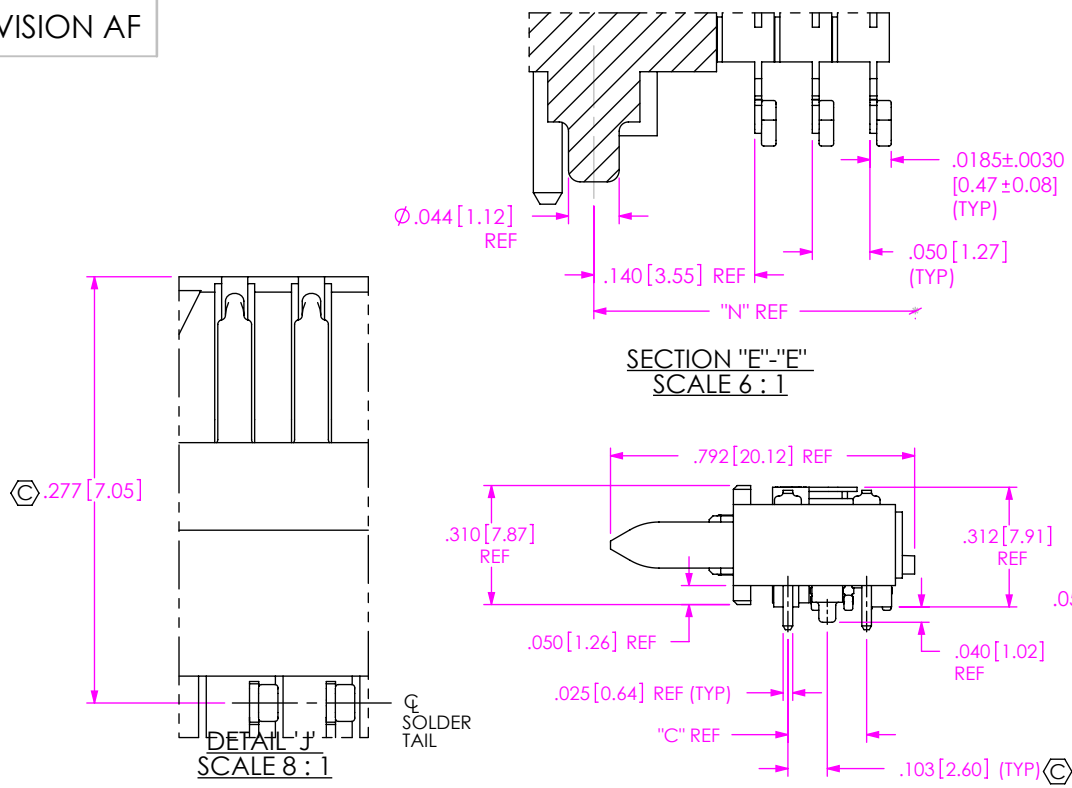

IN-PROCESS VIEW
(SEAM-20-01-X-04-X-RA-GP)
(FILL FIRST WAFER TO DIMENSION SHOWN)

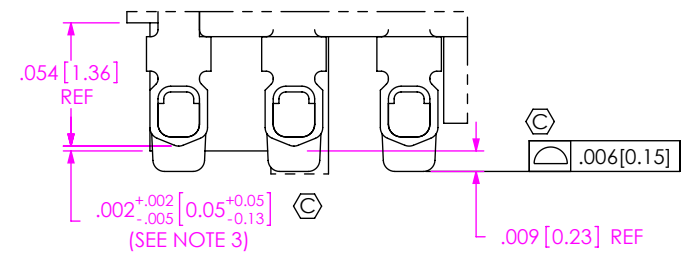

PROPRIETARY NOTE
THIS DOCUMENT CONTAINS CONFIDENTIAL AND PROPRIETARY INFORMATION AND ALL DESIGN, MANUFACTURING, REPRODUCTION, USE, PATENT RIGHTS AND SALES RIGHTS ARE EXPRESSLY RESERVED BY SAMTEC, INC. THIS DOCUMENT SHALL NOT BE DISCLOSED, IN WHOLE OR PART, TO ANY UNAUTHORIZED PERSON OR ENTITY NOR REPRODUCED, TRANSFERRED OR INCORPORATED IN ANY OTHER PROJECT IN ANY MANNER WITHOUT THE EXPRESS WRITTEN CONSENT OF SAMTEC, INC.

DO NOT SCALE DRAWING
SHEET SCALE: 2:1



520 PARK EAST BLVD, NEW ALBANY, IN 47150
PHONE: 812-944-6733 FAX: 812-948-5047
e-Mail info@SAMTEC.com code 55322

DESCRIPTION:
SEAM-RA ASSEMBLY

DWG. NO.
SEAM-XX-XX-X-XX-X-RA-XX-X-XR

BY: R MUSSER 06/27/2008 SHEET 2 OF 5

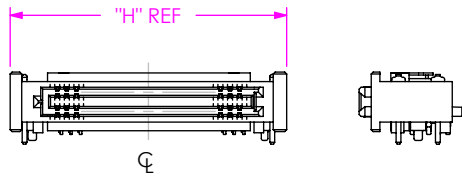
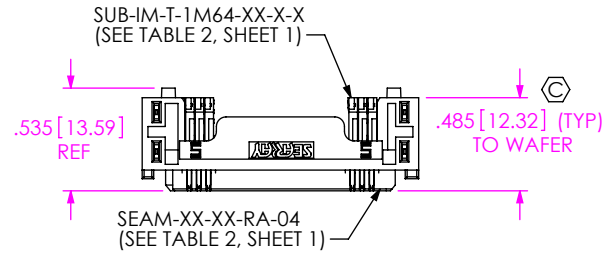

FIG 2
 (SEAM-20-01-X-04-X-RA SHOWN)
 (SAME AS FIG 1 EXCEPT AS NOTED)
 (SOME DETAIL REMOVED FOR CLARITY)

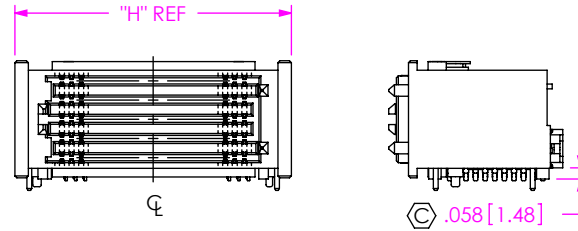
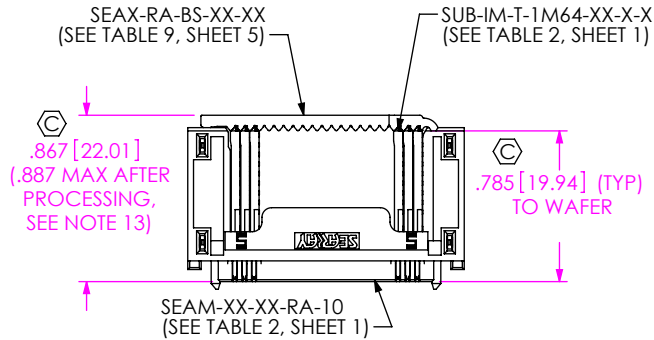

FIG 7
 (SEAM-20-01-X-10-X-RA SHOWN)
 (SAME AS FIG 4 EXCEPT AS NOTED)
 (SOME DETAIL REMOVED FOR CLARITY)

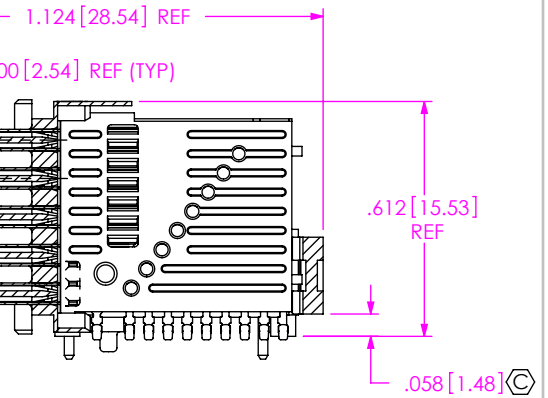
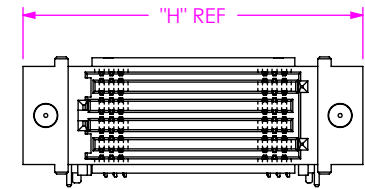
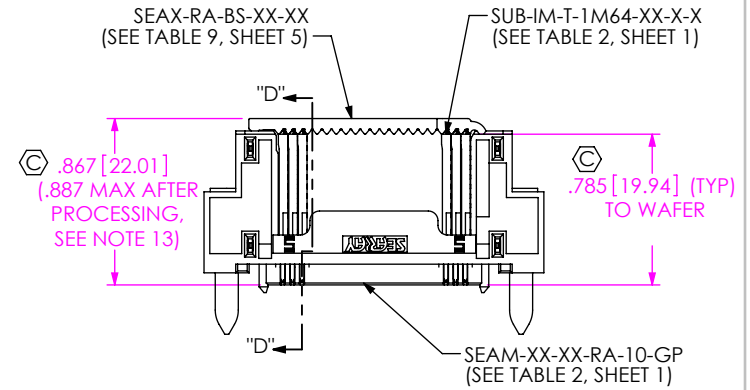

FIG 4
 (SEAM-20-01-X-10-X-RA-GP)
 (SAME AS FIG 1 EXCEPT AS NOTED)
 (SOME DETAIL REMOVED FOR CLARITY)

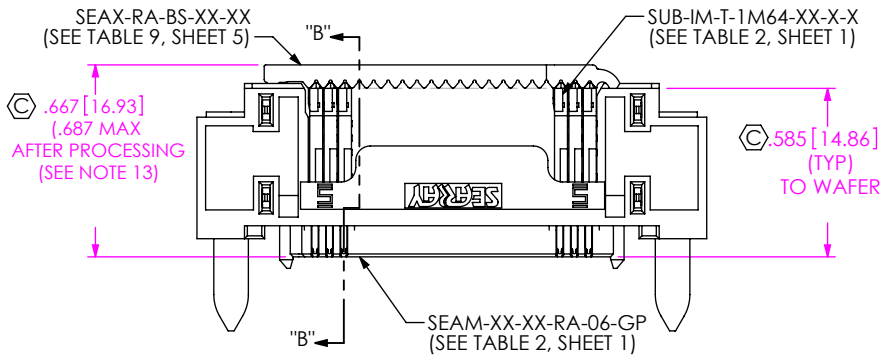
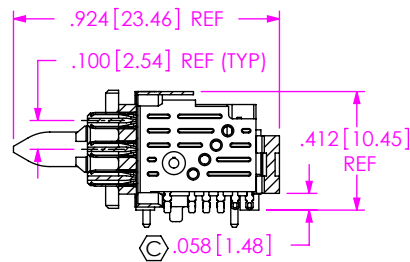

FIG 3
 (SEAM-20-01-X-06-X-RA-GP)
 (SAME AS FIG 1 EXCEPT AS NOTED)
 (SOME DETAIL REMOVED FOR CLARITY)



SECTION "B"- "B"
 SCALE 1.5 : 1

PROPRIETARY NOTE
 THIS DOCUMENT CONTAINS CONFIDENTIAL AND PROPRIETARY INFORMATION AND ALL DESIGN, MANUFACTURING, REPRODUCTION, USE, PATENT RIGHTS AND SALES RIGHTS ARE EXPRESSLY RESERVED BY SAMTEC, INC. THIS DOCUMENT SHALL NOT BE DISCLOSED, IN WHOLE OR PART, TO ANY UNAUTHORIZED PERSON OR ENTITY NOR REPRODUCED, TRANSFERRED OR INCORPORATED IN ANY OTHER PROJECT IN ANY MANNER WITHOUT THE EXPRESS WRITTEN CONSENT OF SAMTEC, INC.

DO NOT SCALE DRAWING

SHEET SCALE: 1:1



520 PARK EAST BLVD, NEW ALBANY, IN 47150
 PHONE: 812-944-6733 FAX: 812-948-5047
 e-Mail info@SAMTEC.com code 55322

DESCRIPTION:
 SEAM-RA ASSEMBLY
 DWG. NO.
 SEAM-XX-XX-X-XX-X-RA-XX-X-XR
 BY: R MUSSER 06/27/2008 SHEET 3 OF 5

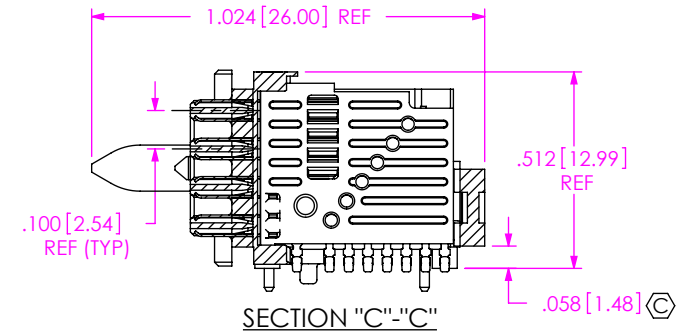
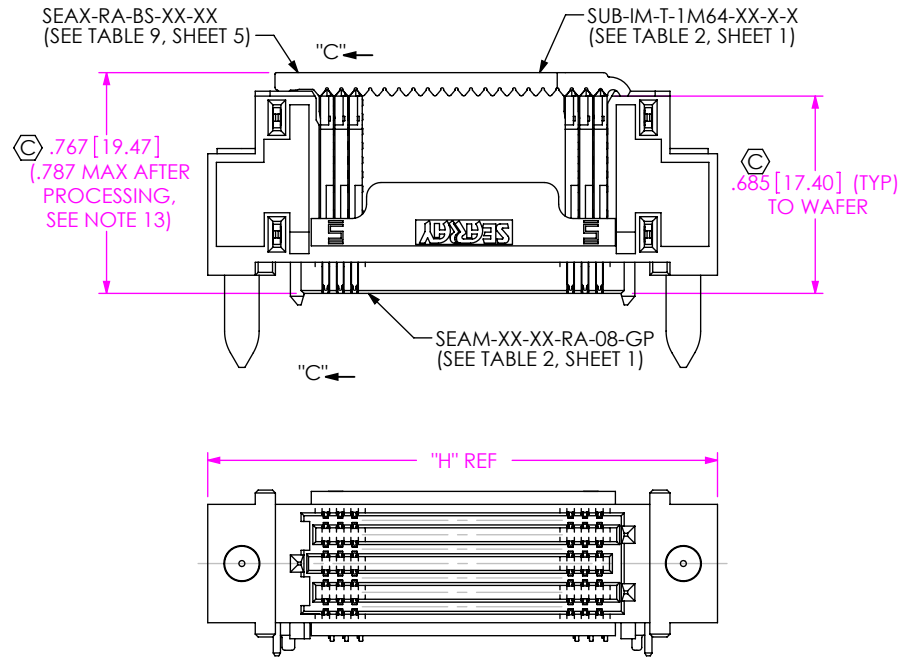

FIG 5
(SEAM-20-01-X-08-X-RA-GP)
(SAME AS FIG 1 EXCEPT AS NOTED)
(SOME DETAIL REMOVED FOR CLARITY)

ROWS	TABLE 5												
	"K"		"P" DIA.		"J" NO -GP OPTION				"J" WITH -GP OPTION				"Q"
					20 POS	30 POS	40 POS	50 POS	20 POS	30 POS	40 POS	50 POS	
-04	.317	[8.05]	.295	[7.49]	.573 [14.54]	.823 [20.89]	1.073 [27.24]	1.323 [33.59]	.738 [18.73]	.988 [25.08]	1.238 [31.43]	1.488 [37.78]	.128 [3.25]
-06	.417	[10.59]	.295	[7.49]	.573 [14.54]	.823 [20.89]	1.073 [27.24]	1.323 [33.59]	.738 [18.73]	.988 [25.08]	1.238 [31.43]	1.488 [37.78]	.128 [3.25]
-08	.524	[13.31]	.649	[16.48]	.396 [10.05]	.646 [16.40]	.896 [22.75]	1.146 [29.10]	.561 [14.24]	.811 [20.59]	1.061 [26.94]	1.311 [33.29]	.030 [0.76]
-10	.624	[15.85]	.649	[16.48]	.396 [10.05]	.646 [16.40]	.896 [22.75]	1.146 [29.10]	.561 [14.24]	.811 [20.59]	1.061 [26.94]	1.311 [33.29]	.030 [0.76]

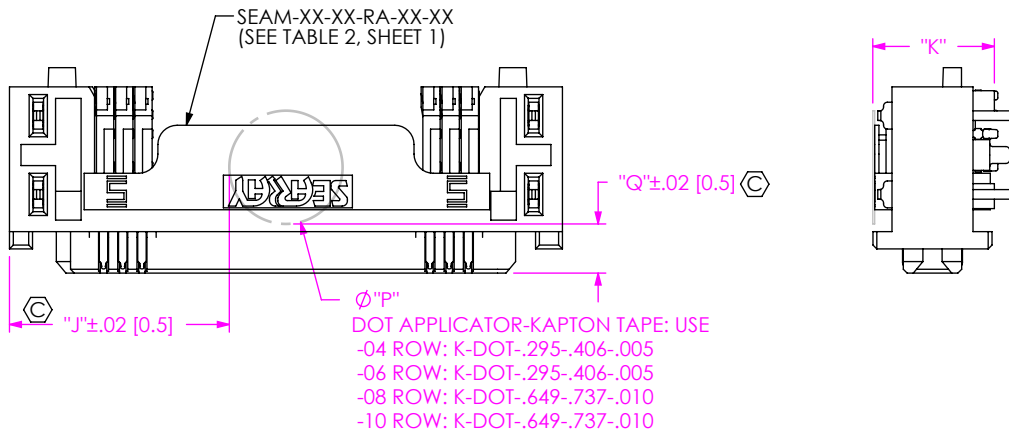

FIG 6
-K OPTION
(USE K-DOT-.XXX-.XXX-.XXX)
(SEAM-20-01-X-04-X-RA-K SHOWN)

<p>PROPRIETARY NOTE</p> <p>THIS DOCUMENT CONTAINS CONFIDENTIAL AND PROPRIETARY INFORMATION AND ALL DESIGN, MANUFACTURING, REPRODUCTION, USE, PATENT RIGHTS AND SALES RIGHTS ARE EXPRESSLY RESERVED BY SAMTEC, INC. THIS DOCUMENT SHALL NOT BE DISCLOSED, IN WHOLE OR PART, TO ANY UNAUTHORIZED PERSON OR ENTITY NOR REPRODUCED, TRANSFERRED OR INCORPORATED IN ANY OTHER PROJECT IN ANY MANNER WITHOUT THE EXPRESS WRITTEN CONSENT OF SAMTEC, INC.</p> <p>DO NOT SCALE DRAWING</p> <p>SHEET SCALE: 2:1</p>	<p>520 PARK EAST BLVD, NEW ALBANY, IN 47150 PHONE: 812-944-6733 FAX: 812-948-5047 e-Mail info@SAMTEC.com code 55322</p>
	<p>DESCRIPTION: SEAM-RA ASSEMBLY</p>
	<p>DWG. NO. SEAM-XX-XX-X-XX-X-RA-XX-X-R</p>
	<p>BY: R MUSSER 06/27/2008 SHEET 4 OF 5</p>

NOTE:
 FIG 8, DIMENSION "R" INDICATES CONNECTOR/FIXTURE HEIGHT ON PCB.
 TO GUARANTEE ENOUGH REFLOW OVEN WORKING SPACE, DIMENSION "R",
 PCB THICKNESS, AND THE HEIGHT OF THE COMPONENTS ON THE OPPOSITE
 SIDE OF THE BOARD NEED TO BE CONSIDERED.

TABLE 10		
SEARAY FIXTURE TOOLS		
PART NUMBER	POSITIONS	ROW
CAT-SEAM-20-08-RA	-20	-08
CAT-SEAM-30-08-RA	-30	-08
CAT-SEAM-40-08-RA	-40	-08
CAT-SEAM-50-08-RA	-50	-08
CAT-SEAM-20-10-RA	-20	-10
CAT-SEAM-30-10-RA	-30	-10
CAT-SEAM-40-10-RA	-40	-10
CAT-SEAM-50-10-RA	-50	-10

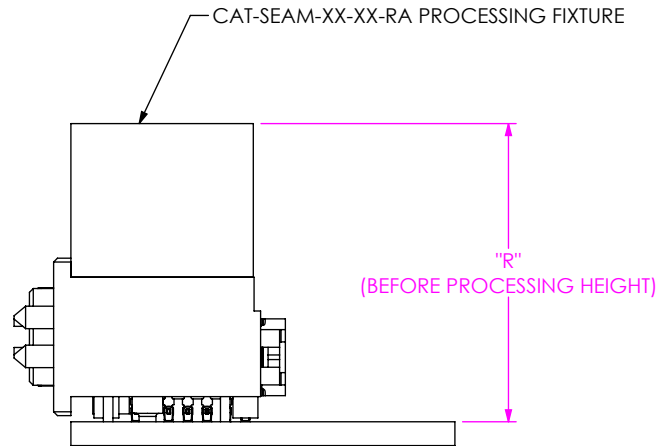

TABLE 6	
ROW	"R"
-08	.877 [22.28]
-10	.977 [24.82]

FIG 8
 SEAM-RA PROCESSING FIXTURE
 (USE CAT-SEAM-XX-XX-RA FIXTURE)

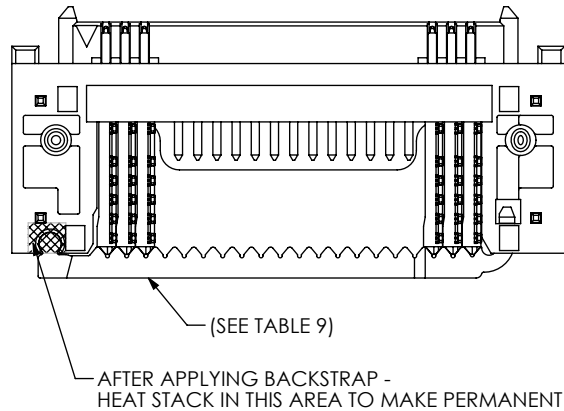

TABLE 9	
No. OF POSITIONS	"BACKSTRAP"
-20	SEAX-RA-BS-20-01
-30	SEAX-RA-BS-30-01
-40	SEAX-RA-BS-40-01
-50	SEAX-RA-BS-50-01

FIG 9
 HEAT STAKING BACKSTRAP

PROPRIETARY NOTE
 THIS DOCUMENT CONTAINS CONFIDENTIAL AND PROPRIETARY INFORMATION AND ALL DESIGN, MANUFACTURING, REPRODUCTION, USE, PATENT RIGHTS AND SALES RIGHTS ARE EXPRESSLY RESERVED BY SAMTEC, INC. THIS DOCUMENT SHALL NOT BE DISCLOSED, IN WHOLE OR PART, TO ANY UNAUTHORIZED PERSON OR ENTITY NOR REPRODUCED, TRANSFERRED OR INCORPORATED IN ANY OTHER PROJECT IN ANY MANNER WITHOUT THE EXPRESS WRITTEN CONSENT OF SAMTEC, INC.

DO NOT SCALE DRAWING

SHEET SCALE: 1:1



520 PARK EAST BLVD, NEW ALBANY, IN 47150
 PHONE: 812-944-6733 FAX: 812-948-5047
 e-Mail info@SAMTEC.com code 55322

DESCRIPTION:
 SEAM-RA ASSEMBLY

DWG. NO.
 SEAM-XX-XX-X-XX-X-RA-XX-X-XR

BY: R MUSSER 06/27/2008 SHEET 5 OF 5