

REVISION Y

DO NOT SCALE FROM THIS PRINT

NOTES:

1. $\text{\textcircled{C}}$ REPRESENTS A CRITICAL DIMENSION.
2. MAXIMUM HEIGHT VARIATION BETWEEN ANY TWO PINS: .005[0.13]
3. MAXIMUM PIN ROTATION IN BODY: 2°
4. TAILS TO BE SHEARED TO ACHIEVE DIMENSIONAL CALLOUT ± 0.10 [0.25]
5. MINIMUM PUSHOUT FORCE: 3 LBS.
6. MAXIMUM ALLOWABLE BURR: .0015[0.038]
7. THROUGH HOLES (-S & -RA) ARE TO BE BULK PACKAGED.
8. SURFACE MOUNT (-VS) IS TO BE PACKAGED AS FOLLOWS:
POSITIONS -04 THRU -20 ARE TO BE TUBE PACKAGED;
POSITION -02 TO BE LAYER PACKAGED,
-03 POSITION TO BE TUBE OR LAYER PACKAGED.
9. MAXIMUM CUT FLASH: .020[0.51]
10. COPLANARITY (-VS); POSITIONS -02 THRU -15: .008[0.20],
POSITIONS -16 THRU -20: .010[0.25]

HPM-XX-XX-XX-X-XX-X

No OF POSITIONS
-01 THRU -20

LEAD STYLE
SEE TABLE 1

PLATING SPECIFICATIONS
-T: MATTE TIN CONTACT AND TAIL
-TM: MATTE TIN CONTACT AND TAIL

OPTION
-P: PICK PLACE PAD (USE PPP-47) (-VS ONLY, 3 POS MIN, NOT AVAILABLE IN -05 LEAD STYLE)

OPTION
-RA: RIGHT ANGLE POST (-02 & -04 LEAD STYLE ONLY)
-VS: VERTICAL SURFACE MOUNT (-01 & -02 LEAD STYLE ONLY) (2 POSITION MINIMUM)

ROW SPECIFICATION
-S: SINGLE
SEE TABLE 2

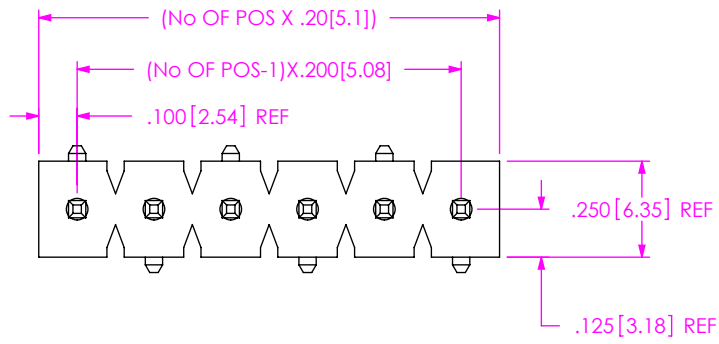

FORM	BODY	MATERIAL
T/H	FSW-20-200	BLACK, PBT, UL 94 VO
RA	FSW-20-200	
VS	HFSW-20-200	NATURAL, LCP, UL 94 VO

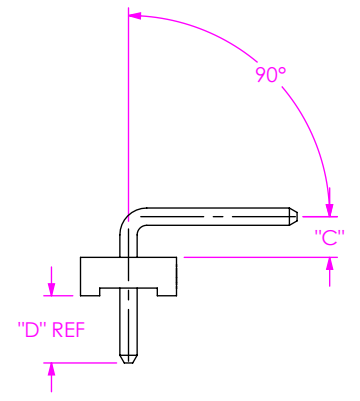
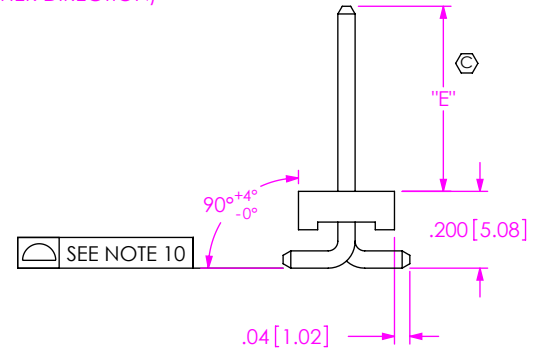
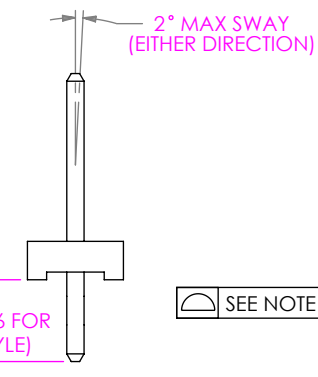
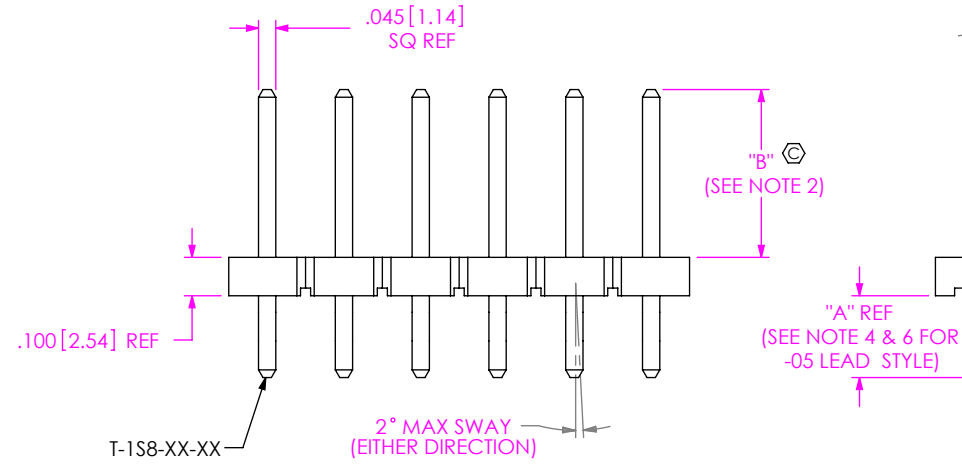

-S: SINGLE

-VS: SURFACE MOUNT
-01 & -02 ONLY

-RA: RIGHT ANGLE
-02 & -04 ONLY

STYLE	TERMINAL	"A"	"B"	"C"	"D"	"E"
-01	T-1S8-11-TX	.180 [4.57]	.470 [11.94]	N/A	N/A	N/A
-01-VS	T-1S8-12-TX	N/A	N/A	N/A	N/A	.422 [10.72]
-02	T-1S8-12-TX	.180 [4.57]	.520 [13.21]	.100 [2.54]	.175 [4.45]	.482 [12.24]
-04	T-1S8-14-TX	.161 [4.09]	.829 [21.06]	.195 [4.95]	.156 [3.96]	N/A
-05	T-1S8-11-TX	.180 [4.57]	.150 [3.81]	N/A	N/A	N/A
-06	T-1S8-15-TX	.180 [4.57]	1.070 [27.18]	N/A	N/A	N/A

UNLESS OTHERWISE SPECIFIED, DIMENSIONS ARE IN INCHES.
TOLERANCES ARE:
DECIMALS ANGLES
.XX: ± 0.1 [0.3] 2°
.XXX: ± 0.05 [0.13]
.XXXX: ± 0.020 [0.051]

PROPRIETARY NOTE
THIS DOCUMENT CONTAINS CONFIDENTIAL AND PROPRIETARY INFORMATION AND ALL DESIGN, MANUFACTURING, REPRODUCTION, USE, PATENT RIGHTS AND SALES RIGHTS ARE EXPRESSLY RESERVED BY SAMTEC, INC. THIS DOCUMENT SHALL NOT BE DISCLOSED, IN WHOLE OR PART, TO ANY UNAUTHORIZED PERSON OR ENTITY NOR REPRODUCED, TRANSFERRED OR INCORPORATED IN ANY OTHER PROJECT IN ANY MANNER WITHOUT THE EXPRESS WRITTEN CONSENT OF SAMTEC, INC.



520 PARK EAST BLVD, NEW ALBANY, IN 47150
PHONE: 812-944-6733 FAX: 812-948-5047
e-Mail: info@SAMTEC.com code 55322

MATERIAL: DO NOT SCALE DRAWING SHEET SCALE: 2:1
BODY: SEE TABLE 2
TERMINAL: CDA7025 GRADE TL02
MAX BOW ALLOWED: .003 IN/IN

DESCRIPTION: .200 HIGH POWER BLOCK, ASM
DWG. NO. HPM-XX-XX-XX-X-XX-X

NOTE:
 "R"=No OF POS X .200[5.08] REF
 "S"= $\{("R" -.450[11.43])/2\} \pm .020[.51]$
 "G"= POST HEIGHT +.050[1.27] REF

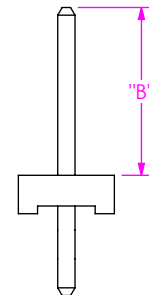
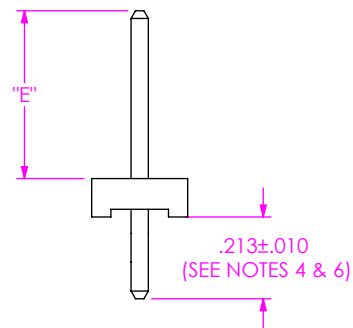
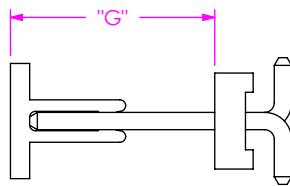
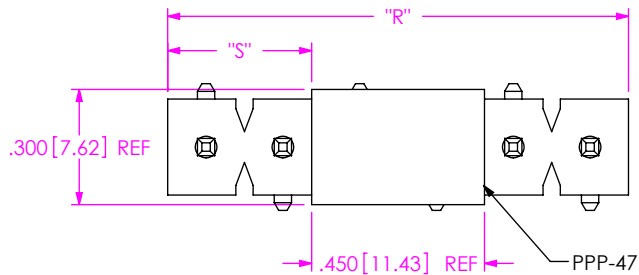

-P: PICK & PLACE PAD OPTION
 (-VS ONLY, 3 POS MIN)
 (NOT AVAILABLE IN -05 LEAD STYLE)

IN-PROCESS
 -VS

IN-PROCESS
 -RA

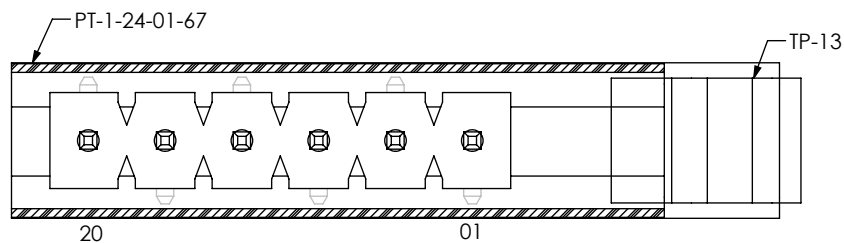

-VS

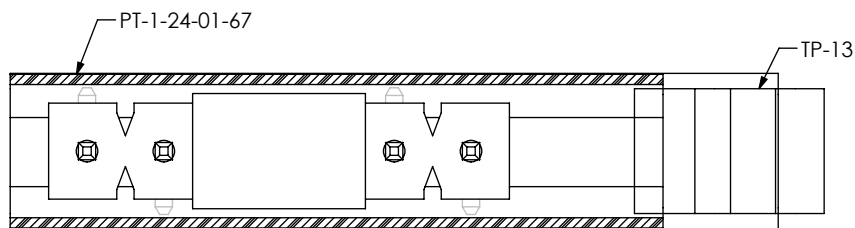
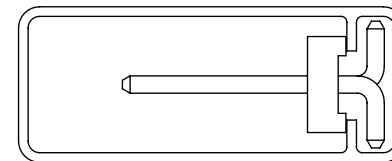

-VS-P

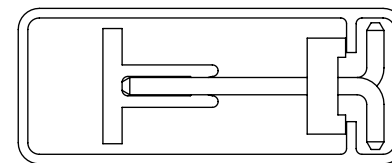

PACKAGING VIEW
 (SEE NOTE 7 & 8)

PROPRIETARY NOTE
 THIS DOCUMENT CONTAINS CONFIDENTIAL AND PROPRIETARY INFORMATION AND ALL DESIGN, MANUFACTURING, REPRODUCTION, USE, PATENT RIGHTS AND SALES RIGHTS ARE EXPRESSLY RESERVED BY SAMTEC, INC. THIS DOCUMENT SHALL NOT BE DISCLOSED, IN WHOLE OR PART, TO ANY UNAUTHORIZED PERSON OR ENTITY NOR REPRODUCED, TRANSFERRED OR INCORPORATED IN ANY OTHER PROJECT IN ANY MANNER WITHOUT THE EXPRESS WRITTEN CONSENT OF SAMTEC, INC.

DO NOT SCALE DRAWING

SHEET SCALE: 1:1

samtec

520 PARK EAST BLVD, NEW ALBANY, IN 47150
 PHONE: 812-944-6733 FAX: 812-948-5047
 e-Mail info@SAMTEC.com code 55322

DESCRIPTION: .200 HIGH POWER BLOCK, ASM

DWG. NO. HPM-XX-XX-XX-X-XX-X

BY: BURREN 08/21/98 SHEET 2 OF 2