



Specification For Approval

Customer : ALL Customer
Description : DC FAN
Dimension : 80*80*20mm
Model No. : PAAD18020BT P000
Revision : A
Specification No. : 705298
Customer Approval No. :
Issue Date : 25-May-2023

<i>Sales APPD.</i>	<i>Customer APPD.</i>	PLEASE SIGN AND RETURN THIS PAGE TO US FOR FILING AFTER AUTHENTICATION.
DAWN.	CHKD.	
<i>Lankai Xiang</i>		

BOYD

No. 116, Hua Ning Road, Dalang Town, Longhua New District, Shenzhen City,
Guangdong, China

TEL: +86-755-2777-8122 FAX: +86-755-2777-2833 Website: www.boydcorp.com

SPECIFICATION

1.MECHANICAL CHARACTERISTICS

MOTOR DESIGN	DC brushless 4 poles motor design
BEARING SYSTEM	Ball Bearing System
MATERIAL OF HOUSING	Thermoplastic PBT of UL 94V-0
MATERIAL OF FAN BLADE	Thermoplastic PBT of UL 94V-0
DIRECTION OF ROTATION	Counter-clockwise viewed from front of fan blade
WEIGHT(g)	75

2. ELECTRICAL CHARACTERISTICS

RATED VOLTAGE	12 VDC
INPUT CURRENT	0.33 A MAX: 0.6 A
INPUT POWER	3.96 W MAX: 7.2 W
OPERATING VOLTAGE RANGE	6~13.8 VDC
STARTING VOLTAGE	6 VDC (At 25°C, POWER ON/OFF)
OPERATING TEMPERATURE/ HUMIDITY RANGE	-10°C ~ +70°C / 5% ~ 90 %RH
STORAGE TEMPERATURE/ HUMIDITY RANGE	-40°C ~ +70°C / 5% ~ 95 %RH

PERFORMANCE CHARACTERISTICS

RATED SPEED(RPM)	4400RPM± 10%	(At 25 °C , After 10 minutes)
DUTY 50% SPEED(RPM)	-	
AIR FLOW	58.64 CFM	Min: 52.77 CFM
STATIC PRESSURE	7.08 mmH₂O	Min: 5.73 mmH₂O
SOUND PRESSURE NOISE(1m)	45 dB(A)	MAX: 48 dBA
INSULATION RESISTANCE PLASTIC FRAME	Min. 10MΩ at 500VDC between frame and (+) terminal.	
DIELECTRIC STRENGTH	5mA max. at 500VAC 60Hz 1 minute between frame and (+) terminal.	
LIFE EXPECTANCY	70,000Hours, at 40°C, 15%~65%RH	
PROTECTION	Automatic Restart	
	No Polarity Protection	
RoHS-Free Pb	RoHS compliance	
IP Protection Grade	No IP Protection	

SAFETY APPROVAL

SAFETY	UL & CUL	TUV
NO.	E181279	62368

PERFORMANCE CURVES

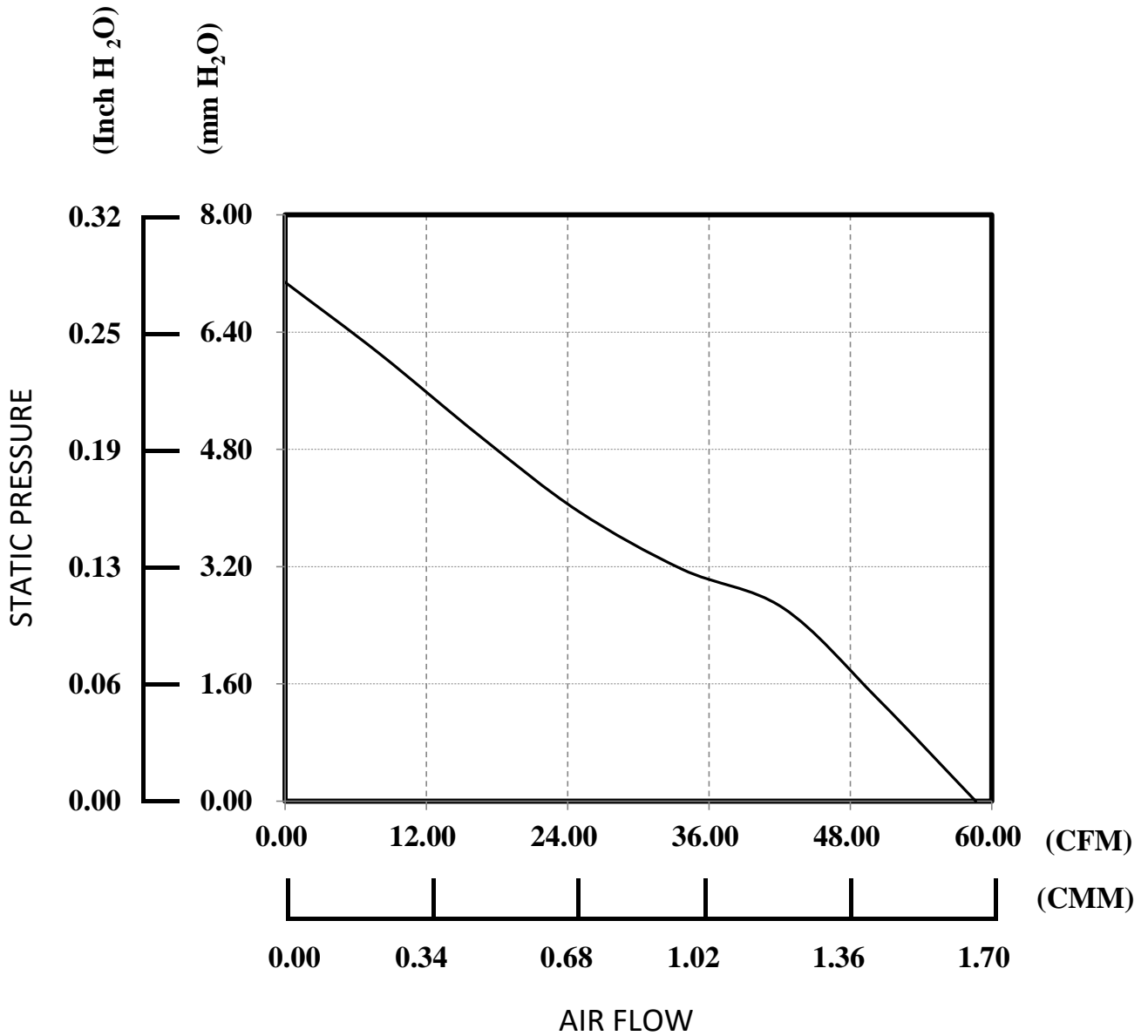

TEST CONDITION:

INPUT VOLTAGE ----- OPERATION VOLTAGE
 TEMPERATURE ----- ROOM TEMPERATURE
 HUMIDITY ----- 65%RH

DIMENSION

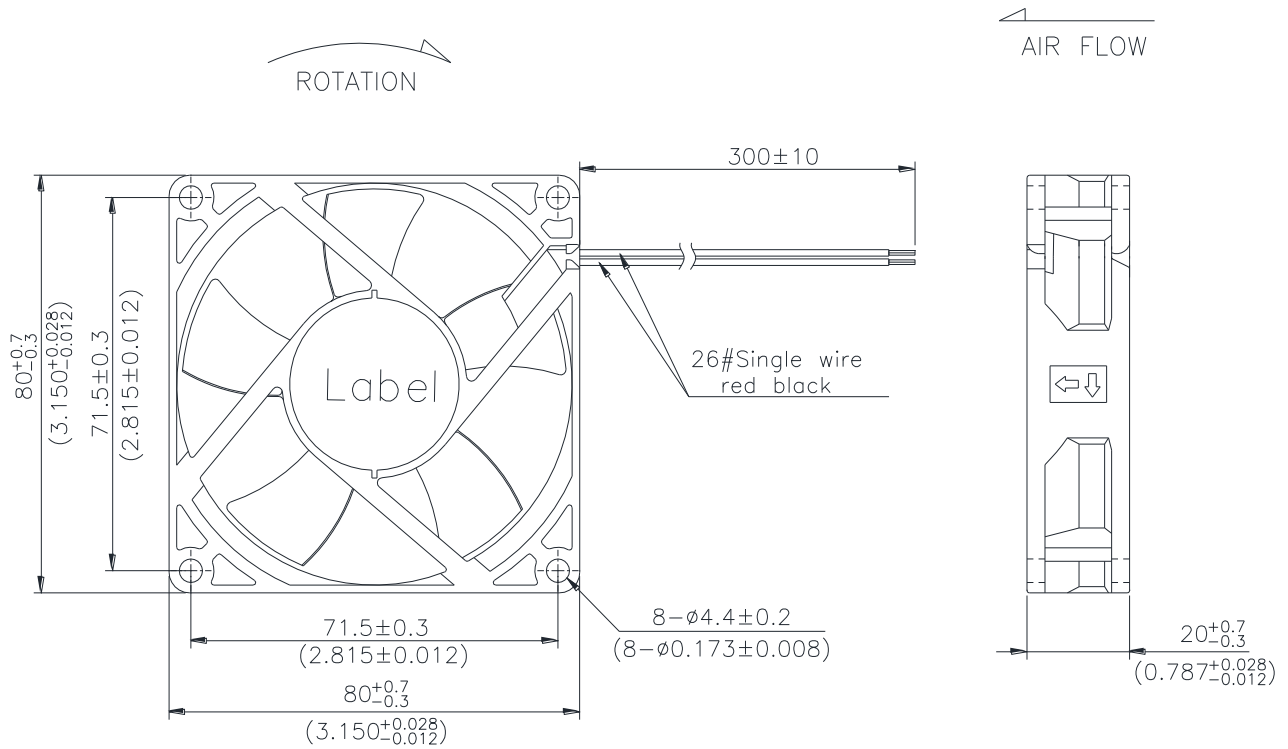

LABEL

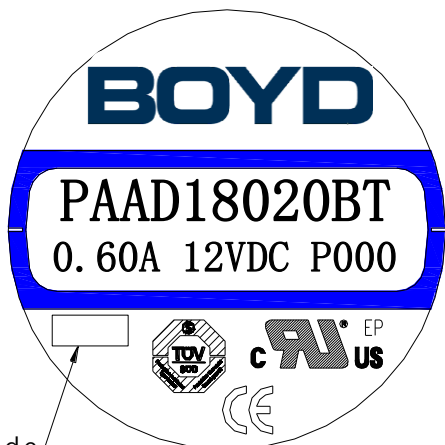

Date Code

1	35	2
last number of the year, e.g.: 1 stands for 2021, 2 stands for 2022 ... 9 stands for 2029 0 stands for 2020	week, e.g.: 35 stands for 35 week	the day of one week, e.g.: 1 stands for Monday, 2 stands for Tuesday, 6 stands for Saturday, 7 stands for Sunday.

Descriptions

- 1 BOYD will not guarantee the performance of the products if the application condition falls outside the parameters set forth in the specification.
- 2 A written request should be submitted to BOYD prior to approval if abnormality and deviation from this specification is required.
- 3 Please exercise caution when handling fans. Damage may be caused when pressure is applied to the impeller, or if the fans are handled by the lead wires, or if the fans are hard -dropped onto the production floor.

DON'T TOUCH !

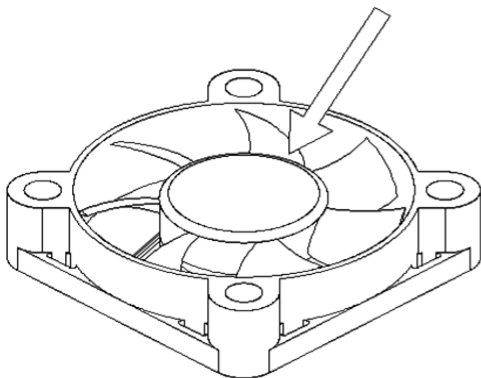

DON'T PUSH !

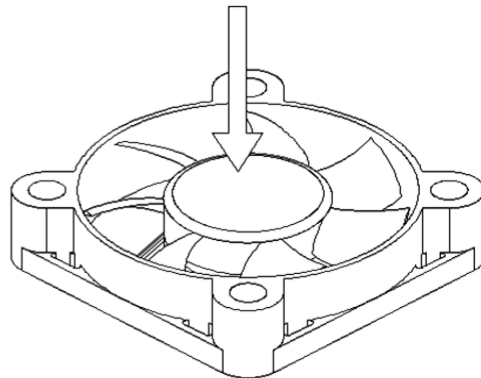

- 4 The correct polarity, Positive(+) and Negative(-), has to be clearly identified before connecting the fan to the power. Beware of the right connection as reversed polarity may cause damage since no effective protection can be introduced against such errors.
- 5 Except as pertains to some special designs, any failure and problems regarding safety of the product caused by the introduction of powder, droplets of water or encroachment of insert in the hub are not guaranteed.
- 6 BOYD fans are not suitable where any corrosive fluids are introduced to their environment.
- 7 Not all fans are provided with the Lock Rotor Protection feature. If you impair the rotation of the impeller for the fans that do not have this function, the performance of those fans will lead to failure.
- 8 It is important to consider safety when testing the fans. A suitable fan guard should be fitted to the fan guard against any potential for personal injury.
- 9 Please be cautious when mounting the fan. Incorrect mounting of fans may cause excess resonance, vibration and subsequent noise.
- 10 Please ensure all fans are stored according to the storage temperature limits specified. Do not store fans in a high humidity environment. We highly recommend performance testing is conducted before shipping, if the fans have been stored over 6 months.

Statement on RoHS Compliance

We guarantee that all the products including the parts 、 packaging materials conform to the Directives of RoHS (2015/863/EU)

No	Name of hazardous substance	Threshold value(ppm, mg/kg)
1	Cadmium and cadmium compounds(Cd)	100
2	Lead and lead compounds(Pb)	1000
3	Mercury and mercury compounds(Hg)	1000
4	Hexavalent chromium compounds(Cr6+)	1000
5	Polybrominated Biphenyls (PBB)	1000
6	Polybromodiphenyl ether (PBDE)	1000
7	Diethyl phthalate(DEHP)	1000
8	Butyl benzyl phthalate(BBP)	1000
9	Dibutyl phthalate (DBP)	1000
10	Diisodecyl-o-phthalate (DIDP)	1000

Products groups that exemptions from the Restriction of Hazardous Substances,(RoHS) Directive will following RoHS exceptions

If have other requirements, A new contract will draw up in additional for discuss .