

| | | | | |
|--|---|---|------------------------|-------------------|
| <p>CONFIDENTIAL. THE INFORMATION CONTAINED IN THIS DOCUMENT IS THE PROPERTY OF COOPER INDUSTRIES, INC. IT IS NOT FOR PUBLIC DISCLOSURE. POSSESSION OF THE INFORMATION DOES NOT CONVEY ANY RIGHT TO LOAN, SELL OR DISCLOSE THE INFORMATION. UNAUTHORIZED REPRODUCTION OR USE OF THE INFORMATION IS PROHIBITED. THIS DOCUMENT IS TO BE RETURNED TO COOPER INDUSTRIES, INC. UPON COMPLETION OF THE PURPOSE FOR WHICH IT IS LOANED OR UPON REQUEST.</p> <p>COPYRIGHT Cooper Industries, Inc. This is an unpublished work. The disclosure of this work is limited to select personnel. Further dissemination or disclosure to the public is PROHIBITED. This unpublished work is protected by Federal Copyright law and all rights thereunder are reserved by Cooper Industries, Inc.</p> | SCALE | UNLESS OTHERWISE SPECIFIED TOLERANCES TO BE: | DATE | NO. |
| | 4x | METRIC ±.13mm INCHES ±.005" ANGULAR ±2° | 3-19-05 | 1A3321 |
| | <p>▲ (O) INDICATES CRITICAL DIMENSION OR FEATURE</p> | THIRD ANGLE PROJECTION | TITLE WASHER | |
| | <p>INCHES (OR U.S. UNITS) IS THE PRIMARY UNIT OF MEASURE</p> <p>METRIC(mm) [INCHES]</p> | | SUP. NO. 1A3321 G | DATED 11-18-03 |
| | | DWG. CEM | CK. | REV. H |
| | | PAGE 1 OF 2 | | J05050 |
| <p>COOPER Bussmann St. Louis, MO 63178</p> | | | | |
| C/F NO. 64108 | | DISTRIBUTION | | J |

PART FEATURES TO BE SYMMETRICAL ABOUT INDICATED CENTER LINE WITHIN .25 TIR RFS.
[.010]

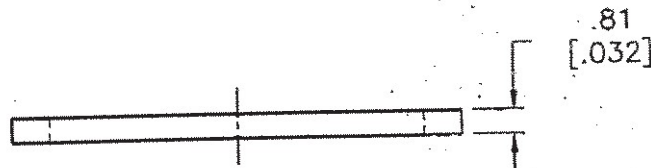
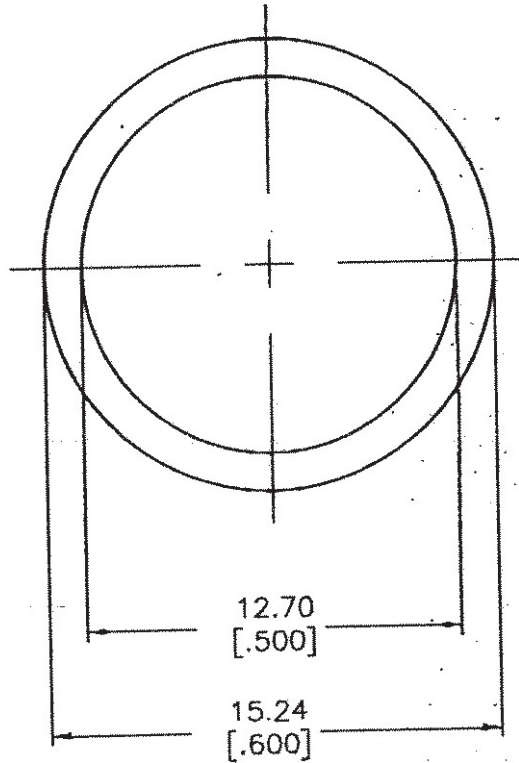

MATERIAL: NEOPRENE, DURO 70
BULK PACKAGING SPECIFICATION #1P1586

UNCONTROLLED COPY
COPIA NO CONTROLADA

FOR HTB FUSEHOLDERS

| PAGE 2 OF 2 | | DATE | TITLE | NO. |
|-------------|---|----------|---------|--------|
| | | 3-19-05 | WASHER | 1A3321 |
| REV. | CHANGE DESCRIPTION | DATE | ECN # | |
| B | CHANGED THK., MATERIAL & I.D. TOL | 11-12-82 | S20756 | |
| C | .600 WAS .595 | 9-28-83 | SN30831 | |
| D | FOR HTB WAS FOR HFH, HFL, HSH, HSL FUSEHOLDERS* MATERIAL WAS VELBUNA WG-5 | 11-8-90 | N00208 | |
| E | ADDED BULK PACKAGING SPECIFICATION #1P1586 | 5-29-98 | N98124 | |
| F | ADDED "J" TO DISTRIBUTION | 4-10-02 | SBO2153 | |
| G | REMOVED "N" FROM DISTRIBUTION | 11-18-03 | N03069 | |
| H | REDRAWN * .032 WAS V32" | 3-19-05 | J05050 | |
| | | | | |
| | | | | |
| | | | | |
| | | | | |
| | | | | |
| | | | | |
| | | | | |
| | | | | |
| | | | | |
| | | | | |
| | | | | |
| | | | | |

UNCONTROLLED COPY
COPIA NO CONTROLADA