

spec ref		dr Terran Huang		2010/07/09		projection 	MM \longleftrightarrow	size	A4	scale	21:10
tolerance std		eng Rahul Mohan-M		2021/07/21				ecn no	ELX-I-41712-1		
ISO 406 ISO 1101		chr -		-				rel level	Released		
surface 3.2		appr Kuriakose, San		2021/08/16		product family		METRAL			
ISO 1302		linear		0.X ± 0.3		product name		METRAL SIGNAL HEADER			
				0.XX ± 0.13		part no		74741			
				0.XXX ± 0.050		rev		R			
		angular		0° $\pm 2^\circ$		cat. no.		-			
		Amphenol FCi		amphenol-icc.com		Product - Customer Drw		sheet 1 of 4			

Creo F-114-ELX-MC-ACC, REV F, 2020-12-21

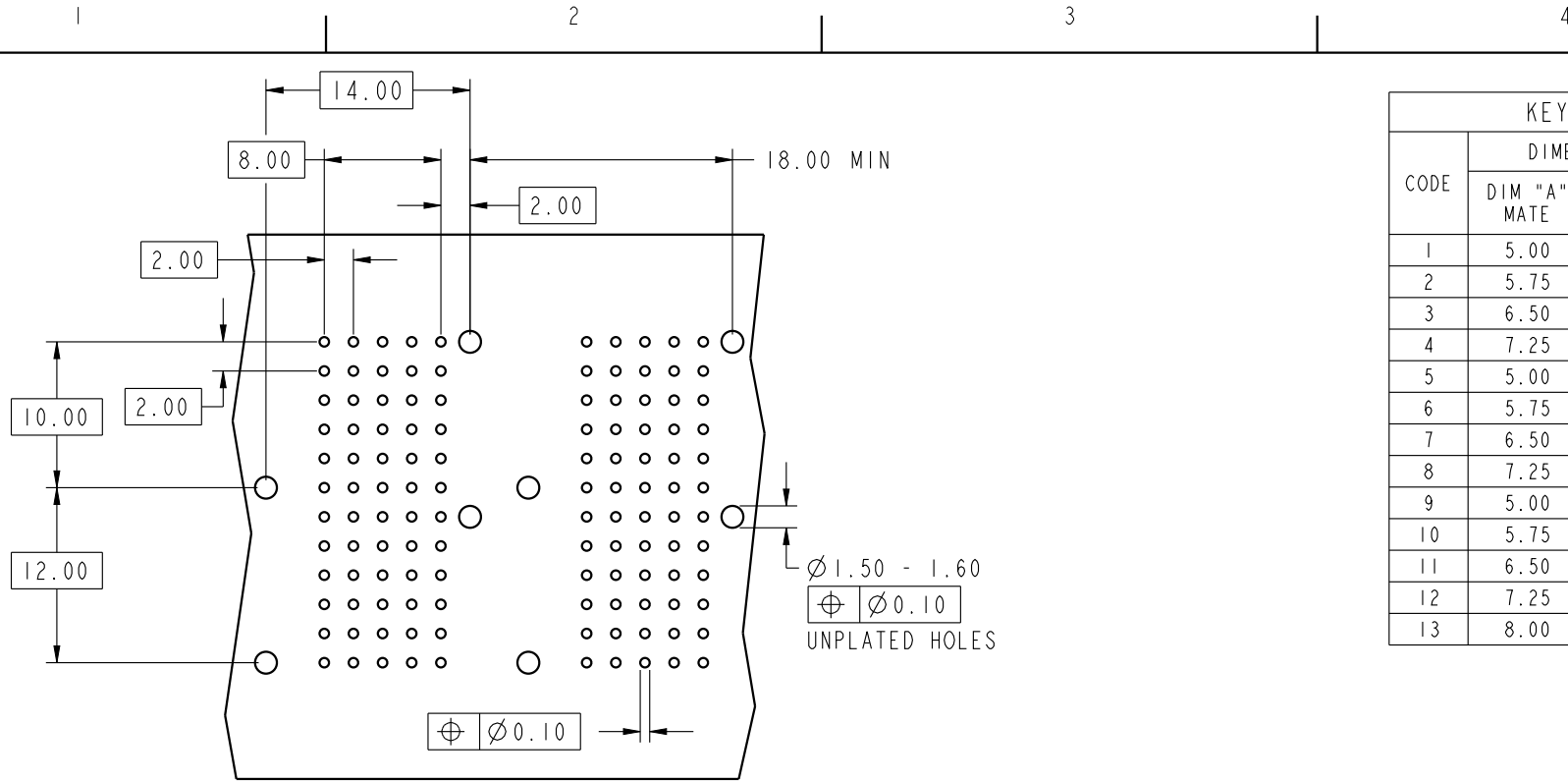

KEY		
CODE	DIMENSIONS	
	DIM "A" MATE	DIM "B" TAIL
1	5.00	4.25
2	5.75	4.25
3	6.50	4.25
4	7.25	4.25
5	5.00	3.30
6	5.75	3.30
7	6.50	3.30
8	7.25	3.30
9	5.00	2.65
10	5.75	2.65
11	6.50	2.65
12	7.25	2.65
13	8.00	4.25

REQUIRED PC BOARD LAYOUT
COMPONENT SIDE
SEE PRINT 58351 FOR
ADDITIONAL PCB INFORMATION

spec ref		dr	Terran Huang	2010/07/09	projection 	MM 	size	A4	scale	2:1:10	
tolerance std		eng	Rahul Mohan-M	2021/07/21			ecn no	ELX-I-41712-1			
ISO 406 ISO 1101		chr	-	-				rel level	Released		
surface 3.2		appr	Kuriakose, San	2021/08/16	product family		METRAL				
ISO 1302		TOLERANCES UNLESS OTHERWISE SPECIFIED		Amphenol FCI		title		METRAL SIGNAL HEADER		dwg no	rev
linear		0.X	±0.3	amphenol-icc.com		1 MOD, 5 ROW STB		74741			
angular		0°	±2°	cat. no.		-		Product - Customer Drw		sheet 2 of 4	

METRAL P/N	ROW	CONTACT CODE MOD. I					
		1	2	3	4	5	6
74741-X01LF	E	3	3	3	3	3	3
	D	3	3	3	3	3	3
	C	3	3	3	3	3	3
	B	3	3	3	3	3	3
	A	3	3	3	3	3	3

METRAL P/N	ROW	CONTACT CODE MOD. I					
		1	2	3	4	5	6
74741-X02LF	E	3	3	3	3	3	3
	D	4	4	4	4	4	4
	C	4	4	4	4	4	4
	B	4	4	4	4	4	4
	A	3	3	3	3	3	3

METRAL P/N	ROW	CONTACT CODE MOD. I					
		1	2	3	4	5	6
74741-X31LF	E	7	7	7	7	7	7
	D	7	7	7	7	7	7
	C	7	7	7	7	7	7
	B	7	7	7	7	7	7
	A	7	7	7	7	7	7

METRAL P/N	ROW	CONTACT CODE MOD. I					
		1	2	3	4	5	6
74741-X32LF	E	7	7	7	7	7	7
	D	8	8	8	8	8	8
	C	8	8	8	8	8	8
	B	8	8	8	8	8	8
	A	7	7	7	7	7	7

spec ref	dr	Terran Huang	2010/07/09	projection 	MM 	size	A4	scale	2:10
tolerance std	eng	Rahul Mohan-M	2021/07/21			ecn no	ELX-I-41712-1		
ISO 406 ISO 1101	chr	-	-			rel level	Released		
surface 3.2 ISO 1302	appr	Kuriakose, San	2021/08/16	product family	METRAL	rev			
linear	0.X	±0.3	Amphenol FCI	METRAL SIGNAL HEADER		dwg no	74741	rev	R
	0.XX	±0.13		1 MOD, 5 ROW STB					
	0.XXX	±0.050		cat. no.	-				
angular	0°	±2°	amphenol-icc.com	Product - Customer Drw		sheet 3 of 4			

METRAL P/N	ROW	CONTACT CODE MOD. I					
		1	2	3	4	5	6
74741-X81LF	E	5	5	5	5	5	5
	D	5	5	5	5	5	5
	C	5	5	5	5	5	5
	B	5	5	5	5	5	5
	A	7	7	7	7	7	7

METRAL P/N	ROW	CONTACT CODE MOD. I					
		1	2	3	4	5	6
74741-X85LF	E	3	3	3	3	3	3
	D	3	3	3	3	3	3
	C	-	-	-	-	-	-
	B	3	3	3	3	3	3
	A	3	3	3	3	3	3

METRAL P/N	ROW	CONTACT CODE MOD. I					
		1	2	3	4	5	6
74741-X82LF	E	6	6	6	6	6	6
	D	7	7	7	7	7	7
	C	6	6	6	6	6	6
	B	6	6	6	6	6	6
	A	7	7	7	7	7	7

METRAL P/N	ROW	CONTACT CODE MOD. I					
		1	2	3	4	5	6
74741-X83LF	E	6	6	6	6	6	6
	D	6	6	6	6	6	6
	C	6	6	6	6	6	6
	B	8	8	8	8	8	8
	A	6	6	6	6	6	6

METRAL P/N	ROW	CONTACT CODE MOD. I					
		1	2	3	4	5	6
74741-X84LF	E	8	8	8	8	8	8
	D	8	8	8	8	8	8
	C	8	8	8	8	8	8
	B	8	8	8	8	8	8
	A	8	8	8	8	8	8

NOTES:

- FOR DIM A AND B SEE SHEET 2 AND UP.
- MATERIAL : BODY : THERMOPLASTIC UL94-V0.
: CONTACT : COPPER ALLOY.
- FOR PLATING PERFORMANCE REFER DRAWING # 10159408.
- ALL PRODUCTS WITH PART NUMBERS SHOWN IN SUBSEQUENT TABLES WILL BE PACKAGED IN TUBES. IF TRAY PACKAGING IS REQUIRED, A SUFFIX "P" WILL BE ADDED TO THE END OF THE PART NUMBER. EXAMPLE:XXXXX-XXXPLF
- PRODUCT SPECIFICATION GS-12-180
- APPLICATION SPECIFICATION BUS-20-074
- THE PRODUCTS MEET THE EUROPEAN UNION DIRECTIVES AND OTHER COUNTRY REGULATIONS AS DESCRIBED IN GS-47-0004.
- ALL PRODUCTS WILL WITHSTAND EXPOSURE TO 260°C FOR 60 SECONDS IN A CONVECTION, INFRA-RED OR VAPOR PHASE REFLOW OVEN. THE Au CONTACT SURFACE OF THE CONTACTS SHALL BE EXPOSED TO A MAXIMUM 140°C FOR NO LONGER THAN 15 SECONDS IN A WAVE SOLDER APPLICATION.
- A Δ SYMBOL WILL BE NEXT TO ANY DIMENSION, VIEW, OR NOTE WHICH HAS BEEN MODIFIED WITH THE CURRENT DRAWING REVISION.

spec ref		dr	Terran Huang	2010/07/09	projection 	MM 	size	A4	scale	2:10
tolerance std		eng	Rahul Mohan-M	2021/07/21			ecn no	ELX-I-41712-1		
ISO 406 ISO 1101		chr	-	-			rel level	Released		
surface 3.2		appr	Kuriakose, San	2021/08/16	product family		METRAL			
ISO 1302	linear	0.X	±0.3		Amphenol FCi	METRAL SIGNAL HEADER	dwg no	74741	rev	R
		0.XX	±0.13							
		0.XXX	±0.050							
ISO 1302	angular	0°	±2°		amphenol-icc.com	cat. no.	-	Product - Customer Drw		sheet 4 of 4