

# MLX90427



Triaxis® Position Sensor IC with High Speed Serial Interface

Datasheet

## Features and Benefits

- Triaxis® Hall Technology
- On Chip Signal Processing for Robust Position Sensing
- **SIL** READY BY MELEXIS ISO26262 ASIL C Safety Element out of Context
- AEC-Q100 Qualified (Grade 0)
- High Speed Serial Interface (SPI compatible – Full Duplex)
- 16 bit RISC  $\mu$ Controller based digital signal processing
- Enhanced Self-Diagnostics Features
- 5V and 3V3 Application Compatible
- 14 bit Output Resolution
- 48 bit ID Number
- Single Die - SOIC-8, and Dual Die (Full Redundant) - TSSOP-16 package RoHS Compliant



SOIC-8

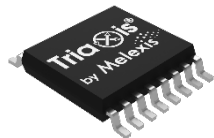

TSSOP-16

## Applications

- Absolute Contactless Position Sensor
- Steering Wheel Position Sensor
- 3D Joystick Position Sensor

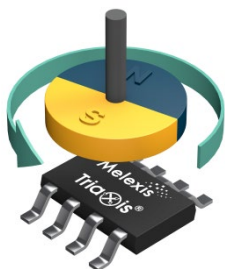

## Description

The MLX90427 is a monolithic magnetic position sensor IC. It consists of a Triaxis® Hall magnetic front end, an analog to digital signal conditioner, a DSP for advanced signal processing and an output stage driver.

The MLX90427 is sensitive to three ( $B_x$ ,  $B_y$  and  $B_z$ ) components of the flux density applied to the IC. This allows the MLX90427 to sense any magnet moving in its surrounding and decode its position through an appropriate signal processing.

Using its Serial Interface, the MLX90427 can transmit a digital output (SP – 64 bits per frame).

The MLX90427 is intended for Embedded Position Sensor applications (vs. Stand-Alone “Remote” Sensor) for which the output is directly provided to a microcontroller (Master) close to the MLX90427 (Slave). The SPI protocol confirms this intent.

The MLX90427 is using full duplex SPI protocol and requires therefore the separated SPI signal lines: MOSI, MISO, /CS and SCLK.

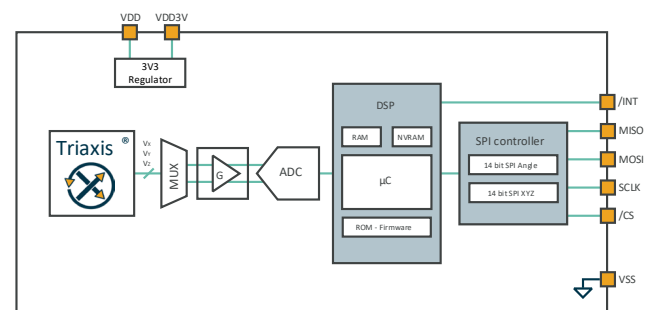

# 1. Ordering Information

Product Code	Temperature Code	Package Code	Option Code	Packing Form Code
MLX90427	G	DC	AAC-900	RE
MLX90427	G	GO	AAC-300	RE

Table 1 – Ordering codes

Temperature Code:	<b>G</b> : from -40 °C to 160 °C
Package Code:	<b>DC</b> : SOIC-8 package <b>GO</b> : TSSOP-16 package (dual die)
Option Code - Chip revision	<b>AAC-123</b> : <b>Chip Revision</b> <ul style="list-style-type: none"> <li><b>AAC</b>: MLX90427 production version</li> </ul>
Option Code - Application	<b>AAC-123</b> : <b>1-Application - Magnetic configuration</b> <ul style="list-style-type: none"> <li><b>3</b>: angular rotary mode <sup>(1)</sup></li> <li><b>9</b>: standard hybrid (360 Degree Strayfield Immune plus angular rotary) mode</li> </ul>
Option Code	<b>AAC-123</b> : <b>2-Option, 3-Option</b> <ul style="list-style-type: none"> <li><b>0</b>: standard</li> </ul>
Packing Form:	<b>RE</b> : Tape & Reel <ul style="list-style-type: none"> <li>3000 pcs/reel for SOIC-8 package, DC code</li> <li>4500 pcs/reel for TSSOP-16 package (dual die), GO code</li> </ul>
Ordering Example:	MLX90427GDC-AAC-900-RE For a standard hybrid magnetic mode in SOIC-8 package, delivered in Reel of 3000pcs.

Table 2 – Ordering codes information

<sup>1</sup> 360 Degree angular rotary sensing mode without strayfield immunity

# Contents

Features and Benefits.....	1
Applications.....	1
Description.....	1
1. Ordering Information .....	2
2. Functional Diagram .....	5
3. Glossary of Terms.....	6
4. Pin Definitions and Descriptions .....	7
4.1. Pin Definition for SOIC-8 Package .....	7
4.2. Pin Definition for TSSOP-16 Package .....	8
5. Absolute Maximum Ratings .....	9
6. Electrical Specification.....	10
6.1. Supply System .....	10
6.2. Supply System Monitoring .....	10
6.2.1. 5V supply application .....	10
6.2.2. 3V3 supply application .....	11
6.3. Input/Output Characteristics .....	12
7. Timing Specification.....	13
8. Magnetic Specification .....	14
9. Accuracy Specification.....	15
9.1. Angular Rotary Mode.....	15
9.2. 360 Degree Strayfield Immune Mode .....	17
9.3. Joystick Mode.....	17
9.4. Temperature Sensing.....	18
10. Serial Interface .....	19
10.1. Interface Timing Specification.....	19
10.2. Trigger Modes .....	20
10.3. Synchronization Function (SYNC).....	20
10.4. Master Interrupt Function .....	21
10.5. SPI Command Overview .....	21
10.6. SPI Command Timing Specification .....	23
11. Device Identification Items .....	25
12. End-User Programmable Items.....	26
12.1. Overview .....	26

12.2. Detailed description .....	31
12.2.1. System high-level functions .....	31
12.2.2. Physical layer.....	32
12.2.3. Magnetic modes .....	33
12.2.4. Digital signal processing .....	33
12.2.5. Digital signal processing for joystick mode .....	36
12.2.6. Diagnostics (safety mechanisms).....	40
12.2.7. Master interrupt function .....	45
12.2.8. Checksum.....	46
<b>13. Safety Mechanisms.....</b>	<b>47</b>
<b>14. Recommended Application Diagrams.....</b>	<b>50</b>
14.1. Recommended Application Diagram for SOIC-8 Package .....	50
14.1.1. MLX90427 in SOIC-8 Package and 5V Application.....	50
14.1.2. MLX90427 in SOIC-8 Package and 3V3 Application.....	50
14.2. Recommended Application Diagram for TSSOP-16 Package .....	51
14.2.1. MLX90427 in TSSOP-16 Package and 5V Application .....	51
14.2.2. MLX90427 in TSSOP-16 Package and 3V3 Application.....	52
<b>15. IC Handling and Assembly.....</b>	<b>53</b>
15.1. Storage and Handling of Plastic Encapsulated ICs .....	53
15.2. Assembly of Encapsulated ICs.....	53
15.3. Environment and Sustainability .....	53
<b>16. Package Information.....</b>	<b>54</b>
16.1. SOIC-8 Package .....	54
16.1.1. SOIC-8 – Package Dimensions.....	54
16.1.2. SOIC-8 – Pinout and Marking.....	55
16.1.3. SOIC-8 – Magnetic Sensitive Spot Positioning .....	55
16.1.4. SOIC-8 – Angle Detection .....	56
16.2. TSSOP-16 Package .....	57
16.2.1. TSSOP-16 – Package Dimensions.....	57
16.2.2. TSSOP-16 – Pinout and Marking.....	58
16.2.3. TSSOP-16 – Sensitive spot positioning .....	58
16.2.4. TSSOP-16 – Angle Detection .....	59
<b>17. Contact.....</b>	<b>60</b>
<b>18. Disclaimer.....</b>	<b>60</b>

## 2. Functional Diagram

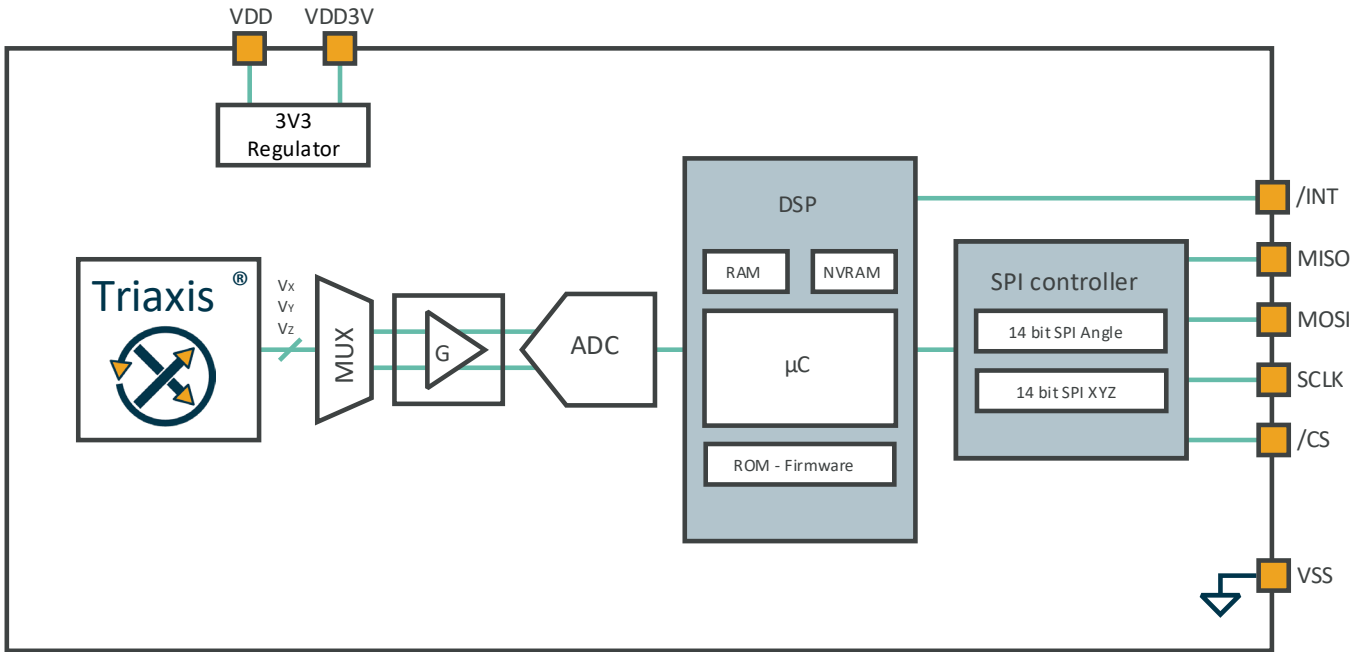

Figure 1 – MLX90427 Block Diagram

### 3. Glossary of Terms

Name	Description
ADC	Analog-to-Digital Converter
AoU	Assumption of Use
ASP	Analog Signal Processing
ATAN	ArcTANgent
AWD	Absolute WatchDog
Byte	8 bits
CoRDIC	Coordinate Rotation Digital Computer
CPU	Central Processing Unit
CRC	Cyclic Redundancy Check
DC	Duty Cycle of the output signal i.e. $T_{ON} / (T_{ON} + T_{OFF})$
DP	Discontinuity Point
DSP	Digital Signal Processing
DTI	Diagnostic Test Interval
ECC	Error Correcting Code
EMA	Exponential Moving Average
EMC	Electro-Magnetic Compatibility
EoL	End of Line
FHTI	Fault Handling Time Interval
FIR	Finite Impulse Response
FW	Firmware
Gauss (G)	Alternative unit for the magnetic flux density (10G = 1mT)
HW	Hardware

Name	Description
IMC®	Integrated Magnetic Concentrator
INL/DNL	Integral Non-Linearity / Differential Non-Linearity
IWD	Intelligent WatchDog
LNR	LiNeaRization
LSB/MSB	Least Significant Bit / Most Significant Bit
MSC	Message Sequence Chart
NC	Not Connected
NVRAM	Non Volatile RAM
POR	Power On Reset
PSF	Product Specific Functions
PWL	Piecewise Linear
RAM	Random Access Memory
RISC	Reduced Instruction Set Computer
ROM	Read-Only Memory
SEooc	Safety Element out of Context
TC	Temperature Coefficient (in ppm/°C)
Tesla (T)	SI derived unit for the magnetic flux density (Vs/m <sup>2</sup> )
Word	16 bits (= 2 Bytes)

*Table 3 – Glossary of terms*

## 4. Pin Definitions and Descriptions

### 4.1. Pin Definition for SOIC-8 Package

Pin #	Name	I/O Type	Description	Comments
1	/INT	Digital output	Active low interrupt output	Pulled-up to VDD_IO, open-drain output for interrupt or reset-by-interrupt functionality <sup>(2)</sup>
2	VDD3V	Supply	Regulated 3V supply	Decoupling Pin for 5V application Supply (Shorted to VDD) for 3V3 application
3	VSS	Ground	Ground	
4	VDD	Supply	Power supply	
5	/CS	Digital input	Active low SPI chip select or active low synchronization signal	Pulled-up to VDD_IO, configurable EMC filter
6	SCLK	Digital input	SPI clock	Configurable EMC filter
7	MOSI	Digital input	SPI input	Configurable EMC filter
8	MISO	Digital output	SPI output	

Table 4 – SOIC-8 pins definition and description

<sup>2</sup> The voltage on this pin shall not exceed  $VDD+0.3V$  to avoid forward-biasing of the parasitic diode versus VDD. See also chapter 5 for the corresponding absolute maximum rating.

## 4.2. Pin Definition for TSSOP-16 Package

Pin #	Name	I/O Type	Description	Comments
1	/INT1	Digital output	Active low interrupt output of die 1	Pulled-up to VDD_IO, open-drain output for interrupt or reset-by-interrupt functionality <sup>(2)</sup>
2	VDD3V1	Supply	Regulated 3V supply of die 1	Decoupling Pin for 5V application Supply (Shorted to VDD) for 3V3 application
3	VSS1	Ground	Ground of die 1	
4	VDD1	Supply	Power supply of die 1	
5	/CS2	Digital input	Active low SPI chip select or active low synchronization signal of die 2	Pulled-up to VDD_IO, configurable EMC filter
6	SCLK2	Digital input	SPI clock of die 2	Configurable EMC filter
7	MOSI2	Digital input	SPI input of die 2	Configurable EMC filter
8	MISO2	Digital output	SPI output of die 2	
9	/INT2	Digital output	Active low interrupt output of die 2	Pulled-up to VDD_IO, open-drain output for interrupt or reset-by-interrupt functionality <sup>(2)</sup>
10	VDD3V2	Supply	Regulated 3V supply of die 2	Decoupling Pin for 5V application Supply (Shorted to VDD) for 3V3 application
11	VSS2	Ground	Ground of die 2	
12	VDD2	Supply	Power supply of die 2	
13	/CS1	Digital input	Active low SPI chip select or active low synchronization signal of die 1	Pulled-up to VDD_IO, configurable EMC filter
14	SCLK1	Digital input	SPI clock of die 1	Configurable EMC filter
15	MOSI1	Digital input	SPI input of die 1	Configurable EMC filter
16	MISO1	Digital output	SPI output of die 1	

Table 5 – TSSOP-16 pins definition and description



## 5. Absolute Maximum Ratings

Parameter	Symbol	Min	Max	Unit	Condition
Supply Voltage	positive	$V_{DD}$	18	V	< 48h, for 5V application
	reverse	$V_{DD-rev}$	-0.3		
Supply Voltage	positive	$V_{DD}$	4	V	< 48h, for 3V3 application
	reverse	$V_{DD-rev}$	-0.3		
Output Voltage <sup>(3)</sup>	positive	$V_{OUT}$	min[6, $V_{DD} + 0.3$ ]	V	< 48h, for pins MISO, /INT
	reverse	$V_{OUT-rev}$	-0.3		
Input Voltage	positive	$V_{IN}$	18	V	< 48h, for pins MOSI, SCLK, /CS
	reverse	$V_{IN-rev}$	-0.3		
Operating Temperature	$T_{AMB}$	-40	+160	°C	
Junction Temperature	$T_J$		+175	°C	
Storage Temperature	$T_{ST}$	-55	+170	°C	
Magnetic Flux Density	$B_{max}$	-1	1	T	

Table 6 – Absolute maximum ratings

Exceeding the absolute maximum ratings may cause permanent damage. Exposure to absolute maximum-rated conditions for extended periods may affect device reliability.

<sup>3</sup> Optionally, 18V positive absolute maximum rating on the output pins could be supported by connecting a 1kΩ series resistor to the pin, see applications diagrams in chapter 14.

## 6. Electrical Specification

General electrical specifications are valid for temperature range [-40, 160] °C and the nominal supply voltage range for the corresponding application in Table 6, unless otherwise noted.

### 6.1. Supply System

Parameter	Symbol	Min	Typ	Max	Unit	Condition
Nominal Supply Voltage	VDD	4.5	5	5.5	V	5V application
		3.0	3.3	3.6	V	3V3 application
Supply Current <sup>(4)</sup>	IDD		9.5	12.5	mA	5V application
			9.5	11.5	mA	3V3 application
Standby Current <sup>(5)</sup>	IDD_STBY		110	140	µA	up to 125 °C, 5V application <sup>(6)</sup>
			110	200	µA	up to 160 °C, 5V application <sup>(6)</sup>

Table 7 – General electrical specifications of the supply system

### 6.2. Supply System Monitoring

#### 6.2.1. 5V supply application

Parameter	Symbol	Min	Typ	Max	Unit	Condition
Overvoltage detection hysteresis	VOVD_HYST_5V	100	150	200	mV	Normal state, trimmed.
Overvoltage detection hysteresis - Boot	VOVD_HYST_BOOT_5V	100	150	200	mV	Boot and standby states.
Overvoltage detection hysteresis - Tight setting <sup>(7)</sup>	VOVD_HYST_TIGHT_5V	100	125	150	mV	Normal state, trimmed.
Overvoltage detection level	VOVD_LH_5V	5.6		6.0	V	Rising voltage. Normal state, trimmed.
Overvoltage detection level	VOVD_HL_5V	5.5		5.9	V	Falling voltage. Normal state, trimmed.

<sup>4</sup> No SPI transaction ongoing. For the dual-die version, the supply current is multiplied by 2.

<sup>5</sup> Typical value is valid for 5V supply at 35°C, and the maximum value is valid for 5.5V supply at 160°C. The standby current increases with higher temperature and supply voltage.

<sup>6</sup> Standby mode in 3V3 application shall not be used.

<sup>7</sup> MLX90427 offers the option for a tighter overvoltage detection setting, see the description of the end-user programmable item "NV\_DIAG\_OV\_VDD\_SEL" in chapter 12.

Parameter	Symbol	Min	Typ	Max	Unit	Condition
Overvoltage detection level - Boot	VOVD_LH_BOOT_5V	5.5		6.1	V	Rising voltage. Boot and standby states.
Overvoltage detection level - Boot	VOVD_HL_BOOT_5V	5.4		5.9	V	Falling voltage. Boot and standby states.
Overvoltage detection level - Tight setting <sup>(7)</sup>	VOVD_HL_TIGHT_5V	5.3		5.7	V	Falling voltage. Normal state, trimmed.
Overvoltage detection level - Tight setting <sup>(7)</sup>	VOVD_LH_TIGHT_5V	5.5		5.8	V	Rising voltage. Normal state, trimmed.
Overvoltage standby detection hysteresis	VOVD_STBY_HYST	200	300	400	mV	
Overvoltage standby detection level	VOVD_STBY_HL	6.3	6.65	7.0	V	Falling voltage
Overvoltage standby detection level	VOVD_STBY_LH	6.6	6.95	7.3	V	Rising voltage.
Undervoltage detection hysteresis	VUVD_HYST_5V	100	250	400	mV	
Undervoltage detection level	VUVD_HL_5V	3.75		4.25	V	Falling voltage.
Undervoltage detection level	VUVD_LH_5V	4.0		4.5	V	Rising voltage.

*Table 8 – General electrical specifications of the monitoring on the supply system in 5V application*

## 6.2.2. 3V3 supply application

Parameter	Symbol	Min	Typ	Max	Unit	Condition
Overvoltage detection level	VOVD_HL_3V3	3.5		3.8	V	Falling voltage.
Overvoltage detection hysteresis	VOVD_HYST_3V3	50	100	150	mV	
Overvoltage detection level	VOVD_LH_3V3	3.6		3.9	V	Rising voltage.
Undervoltage detection level	VUVD_HL_3V3	2.7		2.95	V	Falling voltage.
Undervoltage detection hysteresis	VUVD_HYST_3V3	40	50	100	mV	
Undervoltage detection level	VUVD_LH_3V3	2.75		3.0	V	Rising voltage.

*Table 9 – General electrical specifications of the monitoring on the supply system in 3V3 application*

## 6.3. Input/Output Characteristics

Parameter	Symbol	Min	Typ	Max	Unit	Condition
Input capacitance	C <sub>IN</sub>			10	pF	pins MOSI, SCLK, /CS
Capacitive load	C <sub>L</sub>			20	pF	pin MISO, max SPI data rate
Output leakage current	I <sub>HZ_{LH}}</sub>	-5		5	μA	Pin MOSI in high-impedance state
Input current	I <sub>IN</sub>	-200		200	nA	Pins SCLK, MOSI
Input current CS_B	I <sub>IN_CS_B</sub>			100	nA	Pin /CS, pull-up only, minimum value is defined by R_PU_CS_B
Static output load current <sup>(8) (9)</sup>	I <sub>O_{LH}}</sub>	-0.4 -1.0		0.4 1.0	mA	pin MISO, weak drive configuration pin MISO, strong drive configuration
Output short current <sup>(8) (9)</sup>	I <sub>SC_{LH}}</sub>	-15 -40 -25 -65		20 50 20 45	mA	3V3 application, weak drive configuration 3V3 application, strong drive configuration 5V application, weak drive configuration 5V application, strong drive configuration
Input low voltage	V <sub>IL</sub>			30	%VDD	pins MOSI, SCLK, /CS
Input high voltage	V <sub>IH</sub>	70			%VDD	pins MOSI, SCLK, /CS
Output low voltage	V <sub>OL</sub>			10	%VDD	pins MISO, /INT, load =I <sub>O_L</sub>
Output high voltage <sup>(9)</sup>	V <sub>OH</sub>	90			%VDD	pins MISO, /INT, load =I <sub>O_H</sub>
Pull-up resistance /CS	R <sub>PU_CS_B</sub>	9	12	16	kΩ	pin /CS
Pull-up resistance /INT	R <sub>PU_INTB</sub>	9	13	20	kΩ	pin /INT
Dual-die pin-to-pin isolation	R <sub>ISO</sub>	4			MΩ	Resistance between any pin combination between dice in TSSOP-16 dual die package.

Table 10 – General electrical specifications of the input/output characteristics

<sup>8</sup> MISO output driver can be configured to have weak or strong driving strength via the end-user programmable item NV\_PHY\_MISO\_CONFIG[0], see Table 24.

<sup>9</sup> For I<sub>X\_H</sub> and V<sub>OH</sub>, pull-up is connected to VDD.

## 7. Timing Specification

The timing specifications are valid for temperature range [-40, 160] °C and the nominal supply voltage range for the corresponding application in Table 6, unless otherwise noted.

Parameter	Symbol	Min	Typ	Max	Unit	Condition
Start-up Time	t_startup			5	ms	From cold power-on to system in application mode
Safe start-up time	t_safe_start up			28	ms	From warm reset event to system back in application mode
Wake-up time	t_wake_up			5	ms	From wake-up event to system back in application mode
Wake-up signal hold time	t_hold_wup	1			μs	Wake-up condition on /CS pin (pulled down)
Normal trigger latency	t_trig_nor mal		120	140	μs	From end of SPI trigger transaction to APS start

*Table 11 – Timing specification*

## 8. Magnetic Specification

Magnetic field specifications are valid for temperature range [-40; 160] °C unless otherwise noted.

The normal operating conditions for the magnetic induction field magnitude for the Hall plates system with IMC® are defined as follows:

1. For rotary magnetic modes using in-plane magnetic fields only:  $B_{AMP} = \sqrt{B_x^2 + B_y^2}$
2. For rotary/linear magnetic modes in the XZ plane:  $B_{AMP} = \sqrt{B_x^2 + \left(\frac{1}{G_{IMC}} B_z\right)^2}$
3. For rotary/linear magnetic modes in the YZ plane:  $B_{AMP} = \sqrt{B_y^2 + \left(\frac{1}{G_{IMC}} B_z\right)^2}$
4. For the joystick mode:  $B_{AMP} = \sqrt{B_x^2 + B_y^2 + \left(\frac{1}{G_{IMC}} B_z\right)^2}$

The parameter  $G_{IMC}$  represents the IMC® gain, which is a correction factor applied to the z field component when the IMC® is present, to account for the better magnetic sensitivity of the in-plane (x-y) field components concentrated by the IMC®.

For the Hall plates measurements in the 360 Degree Strayfield Immune mode, the magnitude of in-plane field components is irrelevant.

Parameter	Symbol	Min	Typ	Max	Unit	Condition
Magnetic Flux Density on X- or Y- axis	$B_{AMP}$	20	50	70 <sup>(10)</sup>	mT	Normal performance range
		10		20	mT	Limited performance range
IMC® Gain	$G_{IMC}$		1.16			the ratio between the in-plane field components concentrated by the IMC® and the out-of-plane field components
Magnetic Flux Density on Z-axis	$B_z$			170	mT	For 360 Degree Strayfield Immune mode. In case of the angular rotary modes, limitations for the overall magnetic flux density shall apply
Magnetic out-of-plane field gradient	$dB_z$	10		200	mT/mm	For 360 Degree Strayfield Immune mode, approximated as constant within 1mm radius from magnet sensitive spot
Hall Plates Spacing	$\Delta X, \Delta Y$		1.70		mm	For 360 Degree Strayfield Immune mode, distance between the two hall plates of a measurement axis

Table 12 – Magnetic specifications

<sup>10</sup> Above 70 mT, the IMC® starts saturating yielding to an increase of the linearity error.

## 9. Accuracy Specification

Valid before EoL calibration and for all applications under the conditions described in chapter 8. For the TSSOP-16 package (code “GO”), the off-axis (see sections 16.2.3 and 16.2.4) error is not included.

### 9.1. Angular Rotary Mode

Table 13 below summarizes the MLX90427 legacy rotary mode performance when operating in the normal performance range defined in Table 12.

Parameter	Symbol	Min	Typ	Max	Unit	Condition
Linearity error drift	ANG_DERR_XY	-0.56		0.56	Deg.	Angle in XY plane, relative to 35 °C, 5V application
Linearity error drift	ANG_DERR_XY_3V3	-0.8		0.8	Deg.	Angle in XY plane, relative to 35 °C, 3V3 application
Linearity error drift with supply	ANG_DERR_XY_SUP	-0.6		0.6	Deg.	Angle in XY plane, relative to 3.3V supply voltage, for supply range in [3.0, 3.6] V in 3V3 application
Linearity error drift	ANG_DERR_{X,Y}Z	-0.8		0.8	Deg.	Angle in XZ or YZ plane, relative to 35 °C, valid for both 5V and 3V3 applications
Intrinsic linearity error	ANG_ERR_XY	-1.0		1.0	Deg.	Angle in XY plane
Intrinsic linearity error	ANG_ERR_{X,Y}Z	-1.5		1.5	Deg.	Angle in XZ or YZ plane
Hysteresis	ANG_HYST		0.05	0.1	Deg.	
Magnetic angular noise <sup>(11)</sup>	ANG_NOISE			0.2	Deg.	20mT up to 125 °C, no post-processing filter
				0.3	Deg.	20mT up to 160 °C, no post-processing filter

*Table 13 – Angular rotary mode performance in normal performance range*

<sup>11</sup>  $6\sigma$  (peak-to-peak approximation), 1000 consecutive measurements.

Table 14 below summarizes the MLX90427 angular rotary mode performance when operating in the limited performance range defined in Table 12.

Parameter	Symbol	Min	Typ	Max	Unit	Condition
Linearity error drift	ANG_DERR_XY	-0.7		0.7	Deg.	Angle in XY plane, relative to 35 °C 5V application
Linearity error drift	ANG_DERR_XY_3V3	-0.8		0.8	Deg.	Angle in XY plane, relative to 35 °C, 3V3 application
Linearity error drift with supply	ANG_DERR_XY_SUP	-0.8		0.8	Deg.	Angle in XY plane, relative to 3.3V supply voltage, for supply range in [3.0, 3.6] V in 3V3 application
Linearity error drift	ANG_DERR_{X,Y}Z	-0.9		0.9	Deg.	Angle in XZ or YZ plane, relative to 35 °C, valid for both 5V and 3V3 applications
Intrinsic linearity error	ANG_ERR_XY	-1.0		1.0	Deg.	Angle in XY plane
Intrinsic linearity error	ANG_ERR_{X,Y}Z	-1.5		1.5	Deg.	Angle in XZ or YZ plane
Hysteresis	ANG_HYST		0.1	0.2	Deg.	
Magnetic angular noise <sup>(11)</sup>	ANG_NOISE			0.6	Deg.	10mT, no post-processing filter

*Table 14 – Angular rotary mode performance in limited performance range*



## 9.2. 360 Degree Strayfield Immune Mode

Table 15 below summarizes the MLX90427 360 Degree Strayfield Immune mode performance when operating in the normal performance range defined in Table 12.

Parameter	Symbol	Min	Typ	Max	Unit	Condition
Linearity error drift	ANG_DERR_XY_DBZ	-1.0		1.0	Deg.	Angle in XY plane, relative to 35 °C
Linearity error drift with supply	ANG_DERR_XY_SUP_DBZ	-1.0		1.0	Deg.	Angle in XY plane, relative to 3.3V supply voltage, for supply range in [3.0, 3.6] V in 3V3 application
Output Stray Field Immunity	ANG_ERR_SFI	-0.7		0.7	Deg.	In accordance of ISO 11452-8, at 30 °C, with 10mT/mm magnetic In-plane gradient of In-plane field component, and stray-field strength of 4000A/m from any direction
Intrinsic linearity error	ANG_ERR_XY_DBZ	-1.2		1.2	Deg.	Angle in XY plane
Magnetic angular noise <sup>(11)</sup>	ANG_NOISE_DBZ			0.6	Deg.	10mT/mm up to 125 °C, no post-processing filter
				0.7	Deg.	10mT/mm up to 160 °C, no post-processing filter

Table 15 – 360 Degree Strayfield Immune mode performance

## 9.3. Joystick Mode

Table 15 below summarizes the MLX90427 joystick mode performance when operating in the normal performance range defined in Table 12.

Parameter	Symbol	Min	Typ	Max	Unit	Condition
Linearity error drift	ANG_DERR_JOYSTICK	-0.8		0.8	Deg.	Joystick mode ( $\alpha$ and $\beta$ angles), relative to 35 °C
Intrinsic linearity error	ANG_ERR_XY_JOYSTICK	-2.5		2.5	Deg.	Joystick mode ( $\alpha$ and $\beta$ angles)
Magnetic angular noise <sup>(11)</sup>	ANG_NOISE_JOYSTICK			0.3	Deg.	Joystick mode ( $\alpha$ and $\beta$ angles), 20mT, no post-processing filter

Table 16 – Joystick mode performance

Due to the large distance between sensitive spots (see section 16.2.3), special care must be taken during magnetic design before considering the MLX90427 dual die in Joystick mode. Contact Melexis for further assistance.

## 9.4. Temperature Sensing

The MLX90427 is able to provide a measurement of the absolute temperature. One can get the physical temperature of the die TPHY using the following formula, defined in the SENT standard section A.5.3.2:

$$T_{PHY}[^{\circ}C] = \frac{T_{LIN}}{8} - 73.15$$

where TLIN is the linearized value of the temperature sensor measurement. Table 17 below summarizes the MLX90427 absolute temperature sensing accuracy.

Parameter	Symbol	Min	Typ	Max	Unit	Condition
Absolute temperature sensing accuracy	T_ERR_COLD	-10		10	°C	All error sources included. T<35°C
Absolute temperature sensing accuracy	T_ERR_HOT	-8		8	°C	All error sources included. T>35°C

*Table 17 – Absolute temperature sensing accuracy*

# 10. Serial Interface

The MLX90427 serial interface allows a Master device to operate the position sensor. The MLX90427 interface supports a multiple slave applicative configuration, for which multiple SPI slave devices are connected to the same SPI master device. For more information about frame description, please consult the MLX90427 User Manual.

## 10.1. Interface Timing Specification

Figure 2 illustrates the timing diagram of the interface, and the corresponding timing specification is summarized in Table 18. Note the SPI data rate will be reduced, when the EMC filters are enabled, see the description of the end-user programmable item “NV\_PHY\_RC\_EN” in chapter 12. In this case, all timing specifications in Table 18 will increase by a factor of 5.

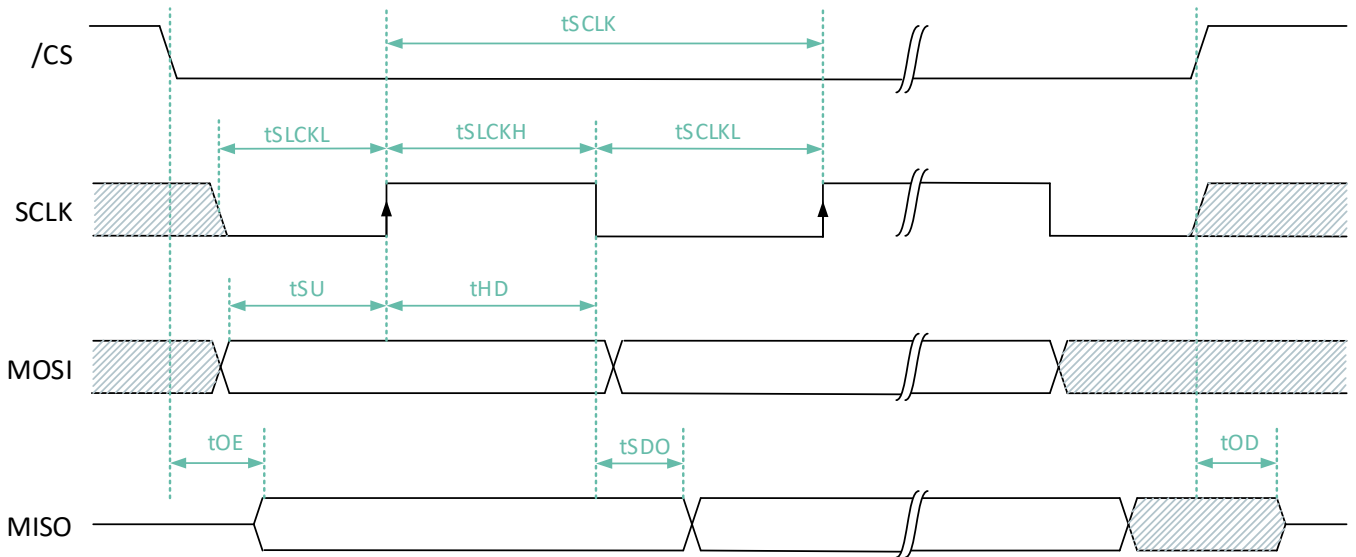

Figure 2 – Serial Interface Timing Diagram

Parameter	Symbol	Min	Max	Unit	Condition
MISO data delay	$t_{SDO}$		40	ns	SCLK falling edge to MISO stable
MOSI hold time	$t_{HD}$	20		ns	/CS and MOSI stable after SCLK falling edge
MOSI setup time	$t_{SU}$	20		ns	/CS, MOSI stable to SCLK rising edge
Output disable delay	$t_{OD}$		100	ns	/CS rising edge to MISO disabled
Output enable delay	$t_{OE}$		100	ns	/CS falling edge to MISO enabled
SCLK high time	$t_{SCLKH}$	40		ns	
SCLK low time	$t_{SCLKL}$	40		ns	
SCLK period	$t_{SCLK}$	100		ns	Time between equal edges of SCLK

Table 18 – SPI interface timing specifications, EMC filters disabled

## 10.2. Trigger Modes

The different trigger modes describe the way the SPI interface shall be used to initiate the acquisition and processing sequences required to return a valid angular position value. The following possible trigger modes are implemented, independently of the detailed protocol implementation:

- **Normal trigger mode:** A normal trigger command initiates an acquisition and processing sequence as soon as possible after the command has been received. The next received SPI command will return the result of the acquisition and processing.
- **Synchronized trigger mode:** This mode operates in the same way as the normal trigger mode, with the difference that a SYNC pulse is expected to start the acquisition and processing sequence after the SPI command has been received. The next received SPI command will return the result of the acquisition and processing sequence. This mode allows to accurately control the sampling instants and latency of the measurements. The latency can be hence partially compensated by using appropriate post-processing in the master device.
- **Synchronized trigger mode with SPI synchronization:** This mode operates in the same way as the synchronized trigger mode, with the difference that the next SPI frame is used as the SYNC event instead of a dedicated SYNC pulse. Supporting this mode does not require any modification to the synchronized trigger mode itself.

## 10.3. Synchronization Function (SYNC)

MLX90427 is able to synchronize the start of the system acquisition cycle on an external synchronization/trigger signal. The synchronization function is implemented as an active-low pulse on the /CS pin. Figure 3 illustrates the timing diagram of the synchronization function, and the corresponding timing specification is summarized in Table 19.

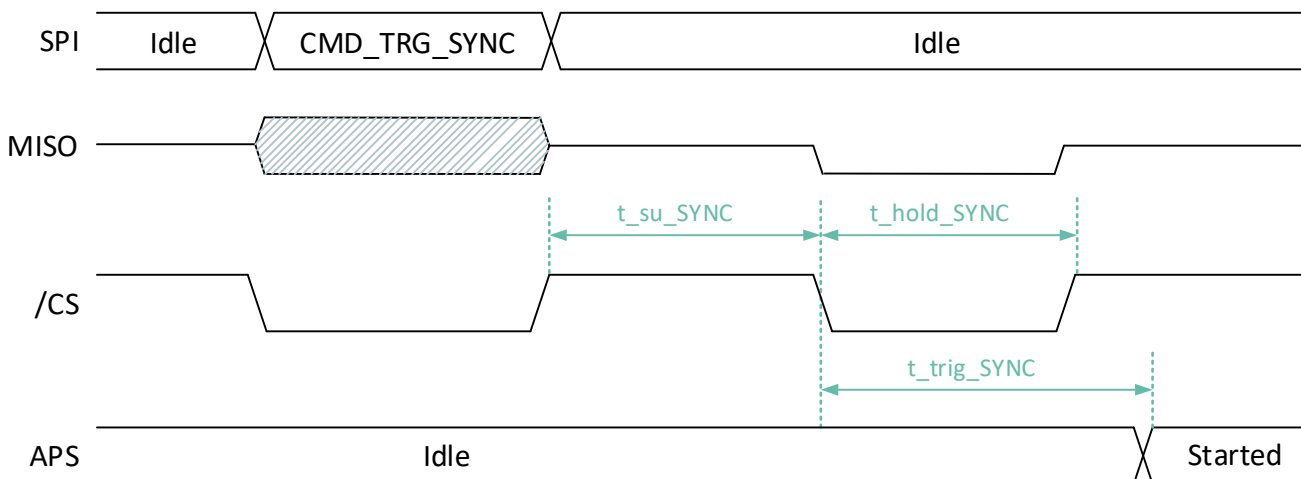

Figure 3 – Synchronization Function Timing Diagram

Parameter	Symbol	Min	Typ	Max	Unit	Condition
SYNC hold time	t_hold_SYNC	20		400	μs	SYNC condition on /CS (pulled down)
SYNC setup time	t_su_SYNC			140	μs	/CS rising edge to SYNC
SYNC latency	t_trig_SYNC	8		14	μs	From SYNC event to acquisition start

Table 19 – Synchronization Function Timing Specifications

## 10.4. Master Interrupt Function

MLX90427 provides a master interrupt function (INT) as a mean to signal a specific event or condition to the master device, which will stay asserted as long as the specified event/condition is true. The interrupt function is implemented as an active-low signal on the /INT pin. Figure 4 illustrates the timing diagram of the interrupt function, and the corresponding timing specification is summarized in Table 20.

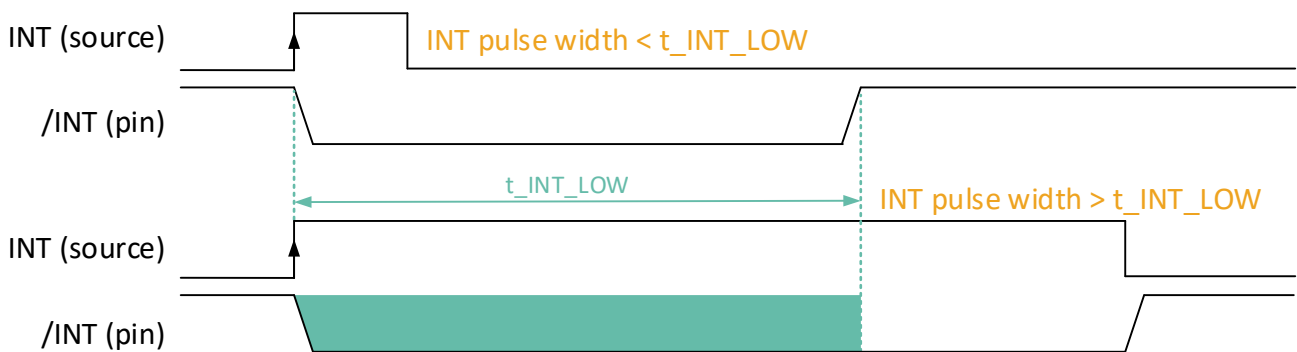

Figure 4 – INT Function Timing Diagram

Parameter	Symbol	Min	Typ	Max	Unit	Condition
Master interrupt signal low time	t_INT_LOW	1		3	ms	Interrupt condition (transient) on /INT pin

Table 20 – INT Function Timing Specifications

## 10.5. SPI Command Overview

The SPI communication protocol of the MLX90427 is listed below in Table 21.

Command	Description	Access	Comments
CMD_GET	Get system info/data/parameter (generic)	NORMAL	
CMD_GET_NEXT	Get system info/data/parameter (generic) Return the next data in a multi-frame GET sequence (depending on selection) or in another specific multi-frame sequence to get extra data	NORMAL	

Command	Description	Access	Comments
CMD_SET	Set system parameter/function (generic)	NORMAL	
CMD_SET_NEXT	Set system parameter/function (generic) Send the next data in a burst SET sequence (depending on selection)	NORMAL	
CMD_NOP	No operation	NORMAL	
CMD_RST	Resets the system (warm reset)	NORMAL	
CMD_STBY	Request to go into standby mode	NORMAL	5V application only <sup>(6)</sup>
CMD_TRG_NORMAL	Triggers and configures a normal acquisition and processing cycle (without SYNC)	NORMAL	
CMD_TRG_SYNC	Triggers and configures a synchronized acquisition and processing cycle	NORMAL	
CMD_MUPET_MODE	Triggers a warm activation of MUPET	NORMAL	
CMD_PROTECTED_MODE	Open a PROTECTED mode session. Activating such a session allows to access the commands with corresponding access level.	NORMAL	
CMD_EXIT	Exit PROTECTED mode session, without system reset.	PROTECTED	
CMD_NVM_RECALL	Trigger NVM recall operation	PROTECTED	
CMD_NVM_STORE	Trigger NVM store operation	PROTECTED	
CMD_READ	Read from system memory	PROTECTED	
CMD_READ_NEXT	Read next value(s) in a burst read sequence	PROTECTED	
CMD_WRITE	Write to system memory	PROTECTED	
CMD_WRITE_NEXT	Write next value(s) in a burst write sequence	PROTECTED	
CMD_RST_PARTIAL	Partial reset - Resets the system but the NVRAM recall in the startup is by-passed such that a temporary NVRAM configuration would be applied to the system at start-up without needing to store it in the NVRAM.	PROTECTED	

*Table 21 – List of the SPI command*

## 10.6. SPI Command Timing Specification

The SPI communication protocol of the MLX90427 is listed below in Table 22.

Parameter	Symbol	Min	Typ	Max	Unit	Condition
CMD_EXIT execution time	t_CMD_EXIT			90	μs	From SPI end-of-frame to result ready
CMD_GET execution time	t_CMD_GET			90	μs	From SPI end-of-frame to result ready
CMD_GET_NEXT execution time	t_CMD_GET_NEXT			90	μs	From SPI end-of-frame to result ready
CMD_NOP execution time	t_CMD_NOP			100	μs	From SPI end-of-frame to result ready
CMD_NVM_RECALL execution time	t_CMD_NVM_RECALL			100	μs	From SPI end-of-frame to result ready
CMD_NVM_STORE execution time	t_CMD_NVM_STORE			13.2	ms	From SPI end-of-frame to result ready
CMD_PROTECTED_MODE execution time	t_CMD_PROTECTED_MODE			100	μs	From SPI end-of-frame to result ready
CMD_READ execution time	t_CMD_READ			110	μs	From SPI end-of-frame to result ready
CMD_READ_NEXT execution time	t_CMD_READ_NEXT			100	μs	From SPI end-of-frame to result ready
CMD_RST_xxx execution time	t_CMD_RST			80	μs	From SPI end-of-frame to warm reset
CMD_SET execution time	t_CMD_SET			120	μs	From SPI end-of-frame to result ready
CMD_STBY execution time	t_CMD_STBY			100	μs	From SPI end-of-frame to standby mode
CMD_TRG_NORMAL(MODE_DBZ) execution time	t_CMD_TRG_DBZ			610	μs	From SPI end-of-frame to result ready
CMD_TRG_NORMAL(MODE_DIAG) execution time	t_CMD_TRG_DIAG			900	μs	From SPI end-of-frame to result ready
CMD_TRG_NORMAL(MODE_DUAL) execution time	t_CMD_TRG_DUAL			900	μs	From SPI end-of-frame to result ready
CMD_TRG_NORMAL(MODE_FDS) execution time	t_CMD_TRG_FDS			940	μs	From SPI end-of-frame to result ready
CMD_TRG_NORMAL(MODE_JOYSTICK) execution time	t_CMD_TRG_JOY			860	μs	From SPI end-of-frame to result ready

Parameter	Symbol	Min	Typ	Max	Unit	Condition
CMD_TRG_NORMAL(MODE_LEG) execution time	t_CMD_TRG_LEG			610	μs	From SPI end-of-frame to result ready
CMD_TRG_SYNC(MODE_DBZ) execution time	t_SYNC_DBZ			520	μs	From SYNC to result ready
CMD_TRG_SYNC(MODE_DIAG) execution time	t_SYNC_DIAG			780	μs	From SYNC to result ready
CMD_TRG_SYNC(MODE_DUAL) execution time	t_SYNC_DUAL			780	μs	From SYNC to result ready
CMD_TRG_SYNC(MODE_LEG) execution time	t_SYNC_LEG			520	μs	From SYNC to result ready
CMD_WRITE execution time	t_CMD_WRITE			110	μs	From SPI end-of-frame to result ready
CMD_WRITE_NEXT execution time	t_CMD_WRITE_NEXT			100	μs	From SPI end-of-frame to result ready
Idle time (EOF to TX re-initialized)	t_idle_SPI		35	40	μs	Idle time between consecutive SPI transactions (/CS rising to falling edges)

Table 22 – SPI command timing specification



## 11. Device Identification Items

Parameter	Description	Width	Offset	
MLX_CHIP_ID0	XPOS_ID	X position on the wafer	8	0
	YPOS_ID	Y position on the wafer	8	8
MLX_CHIP_ID1	WFR_ID	Wafer number	5	0
	LOT_ID[10:0]	Lot number (11 LSBs)	11	5
MLX_CHIP_ID2	LOT_ID[16:11]	Lot number (6 MSBs)	6	0
	FAB_ID	Foundry ID number	4	6
	CORDAT_ID	Internal test database record ID	6	10

*Table 23 – Device Identification Items*

## 12. End-User Programmable Items

### 12.1. Overview

Table 24 provides the list of all the configuration fields in MLX90427's non-volatile memory that are accessible to the end-user to program the device. The corresponding address, width and offset are also shown. The detailed description the configuration fields is described in section 12.2.

Symbol	Description	Address	Width	Offset
NV_DSP_TEMP_CLIP_EN	Enable linearized temperature clipping	0x1000	1	0
NV_DSP_FILTER	Post-processing FIR filter configuration	0x1000	2	1
NV_DSP_REVPOL	Post-processing reverse polarity configuration	0x1000	1	3
NV_DSP_GAIN	Post-processing rescaling function configuration	0x1000	8	4
NV_DSP_GAINMIN	Configure gain diagnostic/clipping (max value)	0x1002	6	0
NV_DSP_GAINMAX	Configure gain diagnostic/clipping (min value)	0x1002	7	6
NV_DSP_GAINSATURATION	Enable gain clipping	0x1002	1	13
NV_DSP_DP	Configure angular reference/discontinuity point post-processing function	0x1004	14	0
NV_DSP_DDP_DBZ	Configure angular reference/discontinuity for angles point post-processing function in the 360 Degree Strayfield Immune mode	0x1006	8	0
NV_DSP_CLAMPLOW	Configure post-processing clamping function (min value)	0x1008	12	0
NV_DSP_CLAMPHIGH	Configure post-processing clamping function (max value)	0x100A	12	0
NV_DIAG_GLOBAL_EN	Enable globally all diagnostics	0x100C	1	0
NV_DIAG_TYPE_WARNING_SS_SEL	Configure safe state for `DIAG_TYPE_WARNING` safety mechanisms	0x100C	1	1
NV_DIAG_TYPE_ERROR_SS_SEL	Configure safe state for `DIAG_TYPE_ERROR` safety mechanisms	0x100C	1	2
NV_DIAG_COLD_SAFE_STARTUP_EN	Enable safe startup after cold power-on	0x100C	1	3
NV_DIAG_HOLD_COUNTER_APS	Configure fault holding for the reporting of `DIAG_EXEC_APS` safety mechanisms	0x100C	3	4

Symbol	Description	Address	Width	Offset
NV_DIAG_HOLD_COUNTER_BT	Configure fault holding for the reporting of `DIAG_EXEC_BT` safety mechanisms	0x100C	3	7
NV_DIAG_SYS_DCT_PERIOD	Configure `DIAG_SYS_DCT` safety mechanism	0x100C	3	10
NV_DIAG_OV_VDD_SEL	Configure `DIAG_OV_VDD` safety mechanism	0x100C	1	13
NV_DIAG_ADC_ERR_EN	Enable `DIAG_ADC_ERR` safety mechanism	0x100E	1	0
NV_DIAG_SYS_ADC_TIME_EN	Enable `DIAG_SYS_ADC_TIME` safety mechanism	0x100E	1	1
NV_DIAG_SYS_APS_TIME_EN	Enable `DIAG_SYS_APS_TIME` safety mechanism	0x100E	1	2
NV_DIAG_DSP_OVF_APS_EN	Enable `DIAG_DSP_OVF_APS` safety mechanism	0x100E	1	3
NV_DIAG_OV_VDD_5V_EN	Enable `DIAG_OV_VDD_5V` safety mechanism	0x100E	1	4
NV_DIAG_UV_VDD_5V_EN	Enable `DIAG_UV_VDD_5V` safety mechanism	0x100E	1	5
NV_DIAG_OV_VDDA_EN	Enable `DIAG_OV_VDDA` safety mechanism	0x100E	1	6
NV_DIAG_UV_VDDA_EN	Enable `DIAG_UV_VDDA` safety mechanism	0x100E	1	7
NV_DIAG_OV_VDDD_EN	Enable `DIAG_OV_VDDD` safety mechanism	0x100E	1	8
NV_DIAG_AFE_HP_DIAG_EN	Enable `DIAG_AFE_HP_DIAG` safety mechanism	0x100E	1	9
NV_DIAG_AFE_HP_DUAL_EN	Enable `DIAG_AFE_HP_DUAL` safety mechanism	0x100E	1	10
NV_DIAG_AFE_AROC_EN	Enable `DIAG_AFE_AROC` safety mechanism	0x1010	1	0
NV_DIAG_AFE_GAIN_EN	Enable `DIAG_AFE_GAIN` safety mechanism	0x1010	1	1
NV_DIAG_AFE_FIELD_MAG_HIGH_EN	Enable `DIAG_AFE_FIELD_MAG_HIGH` safety mechanism	0x1010	1	2
NV_DIAG_AFE_FIELD_MAG_LOW_EN	Enable `DIAG_AFE_FIELD_MAG_LOW` safety mechanism	0x1010	1	3
NV_DIAG_DSP_OVF_BTF_EN	Enable `DIAG_DSP_OVF_BTF` safety mechanism	0x1010	1	4

Symbol	Description	Address	Width	Offset
NV_DIAG_HIGH_TEMP_EN	Enable `DIAG_HIGH_TEMP` safety mechanism	0x1010	1	5
NV_DIAG_LOW_TEMP_EN	Enable `DIAG_LOW_TEMP` safety mechanism	0x1010	1	6
NV_DIAG_ADC_REF_EN	Enable `DIAG_ADC_REF` safety mechanism	0x1010	1	7
NV_DIAG_AFE_TEMP_EN	Enable `DIAG_AFE_TEMP` safety mechanism	0x1010	1	8
NV_DIAG_AFE_TESTBRIDGE_EN	Enable `DIAG_AFE_TESTBRIDGE` safety mechanism	0x1010	1	9
NV_DIAG_SYS_CTM_LEGACY_EN	Enable `DIAG_SYS_CTM_LEGACY` safety mechanism	0x1010	1	11
NV_DIAG_SYS_CTM_DBZ_EN	Enable `DIAG_SYS_CTM_DBZ` safety mechanism	0x1010	1	12
NV_DIAG_SYS_CTM_TEMP_EN	Enable `DIAG_SYS_CTM_TEMP` safety mechanism	0x1010	1	13
NV_DIAG_SYS_DCT_EN	Enable `DIAG_SYS_DCT` safety mechanism	0x1010	1	14
NV_DIAG_ADC_CHECKSUM_EN	Enable `DIAG_ADC_CHECKSUM` safety mechanism	0x1012	1	0
NV_DIAG_ADC_ERR_FATAL_EN	Enable `DIAG_ADC_ERR_FATAL` safety mechanism	0x1012	1	1
NV_DIAG_HW_ADDER_EN	Enable `DIAG_HW_ADDER` safety mechanism	0x1012	1	2
NV_DIAG_SYS_TASK_SEQ_EN	Enable `DIAG_SYS_TASK_SEQ` safety mechanism	0x1012	1	3
NV_DIAG_SYS_TASK_ALIVENESS_EN	Enable `DIAG_SYS_TASK_ALIVENESS` safety mechanism	0x1012	1	4
NV_DIAG_SYS_REGS_EN	Enable `DIAG_SYS_REGS` safety mechanism	0x1012	1	5
NV_DIAG_DSP_ATAN2_EN	Enable `DIAG_DSP_ATAN2` safety mechanism	0x1012	1	6
NV_DIAG_DSP_COPRO_EN	Enable `DIAG_DSP_COPRO` safety mechanism	0x1012	1	7
NV_DIAG_OV_VDD_INT_DIS	Disable master interrupt for `DIAG_OV_VDD` safety mechanism	0x1012	1	8
NV_DIAG_UV_VDD_INT_EN	Enable master interrupt for `DIAG_UV_VDD` safety mechanism	0x1012	1	9
NV_DIAG_OV_VDD3V3_INT_EN	Enable master interrupt for	0x1012	1	10

Symbol	Description	Address	Width	Offset
	`DIAG_OV_VDD3V3` safety mechanism			
NV_DIAG_UV_VDD3V3_INT_EN	Enable master interrupt for `DIAG_UV_VDD3V3` safety mechanism	0x1012	1	11
NV_DIAG_ERROR_INT_EN	Enable master interrupt for `DIAG_TYPE_ERROR` safety mechanisms	0x1012	1	12
NV_DIAG_WARNING_INT_EN	Enable master interrupt for `DIAG_TYPE_WARNING` safety mechanism	0x1012	1	13
NV_DIAG_FATAL_INT_EN	Enable master interrupt for `DIAG_TYPE_FATAL` safety mechanism	0x1012	1	14
NV_DIAG_NVM_CRC_DIS	Disable `DIAG_NVM_CRC_MLX` and `DIAG_NVM_CRC_USER` safety mechanisms	0x1014	8	0
NV_DIAG_RO_CLIP_TIGHT	Configure AROC offset compensation clipping range	0x1014	1	8
NV_DIAG_AFE_TEMP_MARGIN	Configure `DIAG_AFE_TEMP` safety mechanism	0x1016	8	0
NV_DIAG_FIELDTOLOWTHRES	Configure `DIAG_AFE_FIELD_LOW` safety mechanism	0x1016	4	8
NV_DIAG_FIELDTOOHIGHTHRES	Configure `DIAG_AFE_FIELD_HIGH` safety mechanism	0x1016	4	12
NV_DIAG_HP_DIAG_THRESH_MIN	Configure `DIAG_AFE_HP_DIAG` safety mechanism (min threshold)	0x1018	8	0
NV_DIAG_HP_DIAG_THRESH_MAX	Configure `DIAG_AFE_HP_DIAG` safety mechanism (max threshold)	0x1018	8	8
NV_DIAG_HP_DUAL_THRESH_MIN	Configure `DIAG_AFE_HP_DUAL` safety mechanism (min threshold)	0x101A	8	0
NV_DIAG_HP_DUAL_THRESH_MAX	Configure `DIAG_AFE_HP_DUAL` safety mechanism (max threshold)	0x101A	8	8
NV_SYS_MAGNETIC_MODE	Configure supported magnetic mode selection (rotary/linear vs joystick)	0x101C	1	0
NV_SYS_MM_FIELD_MAPPING	Configure magnetic field mapping	0x101C	2	1
NV_SYS_MWD_DEFAULT_EN	Configure master watchdog function behavior at startup	0x101C	1	3
NV_SYS_NVRAM_LOCK	Lock NVRAM for writing and storing	0x101C	1	4
NV_PHY_RC_EN	Enable EMC filter in digital inputs	0x101C	1	8
NV_PHY_MISO_CONFIG	Configure MISO output driver	0x101C	4	9

Symbol	Description	Address	Width	Offset
NV_DSP_PUSHBUTTON_THRESHOLD_HYST	Configure joystick push-button function threshold hysteresis	0x101E	3	0
NV_DSP_PUSHBUTTON_ENABLE	Enable joystick push-button function	0x101E	1	4
NV_DSP_PUSHBUTTON_THRESHOLD	Configure joystick push-button function threshold	0x1020	16	0
NV_DSP_JOY_KT_ALPHA	Configure joystick enhanced angle calculation for angle $\alpha$	0x1022	16	0
NV_DSP_JOY_KT_BETA	Configure joystick enhanced angle calculation for angle $\beta$	0x1024	16	0
NV_DSP_JOY_ENH_ORTH_EN	Enable joystick enhanced orthogonality correction	0x1026	1	0
NV_DSP_JOY_ENH_FORM_EN	Enable joystick enhanced angle calculation	0x1026	1	1
NV_DSP_JOY_S_KZ	Configure joystick enhanced angle calculation	0x1026	8	8
NV_DSP_JOY_K_ORTH_ZX_ALPHA	Configure joystick enhanced orthogonality correction ZX parameter for angle $\alpha$	0x1028	8	0
NV_DSP_JOY_K_ORTH_ZY_ALPHA	Configure joystick enhanced orthogonality correction ZY parameter for angle $\alpha$	0x1028	8	8
NV_DSP_JOY_K_ORTH_ZX_BETA	Configure joystick enhanced orthogonality correction ZX parameter for angle $\beta$	0x102A	8	0
NV_DSP_JOY_K_ORTH_ZY_BETA	Configure joystick enhanced orthogonality correction ZY parameter for angle $\beta$	0x102A	8	8
NV_DSP_JOY_DP_ALPHA	Configure joystick post-processing angular reference/discontinuity point function for angle $\alpha$	0x102C	14	0
NV_DSP_JOY_REVPOL_ALPHA	Configure joystick post-processing reverse polarity function for angle $\alpha$	0x102C	1	14
NV_DSP_JOY_DP_BETA	Configure joystick post-processing angular reference/discontinuity point function for angle $\beta$	0x102E	14	0
NV_DSP_JOY_REVPOL_BETA	Configure joystick post-processing reverse polarity function for angle $\beta$	0x102E	1	14
NV_NVRAM_CRC16_USER	NVM checksum covering user-configurable fields	0x1058	16	0

*Table 24 – List of the end-user programmable items*

## 12.2. Detailed description

This section contains a detailed descriptions of user-configurable system configurability items.

### 12.2.1. System high-level functions

- **NV\_SYS\_MWD\_DEFAULT\_EN** - Master watchdog function at start-up

The configuration field **NV\_SYS\_MWD\_DEFAULT\_EN** can be used to configure the master watchdog function (MWD) behavior at start-up according to the following:

0: The master watchdog does not start on its own at (power-on) start-up (default)

1: The master watchdog function starts on its own at start-up, with the following default configuration; window opening time = 0ms, window closing time = 200ms

Note: The default configuration that applies in case the MWD is enabled at start-up corresponds to a simple timeout watchdog as the window opening time is 0. If the MWD function is enabled at start-up, the following points have to be considered:

The master device will have to either acknowledge, reconfigure or stop the MWD function within 200ms of the beginning of the system start-up phase.

This function does not make any distinction between a start-up and a safe start-up phase, which means that any time that a system warm reset occurs, the 200ms countdown begins.

This also applies when the system wakes up from standby mode.

- **NV\_SYS\_NVRAM\_LOCK** - Non-volatile memory lock

The configuration field **NV\_SYS\_NVRAM\_LOCK** can be used to lock the non-volatile memory against any further writing and/or storing operation according to the following:

0: The NVRAM can be written and stored (with the correct SPI access level configured)

1: The NVRAM is locked and cannot be further written nor stored

Note: It is recommended to use the dedicated SPI command **CMD\_NVM\_STORE** with the **NVM\_LOCK** key in order to perform the locking operation. Note that prior to sending this command, the CRC **NV\_NVRAM\_CRC16\_USER** has to be modified to take into account the fact that the flag **NV\_SYS\_NVRAM\_LOCK** will be set.

## 12.2.2. Physical layer

- **NV\_PHY\_RC\_EN**

The configuration field **NV\_PHY\_RC\_EN** can be used to enable the EMC filters on digital input signals according to the following:

- 0: EMC filters disabled (maximum bandwidth)
- 1: EMC filters enabled (default)

- **NV\_PHY\_MISO\_CONFIG**

The configuration field **NV\_PHY\_MISO\_CONFIG** can be used to configure the MISO driver.

The two LSBs PHY\_MISO\_CONFIG[1:0] can be used to configure the MISO output behavior according to the following:

- 00: Push-pull configuration, low driving force
- 01: Push-pull configuration, strong driving force
- 10: Open-drain configuration, low driving force
- 11: Open-drain configuration, strong driving force

The two LSBs PHY\_MISO\_CONFIG[3:2] can be used to configure the MISO behavior in case of detected supply over-voltage condition, according to the following:

- x0: In case of over-voltage condition, MISO=High-Z (default)
- 01: In case of over-voltage condition, MISO='0'
- 11: In case of over-voltage condition, MISO stays connected to the internal signal (same as if no over-voltage condition)



### 12.2.3. Magnetic modes

- **NV\_SYS\_MAGNETIC\_MODE** - Magnetic mode support

The configuration field **NV\_SYS\_MAGNETIC\_MODE** can be used to configure the supported magnetic modes for the device according to the following:

- 0: Rotary/linear magnetic modes are supported (default)
- 1: Joystick magnetic mode is supported

- **NV\_SYS\_MM\_FIELD\_MAPPING** - Magnetic fields mapping

The configuration field **NV\_SYS\_MM\_FIELD\_MAPPING** can be used to configure the mapping of the measured physical field components to the field components used in the angles calculation, according to the following:

- 00:  $B_0=B_x$ ,  $B_1=B_y$ ,  $B_2=B_z$  (default)
- 01:  $B_0=B_x$ ,  $B_1=B_z$ ,  $B_2=B_y$
- 10:  $B_0=B_y$ ,  $B_1=B_z$ ,  $B_2=B_x$
- 11: Reserved

### 12.2.4. Digital signal processing

The user-configurable items described in this section can be used to modify the system's behavior with regard to its digital signal processing functions. Some of the configuration items also influence some specific diagnostic mechanisms.

- **NV\_DSP\_TEMP\_CLIP\_EN** - Temperature clipping

The configuration field **NV\_DSP\_TEMP\_CLIP\_EN** can be used to enable the clipping of the compensated (linearized) temperature values according to the following:

- 0: Disabled
- 1: The linearized temperature is clipped between **NV\_TRIM\_DIAG\_LOW\_TEMP\_THRES** << 4 and **NV\_TRIM\_DIAG\_HIGH\_TEMP\_THRES** << 4 (default)

Note that the trimming parameters mentioned above that are used to configure the clipping thresholds are not user-configurable and are defined in MLX production line.

- **NV\_DSP\_GAINSATURATION** - Virtual gain clipping

The configuration field **NV\_DSP\_GAINSATURATION** can be used to enable the clipping of the virtual gain as controlled via the automatic gain control (AGC) mechanism, according to the following:

- 0: No gain saturation/clipping (default)
- 1: Gain clipped between **NV\_DSP\_GAINMIN** and **NV\_DSP\_GAINMAX**.

- **NV\_DSP\_GAINMIN** - Gain clipping - Min threshold

The configuration field **NV\_DSP\_GAINMIN** can be used to configure the diagnostic and clipping (if enabled with **NV\_DSP\_GAINSATURATION**) threshold (minimum value) for the virtual gain as controlled via the automatic gain control (AGC) mechanism, according to the following:

0x00: Minimum threshold value (default)

0x3f: Maximum threshold value

- **NV\_DSP\_GAINMAX** - Gain clipping - Max threshold

The configuration field **NV\_DSP\_GAINMAX** can be used to configure the diagnostic and clipping (if enabled with **NV\_DSP\_GAINSATURATION**) threshold (maximum value) for the virtual gain as controlled via the automatic gain control (AGC) mechanism, according to the following:

0x00: Minimum value

0x3f: Maximum value

0x40 to 0x7f: Disabled

Note that for this field, the MSB can be seen as playing the role of a separate disable flag. This allows to use the gain diagnostic only with the minimum threshold if desired.

- **NV\_DSP\_DP** - Angular reference

The configuration field **NV\_DSP\_DP** can be used to configure the angular reference (aka discontinuity point) post-processing function. The angular reference value is defined by this field with the same resolution and encoding as the measurement result angles.

- **NV\_DSP\_DDP\_DBZ** - Angular reference fine adjustment for angle in the 360 Degree Strayfield Immune mode

The configuration field **NV\_DSP\_DDP\_DBZ** can be used to configure the angular reference (aka discontinuity point) post-processing function with a fine adjustment for the 360 Degree Strayfield Immune mode angle measurements. The angular reference that is used for these angles is the sum of **NV\_DSP\_DP** and this field. The angular resolution for this field is the same as the measurement result angles.

- **NV\_DSP\_REVPOL** - Reverse polarity

The configuration field **NV\_DSP\_REVPOL** can be used to configure the post-processing reverse polarity function according to the following:

0: Normal polarity (default)

1: Inverted polarity

- **NV\_DSP\_GAIN - Rescaling**

The configuration field **NV\_DSP\_GAIN** can be used to configure the post-processing rescaling function gain such that the angle is scaled according to the following relationship:

$$y = (x - 180^\circ) \cdot (NV\_DSP\_GAIN + 1)/16 + 180^\circ$$

A value of 15 (default) corresponds to no re-scaling (gain of 1.0). Note that the scaling function is applied with the angle as a signed value, anchored to an angle 180° (the anchor is defined as the angle value that is not affected by the rescaling function).

- **NV\_DSP\_FILTER - Filter**

The configuration field **NV\_DSP\_FILTER** can be used to configure the post-processing FIR filter function according to the following:

0: No filtering (default)

1: Moving average over 2 samples

2: Moving average over 4 samples

3: No filtering

- **NV\_DSP\_CLAMPLOW - Clamping - Min threshold**

The configuration field **NV\_DSP\_CLAMPLOW** can be used to configure the post-processing clamping function<sup>(12)</sup> by defining the minimum angle value with a 12-bit angular resolution.

- **NV\_DSP\_CLAMPHIGH - Clamping - Max threshold**

The configuration field **NV\_DSP\_CLAMPHIGH** can be used to configure the post-processing clamping function<sup>(12)</sup> by defining the maximum angle value with a 12-bit angular resolution.

---

<sup>12</sup> The clamping post-processing function is expected to be applied in the same way for any measured angle (including Joystick mode).

## 12.2.5. Digital signal processing for joystick mode

The configuration fields described in this section allow to configure the digital signal processing that apply to the joystick magnetic modes and functions.

- **NV\_DSP\_PUSHBUTTON\_ENABLE**

The configuration field **NV\_DSP\_PUSHBUTTON\_ENABLE** can be used to enable the joystick push-button function according to the following:

- 0: Joystick push-button function disabled
- 1: Joystick push-button function enabled

- **NV\_DSP\_PUSHBUTTON\_THRESHOLD**

The configuration field **NV\_DSP\_PUSHBUTTON\_THRESHOLD** can be used to configure the joystick push-button function upper threshold. This threshold is applied on the calculated input-referred magnetic field magnitude to determine “if the button is pushed”.

- Format: unsigned, 16-bit
- Fixed-point encoding: UQ16.0, unity=0.1mT

- **NV\_DSP\_PUSHBUTTON\_THRESHOLD\_HYST**

The configuration field **NV\_DSP\_PUSHBUTTON\_THRESHOLD\_HYST** can be used to configure the hysteresis for the joystick push-button function. The hysteresis shall be subtracted from the value defined by **NV\_DSP\_PUSHBUTTON\_THRESHOLD** in order to calculate the lower threshold for the push-button function.

- Format: unsigned, 3-bit
- Fixed-point encoding: UQ13.(-10), unity=0.1mT

- **NV\_DSP\_JOY\_ENH\_FORM\_EN**

The configuration field **NV\_DSP\_JOY\_ENH\_FORM\_EN** can be used to enable the enhanced orthogonality correction for the joystick magnetic mode, according to the following:

0: The normal angle calculation method is used, as described by the equations below:

$$\alpha' = \text{atan2}(K_z \cdot B_2, B_0)$$

$$\beta' = \text{atan2}(K_z \cdot B_2, B_1)$$

1: The enhanced angle calculation method is used, as described by the equations below:

$$\alpha = \text{atan2}(\sqrt{(K_z \cdot B_2)^2 + (K_{TA} \cdot B_1)^2}, B_0)$$

$$\beta = \text{atan2}(\sqrt{(K_z \cdot B_2)^2 + (K_{TA} \cdot B_0)^2}, B_1)$$

- NV\_DSP\_JOY\_KT\_ALPHA

The configuration field **NV\_DSP\_JOY\_KT\_ALPHA** can be used to configure the  $K_{TA}$  parameter for the joystick enhanced angle calculation.

Format: unsigned, 16-bit

Fixed-point encoding: UQ1.15, unity=1.0, possible values are in [0.0, 2.0)

- NV\_DSP\_JOY\_KT\_BETA

The configuration field **NV\_DSP\_JOY\_KT\_BETA** can be used to configure the  $K_{TB}$  parameter for the joystick enhanced angle calculation.

Format: unsigned, 16-bit

Fixed-point encoding: UQ1.15, unity=1.0, possible values are in [0.0, 2.0)

- NV\_DSP\_JOY\_S\_KZ

The configuration field **NV\_DSP\_JOY\_S\_KZ** can be used to configure the  $K_z$  parameter as used in the different joystick angle calculations.

Format: unsigned, 8-bit

Fixed-point encoding: UQ1.7, unity=1.0, possible values are in [0.0, 2.0)

Note: While this parameter has been kept in this product for back-compatibility reasons, note that it is redundant with the IMC gain correction that is already performed during the sensitivity matrix correction pre-processing DSP step.

- NV\_DSP\_JOY\_ENH\_ORTH\_EN

The configuration field **NV\_DSP\_JOY\_ENH\_ORTH\_EN** can be used to enable the enhanced orthogonality correction pre-processing step for the joystick magnetic mode, according to the following:

0: Joystick enhanced orthogonality correction is disabled

1: Joystick enhanced orthogonality correction is enabled; the field components used to calculate the joystick angles are corrected according to the equations below:

$$B_{0,\alpha} = B_0 - K_{\text{orth},ZX,\alpha} \cdot B_2$$

$$B_{1,\alpha} = B_1 - K_{\text{orth},ZY,\alpha} \cdot B_2$$

$$B_{0,\beta} = B_0 - K_{\text{orth},ZX,\beta} \cdot B_2$$

$$B_{1,\beta} = B_1 - K_{\text{orth},ZY,\beta} \cdot B_2$$

- **NV\_DSP\_JOY\_K\_ORTH\_ZX\_ALPHA**

The configuration field **NV\_DSP\_JOY\_K\_ORTH\_ZX\_ALPHA** can be used to configure the value for the  $K_{ORTH,ZX,\alpha}$  parameter used in the enhanced orthogonality correction calculation.

Format: signed, 8-bit

Fixed-point encoding: Q(-1).8, possible values are in [-0.5, 0.5)

- **NV\_DSP\_JOY\_K\_ORTH\_ZY\_ALPHA**

The configuration field **NV\_DSP\_JOY\_K\_ORTH\_ZY\_ALPHA** can be used to configure the value for the  $K_{ORTH,ZY,\alpha}$  parameter used in the enhanced orthogonality correction calculation.

Format: signed, 8-bit

Fixed-point encoding: Q(-1).8, possible values are in [-0.5, 0.5)

- **NV\_DSP\_JOY\_K\_ORTH\_ZX\_BETA**

The configuration field **NV\_DSP\_JOY\_K\_ORTH\_ZX\_BETA** can be used to configure the value for the  $K_{ORTH,ZX,\beta}$  parameter used in the enhanced orthogonality correction calculation.

Format: signed, 8-bit

Fixed-point encoding: Q(-1).8, possible values are in [-0.5, 0.5)

- **NV\_DSP\_JOY\_K\_ORTH\_ZY\_BETA**

The configuration field **NV\_DSP\_JOY\_K\_ORTH\_ZY\_BETA** can be used to configure the value for the  $K_{ORTH,ZY,\beta}$  parameter used in the enhanced orthogonality correction calculation.

Format: signed, 8-bit

Fixed-point encoding: Q(-1).8, possible values are in [-0.5, 0.5)

- **NV\_DSP\_JOY\_DP\_ALPHA**

The configuration field **NV\_DSP\_JOY\_DP\_ALPHA** can be used to configure the angular reference (discontinuity point) for the joystick angles  $\alpha$  or  $\alpha'$ . The configured value is subtracted from the calculated angle as a post-processing step.

Format: signed or unsigned (depending on chosen angular values interpretation), 14-bit

Fixed-point encoding: Q13, unity=180° or UQ14, unity=360°

- **NV\_DSP\_JOY\_DP\_BETA**

The configuration field **NV\_DSP\_JOY\_DP\_BETA** can be used to configure the angular reference (discontinuity point) for the joystick angles  $\beta$  or  $\beta'$ . The configured value is subtracted from the calculated angle as a post-processing step.

Format: signed or unsigned (depending on chosen angular values interpretation), 14-bit  
Fixed-point encoding: Q13, unity=180° or UQ14, unity=360°

- **NV\_DSP\_JOY\_REVPOL\_ALPHA**

The configuration flag **NV\_DSP\_JOY\_REVPOL\_ALPHA** can be used to configure the reverse polarity post-processing function for the joystick angles  $\alpha$  or  $\alpha'$ , according to the following:

0: Normal polarity (default)  
1: Inverted polarity

- **NV\_DSP\_JOY\_REVPOL\_BETA**

The configuration flag **NV\_DSP\_JOY\_REVPOL\_BETA** can be used to configure the reverse polarity post-processing function for the joystick angles  $\beta$  or  $\beta'$ , according to the following:

0: Normal polarity (default)  
1: Inverted polarity

## 12.2.6. Diagnostics (safety mechanisms)

The user-configurable items described in this section can be used to modify the system's behavior with regard to many of its diagnostic safety mechanisms.

- **NV\_DIAG\_GLOBAL\_EN** - Globally enable diagnostics

The configuration flag **NV\_DIAG\_GLOBAL\_EN** can be used to enable/disable globally all the diagnostic safety mechanisms of the system, according to the following:

0: All diagnostics are globally disabled, with the exception of the NVM CRC diagnostics

(DIAG\_NVM\_CRC\_{USER,MLX}) which are not affected by this configuration flag

1: All diagnostics are globally enabled (default)

- **NV\_DIAG\_xxx\_EN** - Individually enable diagnostics

The configuration flags listed below all allow to individually enable, respectively disable diagnostics safety mechanisms, according to the following:

0: The diagnostic and the corresponding reporting are disabled

1: The diagnostic and the corresponding reporting are enabled

- **NV\_DIAG\_ADC\_CHECKSUM\_EN**
- **NV\_DIAG\_ADC\_ERR\_EN**
- **NV\_DIAG\_ADC\_ERR\_FATAL\_EN**
- **NV\_DIAG\_ADC\_REF\_EN**
- **NV\_DIAG\_AFE\_AROC\_EN**
- **NV\_DIAG\_AFE\_FIELD\_MAG\_HIGH\_EN**
- **NV\_DIAG\_AFE\_FIELD\_MAG\_LOW\_EN**
- **NV\_DIAG\_AFE\_GAIN\_EN**
- **NV\_DIAG\_AFE\_HP\_DIAG\_EN**
- **NV\_DIAG\_AFE\_HP\_DUAL\_EN**
- **NV\_DIAG\_AFE\_TEMP\_EN**
- **NV\_DIAG\_AFE\_TESTBRIDGE\_EN**
- **NV\_DIAG\_DSP\_ATAN2\_EN**
- **NV\_DIAG\_DSP\_COPRO\_EN**
- **NV\_DIAG\_DSP\_OVF\_APS\_EN**
- **NV\_DIAG\_DSP\_OVF\_BTF\_EN**
- **NV\_DIAG\_HIGH\_TEMP\_EN**
- **NV\_DIAG\_HW\_ADDER\_EN**
- **NV\_DIAG\_LOW\_TEMP\_EN**
- **NV\_DIAG\_OV\_VDD\_5V\_EN**
- **NV\_DIAG\_OV\_VDDA\_EN**
- **NV\_DIAG\_OV\_VDDD\_EN**



- ***NV\_DIAG\_SYS\_ADC\_TIME\_EN***
- ***NV\_DIAG\_SYS\_APS\_TIME\_EN***
- ***NV\_DIAG\_SYS\_CTM\_DBZ\_EN***
- ***NV\_DIAG\_SYS\_CTM\_LEGACY\_EN***
- ***NV\_DIAG\_SYS\_CTM\_TEMP\_EN***
- ***NV\_DIAG\_SYS\_DCT\_EN***
- ***NV\_DIAG\_SYS\_REGS\_EN***
- ***NV\_DIAG\_SYS\_TASK\_ALIVENESS\_EN***
- ***NV\_DIAG\_SYS\_TASK\_SEQ\_EN***
- ***NV\_DIAG\_UV\_VDD\_5V\_EN***
- ***NV\_DIAG\_UV\_VDDA\_EN***

- **NV\_DIAG\_TYPE\_WARNING\_SS\_SEL** - Safe state for detected warnings

The configuration flag ***NV\_DIAG\_TYPE\_WARNING\_SS\_SEL*** can be used to configure the system's reaction to a fault detected by a safety mechanism of type **DIAG\_TYPE\_WARNING** when returning a measurement result, according to the following:

0: The system returns the measurement results within a **RESULT\_MEAS** SPI frame with a status flag indicating the warning condition (safe state **SS4**) (default)

1: The system returns an error frame **ERR\_DIAG** with a detailed indication of the detected fault(s) within its **DIAGS\_STATE** field (safe state **SS1**)

- **NV\_DIAG\_TYPE\_ERROR\_SS\_SEL** - Safe state for detected errors

The configuration flag ***NV\_DIAG\_TYPE\_ERROR\_SS\_SEL*** can be used to configure the system's reaction to a fault detected by a safety mechanism of type **DIAG\_TYPE\_ERROR** when returning a measurement result, according to the following:

0: The system returns the measurement results within a **RESULT\_MEAS** SPI frame with a status flag indicating the error condition (safe state **SS2**) (default)

1: The system returns an error frame **ERR\_DIAG** with a detailed indication of the detected fault(s) within its **DIAGS\_STATE** field (safe state **SS1**)

- **NV\_DIAG\_COLD\_SAFE\_STARTUP\_EN** - Safe startup at power-on

The configuration field ***NV\_DIAG\_COLD\_SAFE\_STARTUP\_EN*** can be used to enable the system to start with a safe startup phase instead of the usual normal startup phase, according to the following:

0: Normal start-up after power-on reset (default)

1: Safe start-up after power-on reset

- **NV\_DIAG\_HOLD\_COUNTER\_APS - Fault holding counter**

The configuration field **NV\_DIAG\_HOLD\_COUNTER\_APS** can be used to configure the fault holding mechanism applied to diagnostics that are scheduled for execution at each acquisition and processing sequence (DIAG\_EXEC\_APS scheduling), according to the following:

0: Fault holding disabled; the next time that the diagnostic is executed without fault, the error state is released at once,

1 to 7: The diagnostic needs to be repeated a number of times corresponding to the configuration value in order for the error state to be released.

- **NV\_DIAG\_HOLD\_COUNTER\_BT - Fault holding counter**

The configuration field **NV\_DIAG\_HOLD\_COUNTER\_BT** can be used to configure the fault holding mechanism applied to diagnostics that are scheduled for execution within background tasks (DIAG\_EXEC\_BT scheduling), according to the following:

0: Fault holding disabled; the next time that the diagnostic is executed without fault, the error state is released at once,

1 to 7: The diagnostic needs to be repeated a number of times corresponding to the configuration value in order for the error state to be released.

- **NV\_DIAG\_SYS\_DCT\_PERIOD - Diagnostic cycle time monitoring period**

The configuration field **NV\_DIAG\_SYS\_DCT\_PERIOD** can be used to configure the diagnostic cycle time monitoring safety mechanism (DIAG\_SYS\_DCT) period, according to the following:

0: 5 ms

1: 10 ms

2: 20 ms

3: 40 ms

4: 80 ms

5: 160 ms

6: 320 ms

7: 640 ms

- **NV\_DIAG\_OV\_VDD\_SEL - Supply over-voltage**

The configuration flag **NV\_DIAG\_OV\_VDD\_SEL** can be used to configure the supply over-voltage monitoring thresholds according to the following:

0: Normal thresholds (default)

1: Tight thresholds

- **NV\_DIAG\_NVM\_CRC\_DIS - Disable NVM CRC verification**

The configuration field **NV\_DIAG\_NVM\_CRC\_DIS** can be used to disable the regular checking of the NVM CRC values (DIAG\_NVM\_CRC\_MLX and DIAG\_NVM\_CRC\_USER) within the system global diagnostic cycle, according to the following:

0x31: The regular verification of the NVM CRC checksums is disabled

Any other value: The regular verification of the NVM CRC checksums is enabled (default = 0x00)

Note: Even if this flag is set, the CRC values will be verified and have to be correct prior that the NVM can be stored using the CMD\_NVM\_STORE SPI command (DIAG\_SYS\_NVM\_STORE\_INIT safety mechanism).

- **NV\_DIAG\_RO\_CLIP\_TIGHT - AROC clipping range**

The configuration field **NV\_DIAG\_RO\_CLIP\_TIGHT** can be used to configure the rough offset compensation (AROC) clipping range and associated diagnostic DIAG\_AFE\_AROC, according to the following:

0: The AROC compensation control value is clipped within the range [0, 127] (default)

1: The AROC compensation control value is clipped within the range [8, 122]

- **NV\_DIAG\_AFE\_TEMP\_MARGIN - Temperature sensor diagnostic**

The configuration field **NV\_DIAG\_AFE\_TEMP\_MARGIN** can be used to configure the comparison margin that is used for the DIAG\_AFE\_TEMP diagnostic, according to the following:

$$\begin{aligned} \Delta T &= |T_1 + T_2 - 16384| \\ \Delta T_{\max} &= 2 \cdot NV\_DIAG\_AFE\_TEMP\_MARGIN \end{aligned}$$

If  $\Delta T \leq \Delta T_{\max}$ , the diagnostic is considered as passing (no fault detected).

The measurement  $T_2$  is measured with the diagnostic temperature sensor output having its differential output signal's polarity reversed compared to measurement  $T_1$ , such that it is expected that the sum of both measurements should stay constant. This is why the diagnostic's assessment is performed by summing both measurement values. Note that both sensors temperature values  $T_1$  and  $T_2$  are truncated to 14-bit resolution (the LSB from the initial 15-bit measurement is dropped).

- **NV\_DIAG\_FIELDTOOLOWTHRES - Magnetic field magnitude diagnostic**

The configuration field **NV\_DIAG\_FIELDTOOLOWTHRES** can be used to configure the threshold to apply for the low magnetic field magnitude diagnostic DIAG\_AFE\_FIELD\_MAG\_LOW threshold, according to the following:

0 to 15: Threshold value with a resolution of 2mT/LSB and no offset;

$$\begin{aligned} B_{\text{low}} &= 2 \cdot NV\_DIAG\_FIELDTOOLOWTHRES \\ B_{\text{low}} &\in [0,30] \text{ mT} \end{aligned}$$

- **NV\_DIAG\_FIELDTOOHIGHTHRES** - Magnetic field magnitude diagnostic

The configuration field **NV\_DIAG\_FIELDTOOHIGHTHRES** can be used to configure the threshold to apply for the high magnetic field magnitude diagnostic DIAG\_AFE\_FIELD\_MAG\_HIGH threshold, according to the following:

0 to 15: Threshold value with a resolution of 4mT/LSB and a 70mT offset;

$$B_{\text{high}} = 70 + 4 \cdot \text{NV\_DIAG\_FIELDTOOLOWTHRES}$$

$$B_{\text{high}} \in [70, 130] \text{ mT}$$

- **NV\_DIAG\_HP\_DIAG\_THRESH\_MIN** - Diagnostic magnetic mode

The configuration field **NV\_DIAG\_HP\_DIAG\_THRESH\_MIN** can be used to configure the lowest acceptable difference between the angular values of the DIAG\_AFE\_HP\_DIAG safety mechanism with a resolution of 1LSB = 0.352°. With the chosen encoding, the possible span for the configured thresholds goes from -45.0° to +44.65°. Note that the expected systematic, nominal angle difference of 13.6° is separately accounted for and compensated. Default: -7.5° (0xeb)

- **NV\_DIAG\_HP\_DIAG\_THRESH\_MAX** - Diagnostic magnetic mode

The configuration field **NV\_DIAG\_HP\_DIAG\_THRESH\_MAX** can be used to configure the highest acceptable difference between the angular values of the DIAG\_AFE\_HP\_DIAG safety mechanism with a resolution of 1LSB = 0.352°. With the chosen encoding, the possible span for the configured thresholds goes from -45.0° to +44.65°. Note that the expected systematic, nominal angle difference of 13.6° is separately accounted for and compensated. Default: 7.5° (0x15)

- **NV\_DIAG\_HP\_DUAL\_THRESH\_MIN** - Dual magnetic mode

The configuration field **NV\_DIAG\_HP\_DUAL\_THRESH\_MIN** can be used to configure the lowest acceptable difference between the angular values of the DIAG\_AFE\_HP\_DUAL safety mechanism with a resolution of 1LSB = 0.352°. With the chosen encoding, the possible span for the configured thresholds goes from -45.0° to +44.65°. Note that the expected systematic, nominal angle difference of -45° is separately accounted for and compensated. Default: -7.5° (0xeb)

- **NV\_DIAG\_HP\_DUAL\_THRESH\_MAX** - Dual magnetic mode

The configuration field **NV\_DIAG\_HP\_DUAL\_THRESH\_MAX** can be used to configure the highest acceptable difference between the angular values of the DIAG\_AFE\_HP\_DUAL safety mechanism with a resolution of 1LSB = 0.352°. With the chosen encoding, the possible span for the configured thresholds goes from -45.0° to +44.65°. Note that the expected systematic, nominal angle difference of -45° is separately accounted for and compensated. Default: 7.5° (0x15)

## 12.2.7. Master interrupt function

- **NV\_DIAG\_OV\_VDD\_INT\_DIS** - Disable supply over-voltage interrupt

The configuration field **NV\_DIAG\_OV\_VDD\_INT\_DIS** can be used to prevent the master interrupt to be triggered in case of a detected supply over-voltage condition according to the following:

0: A supply over-voltage condition triggers a master interrupt (default)

1: A supply over-voltage condition does not trigger a master interrupt

Note: The supply over-voltage monitoring is an HW master interrupt source. A master interrupt may therefore occur even if the corresponding SW fault reporting mechanism does not report it.

- **NV\_DIAG\_UV\_VDD\_INT\_EN** - Enable supply under-voltage interrupt

The configuration field **NV\_DIAG\_UV\_VDD\_INT\_EN** can be used to enable the master interrupt to be triggered in case of a detected supply under-voltage condition, according to the following:

0: A supply under-voltage condition does not trigger a master interrupt (default)

1: A supply under-voltage condition triggers a master interrupt

Note: The supply under-voltage monitoring is an HW master interrupt source. A master interrupt may therefore occur even if the corresponding SW fault reporting mechanism does not report it.

- **NV\_DIAG\_OV\_VDD3V3\_INT\_EN** - Enable 3.3V supply over-voltage interrupt

The configuration field **NV\_DIAG\_OV\_VDD3V3\_INT\_EN** can be used to enable the master interrupt to be triggered in case of a detected 3.3V supply over-voltage condition, according to the following:

0: A 3.3V supply over-voltage condition does not trigger a master interrupt (default)

1: A 3.3V supply over-voltage condition triggers a master interrupt

Note: The 3.3V supply over-voltage monitoring is an HW master interrupt source. A master interrupt may therefore occur even if the corresponding SW fault reporting mechanism does not report it.

- **NV\_DIAG\_UV\_VDD3V3\_INT\_EN** - Enable 3.3V supply under-voltage interrupt

The configuration field **NV\_DIAG\_UV\_VDD3V3\_INT\_EN** can be used to enable the master interrupt to be triggered in case of a detected 3.3V supply under-voltage condition, according to the following:

0: A 3.3V supply under-voltage condition does not trigger a master interrupt (default)

1: A 3.3V supply under-voltage condition triggers a master interrupt

Note: The 3.3V supply under-voltage monitoring is an HW master interrupt source. A master interrupt may therefore occur even if the corresponding SW fault reporting mechanism does not report it.

- **NV\_DIAG\_ERROR\_INT\_EN** - Error interrupt

The configuration field **NV\_DIAG\_ERROR\_INT\_EN** can be used to enable the master interrupt to be triggered in case of any detected DIAG\_TYPE\_ERROR fault by the corresponding safety mechanisms, according to the following:

- 0: A DIAG\_TYPE\_ERROR fault does not trigger a master interrupt (default)
- 1: A DIAG\_TYPE\_ERROR fault triggers a master interrupt

- **NV\_DIAG\_WARNING\_INT\_EN** - Error interrupt

The configuration field **NV\_DIAG\_WARNING\_INT\_EN** can be used to enable the master interrupt to be triggered in case of any detected DIAG\_TYPE\_WARNING fault by the corresponding safety mechanisms, according to the following:

- 0: A DIAG\_TYPE\_WARNING fault does not trigger a master interrupt (default)
- 1: A DIAG\_TYPE\_WARNING fault triggers a master interrupt

- **NV\_DIAG\_FATAL\_INT\_EN** - Error interrupt

The configuration field **NV\_DIAG\_FATAL\_INT\_EN** can be used to enable the master interrupt to be triggered in case of any detected DIAG\_TYPE\_FATAL fault by the corresponding safety mechanisms, according to the following:

- 0: A DIAG\_TYPE\_FATAL fault does not trigger a master interrupt (default)
- 1: A DIAG\_TYPE\_FATAL fault triggers a master interrupt

## 12.2.8. Checksum

- **NV\_NVRAM\_CRC16\_USER** - Cyclic redundancy checksum

The field **NV\_NVRAM\_CRC16\_USER** contains a 16-bit cyclic redundancy checksum (CRC) that covers NVM user page full content, calculated according to the parameters defined in the section NVM cyclic redundancy checksum.

This configuration field marks the highest address for the USER page. Any NVM configuration with an address beyond this belongs to the Melexis (MLX) page and should not be overwritten in application.

## 13. Safety Mechanisms

The MLX90427 provides numerous self-diagnostic features, i.e., safety mechanisms. Those features increase the robustness of the IC functionality either by preventing the IC from providing an erroneous output signal or by reporting the failure according to the protocol definition. An overview of the safety mechanisms in MLX90427 is listed in Table 25. Please refer to the MLX90427 safety manual for the corresponding detailed information.

Symbol	Description	Type
DIAG_ADC_REF	ADC self test (reference test points)	DIAG_TYPE_ERROR
DIAG_AFE_TEMP	Temperature sensors comparison check	DIAG_TYPE_ERROR
DIAG_AFE_TESTBRIDGE	AFE testbridge diagnostic (reference test points)	DIAG_TYPE_ERROR
DIAG_ADC_ERR	ADC error flags check	DIAG_TYPE_ERROR
DIAG_AFE_HP_DIAG	Diagnostic rotary magnetic mode comparison check	DIAG_TYPE_ERROR
DIAG_AFE_HP_DUAL	Dual-mode rotary magnetic mode comparison check	DIAG_TYPE_ERROR
DIAG_AFE_AROC	Automatic rough offset correction (AROC) consistency check	DIAG_TYPE_ERROR
DIAG_AFE_GAIN	Automatic gain control (AGC) consistency check	DIAG_TYPE_ERROR
DIAG_AFE_FIELD_MAG_HIGH	Field magnitude monitor (too high magnitude)	DIAG_TYPE_ERROR
DIAG_AFE_FIELD_MAG_LOW	Field magnitude monitor (too low magnitude)	DIAG_TYPE_ERROR
DIAG_ADC_CHECKSUM	ADC interface (SDATA, ADATA) checksum	DIAG_TYPE_FATAL (SW)
DIAG_ADC_ERR_FATAL	ADC (fatal) error flags check	DIAG_TYPE_FATAL (SW)
DIAG_COM_READ_TIME	TRG-to-READ timing monitoring	DIAG_TYPE_ERROR
DIAG_COM_SYNC_TIME	SYNC-to-SYNC timing monitoring	DIAG_TYPE_ERROR
DIAG_COM_FRAME	Frame transmission error check	DIAG_TYPE_ERROR
DIAG_COM_CRC	Communication (SPI) CRC check	DIAG_TYPE_ERROR
DIAG_COM_OPC	Communication (SPI) opcode check	DIAG_TYPE_ERROR
DIAG_COM_ACCESS	Communication (SPI) access level check	DIAG_TYPE_ERROR
DIAG_COM_ARGS	Communication (SPI) command arguments check	DIAG_TYPE_ERROR
DIAG_COM_KEY	Communication (SPI) key (argument) check	DIAG_TYPE_ERROR
DIAG_COM_RDY	Check if the system is ready to receive a communication	DIAG_TYPE_ERROR
DIAG_COM_STATE	Check if the system state allows to receive a specific command.	DIAG_TYPE_ERROR

Symbol	Description	Type
DIAG_SYS_ADC_TIME	ADC sequence timing monitor (TRG-to-EOS)	DIAG_TYPE_ERROR
DIAG_SYS_APS_TIME	APS sequence timing monitor (TRG-to-End of DSP)	DIAG_TYPE_ERROR
DIAG_CPU_DMAERR	MLX16 DMA error	DIAG_TYPE_FATAL (HW)
DIAG_CPU_MEMERR	MLX16 invalid address error/memory error	DIAG_TYPE_FATAL (HW)
DIAG_CPU_OPERR	MLX16 program error (wrong opcode)	DIAG_TYPE_FATAL (HW)
DIAG_CPU_STACKERR	MLX16 stack error	DIAG_TYPE_FATAL (HW)
DIAG_CPU_PROTERR	MLX16 protection error	DIAG_TYPE_FATAL (HW)
DIAG_SYS_ADC_DROP	ADC drop mechanism	DIAG_TYPE_ERROR
DIAG_SYS_AWD	Absolute watchdog (AWD)	DIAG_TYPE_FATAL (HW)
DIAG_HW_ADDER	ADATA adder diagnostics	DIAG_TYPE_FATAL (SW)
DIAG_SYS_TASK_SEQ	Task sequence monitor	DIAG_TYPE_FATAL (SW)
DIAG_SYS_TASK_ALIVENESS	Task aliveness monitor	DIAG_TYPE_FATAL (SW)
DIAG_SYS_REGS	Critical IO ports monitoring	DIAG_TYPE_FATAL (SW)
DIAG_SYS_NVM_STORE_INIT	NVM store request initialization check	DIAG_TYPE_ERROR
DIAG_SYS_NVM_STORE	NVM store request access callback check	DIAG_TYPE_FATAL (SW)
DIAG_SYS_MODE_CTRL	Mode control diagnostic	DIAG_TYPE_FATAL (SW)
DIAG_SYS_CTM_LEGACY	Cycle time monitoring for AGC and AROC calculation for legacy acquisition	DIAG_TYPE_WARNING
DIAG_SYS_CTM_DBZ	Cycle time monitoring for AGC and AROC calculation for acquisition in the 360 Degree Strayfield Immune mode	DIAG_TYPE_WARNING
DIAG_SYS_CTM_TEMP	Cycle time monitoring for temperature compensation calculation	DIAG_TYPE_WARNING
DIAG_SYS_DCT	Diagnostic cycle time monitoring	DIAG_TYPE_WARNING
DIAG_DSP_OVF	DSP overflow (prevention & detection)	DIAG_TYPE_ERROR
DIAG_DSP_ATAN2	DSP Test Pattern (atan2)	DIAG_TYPE_FATAL (SW)
DIAG_DSP_COPRO	Co-processor test	DIAG_TYPE_FATAL (SW)
DIAG_OV_VDD_5V	VDD overvoltage monitor	DIAG_TYPE_ERROR
DIAG_UV_VDD_5V	VDD undervoltage monitor	DIAG_TYPE_ERROR
DIAG_HIGH_TEMP	Over-temperature monitor	DIAG_TYPE_ERROR
DIAG_LOW_TEMP	Under-temperature monitor	DIAG_TYPE_ERROR



Symbol	Description	Type
DIAG_OV_VDD_STBY	VDD standby overvoltage monitor	N/A
DIAG_NVM_CRC_MLX	NVRAM checksum - MLX page	DIAG_TYPE_FATAL (SW)
DIAG_NVM_ECC	NVRAM ECC	DIAG_TYPE_FATAL (HW)
DIAG_RAM_BIST	RAM March-C BIST	DIAG_TYPE_FATAL (HW)
DIAG_RAM_PARITY	RAM parity	DIAG_TYPE_FATAL (HW)
DIAG_ROM_PARITY	ROM parity	DIAG_TYPE_FATAL (HW)
DIAG_NVM_CRC_USER	NVRAM checksum - User page	DIAG_TYPE_FATAL (SW)
DIAG_OV_VDDA	VDDA overvoltage monitor	DIAG_TYPE_ERROR
DIAG_UV_VDDA	VDDA undervoltage monitor	DIAG_TYPE_ERROR
DIAG_OV_VDDD	VDDD overvoltage monitor	DIAG_TYPE_ERROR
DIAG_UV_VDDD	VDDD undervoltage monitor - Power-on reset	N/A
DIAG_UV_VAUX	VAUX power-on reset (VAUX_PORB)	N/A

*Table 25 – List of MLX90427 self-diagnostic features*

The types of the self-diagnostic presented in Table 25 are explained as follows:

- Fatal faults:** The type DIAG\_TYPE\_FATAL refers to faults and associated self-diagnostic(s) that lead to not being able to fully trust the proper execution of the system's embedded software. This type of faults/diagnostics are labelled as being "fatal" and are reacted to with a warm reset of the system, followed by a safe startup sequence (safe state SS7). Permanent faults will make the system stay permanently in safe mode (safe state SS7). This type of faults can originate from both a hardware (HW) or software (SW) source.
- Errors:** The type DIAG\_TYPE\_ERROR refers to faults and associated self-diagnostic(s) that lead to not being able to trust the measured fields and/or resulting calculated angles. This type of faults/diagnostics are reported by using one of the safe states SS2/SS3 or optionally SS1.
- Warnings:** The type DIAG\_TYPE\_WARNING refers to self-diagnostic(s) being able to cover latent faults. This type of faults/diagnostics are reacted to by using the safe state SS4, or optionally SS1.

## 14. Recommended Application Diagrams

### 14.1. Recommended Application Diagram for SOIC-8 Package

#### 14.1.1. MLX90427 in SOIC-8 Package and 5V Application

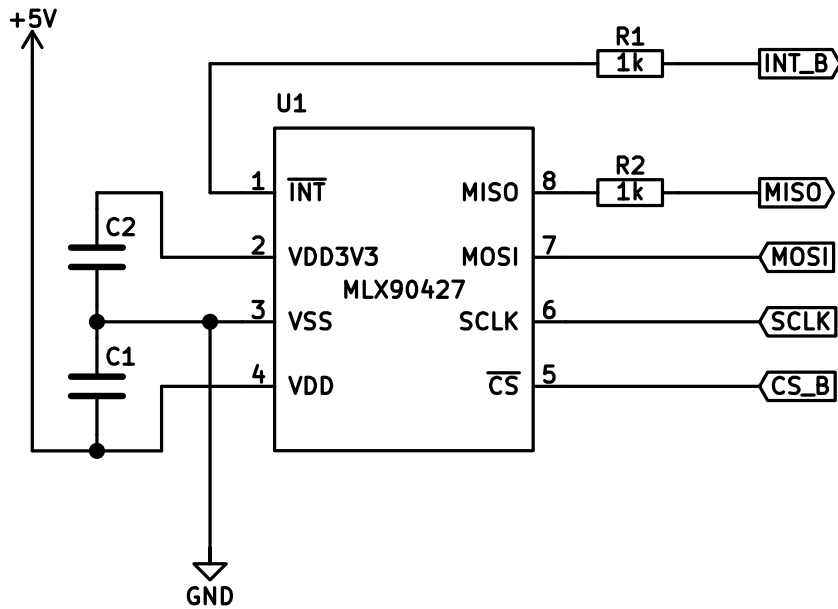

Figure 5 – Recommended wiring for the MLX90427 in SOIC-8 package and 5V application

#### 14.1.2. MLX90427 in SOIC-8 Package and 3V3 Application

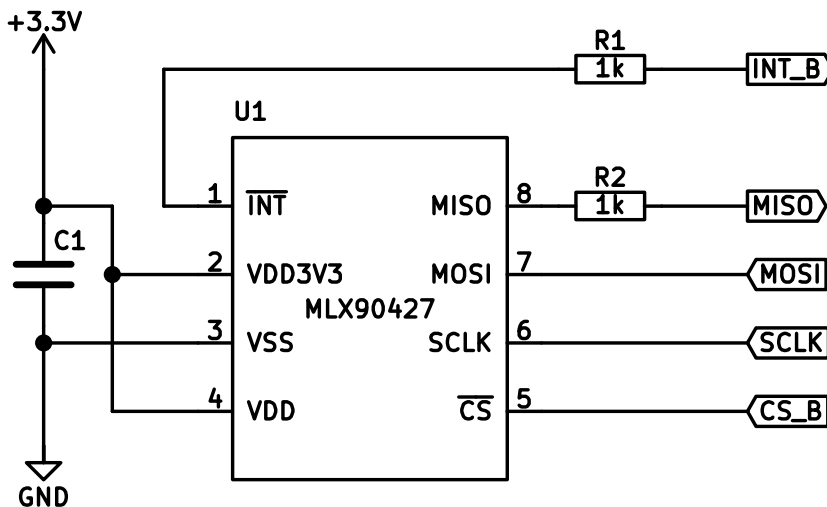

Figure 6 – Recommended wiring for the MLX90427 in SOIC-8 package and 3V3 application

Table 26 shows the recommended component values for the MLX90727 application diagrams of SOIC-8 package in Figure 5 and Figure 6.

Component	Min	Typ	Max	Comment
C1	100nF	220nF	-	Close to the IC pin
C2	100nF	100nF	220nF	Close to the IC pin
R1	--	1kΩ	1.2kΩ	Optional
R2	--	1kΩ	1.2kΩ	Optional

*Table 26 – Recommended Component Values for the MLX90427 in SOIC-8 Package*

## 14.2. Recommended Application Diagram for TSSOP-16 Package

### 14.2.1. MLX90427 in TSSOP-16 Package and 5V Application

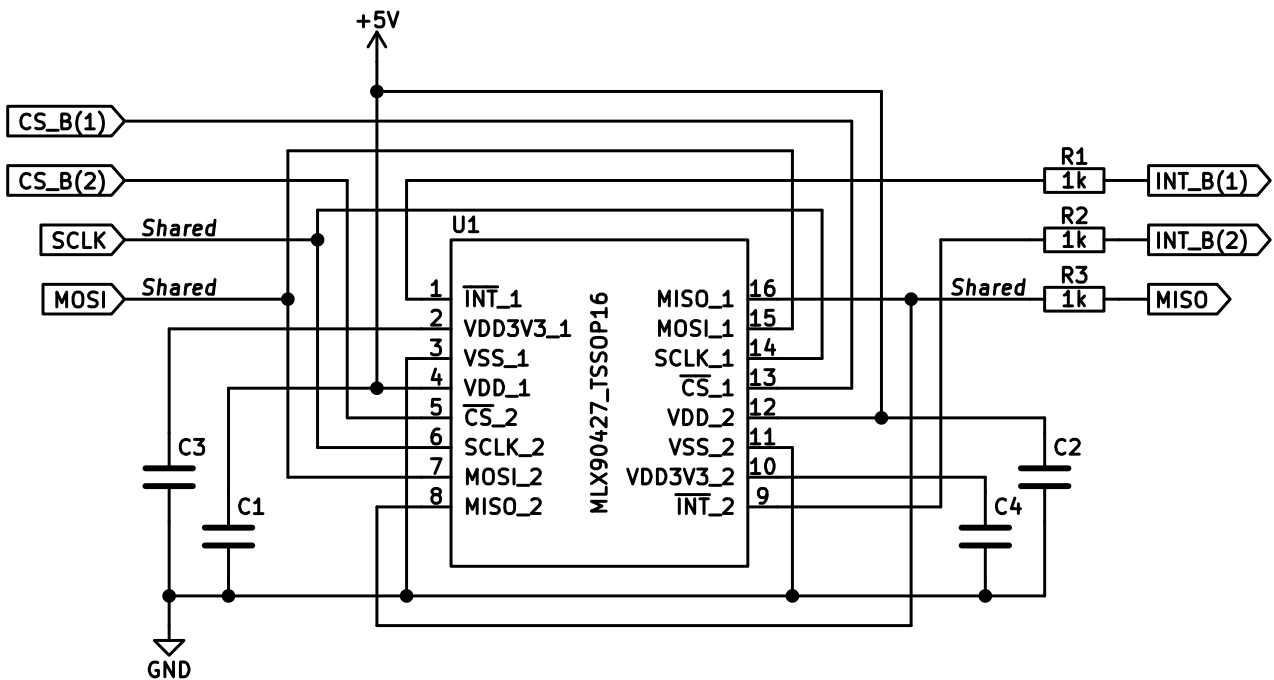

*Figure 7 – Recommended wiring for the MLX90427 in TSSOP-16 package and 5V application*

### 14.2.2. MLX90427 in TSSOP-16 Package and 3V3 Application

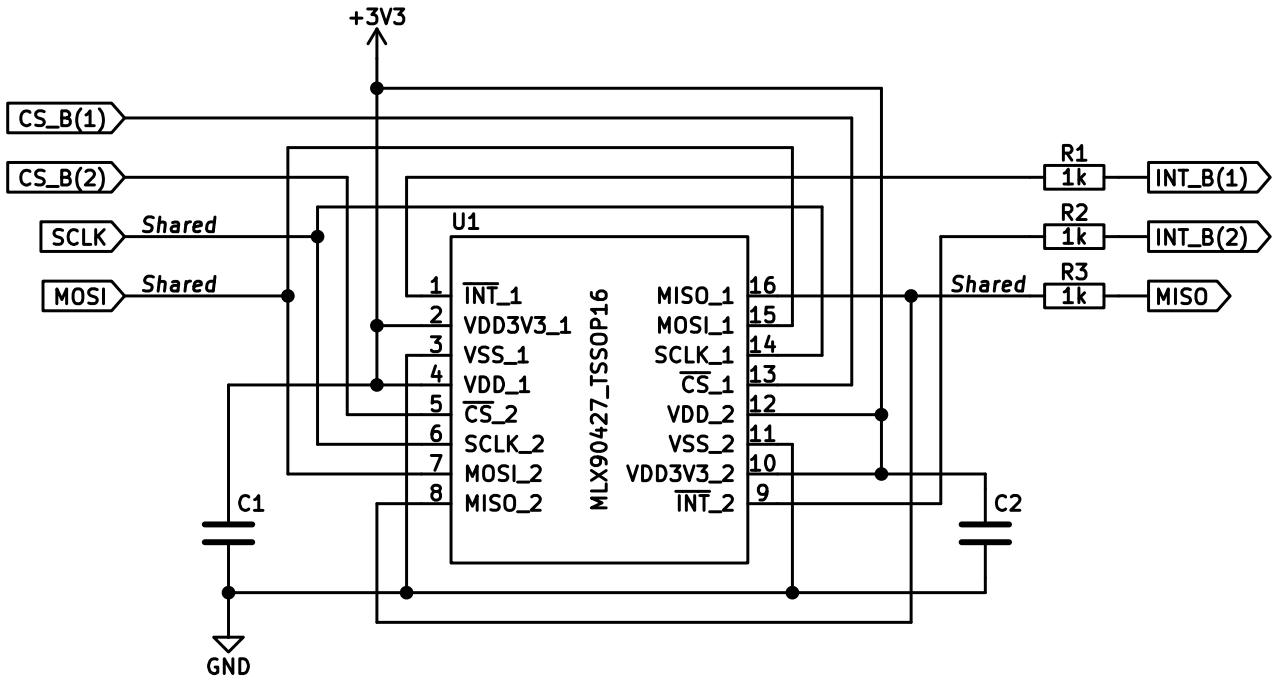

Figure 8 – Recommended wiring for the MLX90427 in TSSOP-16 package and 3V3 application

Table 27 shows the recommended component values for the MLX90727 application diagrams of TSSOP-16 package in Figure 7 and Figure 8.

Component	Min	Typ	Max	Comment
C1, C2	100nF	220nF	-	Close to the IC pin, could be merged in a single capacitor depending on layout
C1, C2	680nF	-	-	In 3.3V supply configuration mode, if needed to support higher EMC immunity ratings on VDD
C3, C4	100nF	100nF	220nF	Close to the IC pin
R1, R2, R3	--	1kΩ	1.2kΩ	Optional

Table 27 – Recommended Component Values for the MLX90427 in TSSOP-16 Package

## 15. IC Handling and Assembly

### 15.1. Storage and Handling of Plastic Encapsulated ICs

Plastic encapsulated ICs shall be stored and handled according to their MSL categorization level (specified in the packing label) as per J-STD-033.

Electronic semiconductor products are sensitive to Electro Static Discharge (ESD). The component assembly shall be handled in EPA (Electrostatic Protected Area) as per ANSI S20.20.

For more information refer to Melexis [Guidelines for storage and handling of plastic encapsulated ICs](#) <sup>(13)</sup>.

### 15.2. Assembly of Encapsulated ICs

For Surface Mounted Devices (SMD, as defined according to JEDEC norms), the only applicable soldering method is reflow.

Melexis products soldering on PCB should be conducted according to the requirements of IPC/JEDEC and J-STD-001. Solder quality acceptance should follow the requirements of IPC-A-610.

Environmental protection of customer assembly with Melexis products for harsh media application, is applicable by means of coating, potting or overmolding considering restrictions listed in the relevant application notes <sup>(13)</sup>.

For other specific process, contact Melexis via [www.melexis.com/technical-inquiry](http://www.melexis.com/technical-inquiry).

### 15.3. Environment and Sustainability

Melexis is contributing to global environmental conservation by promoting non-hazardous solutions. For more information on our environmental policy and declarations (RoHS, REACH...) visit [www.melexis.com/environmental-forms-and-declarations](http://www.melexis.com/environmental-forms-and-declarations).

---

<sup>13</sup> [www.melexis.com/ic-handling-and-assembly](http://www.melexis.com/ic-handling-and-assembly)

## 16. Package Information

### 16.1. SOIC-8 Package

#### 16.1.1. SOIC-8 – Package Dimensions

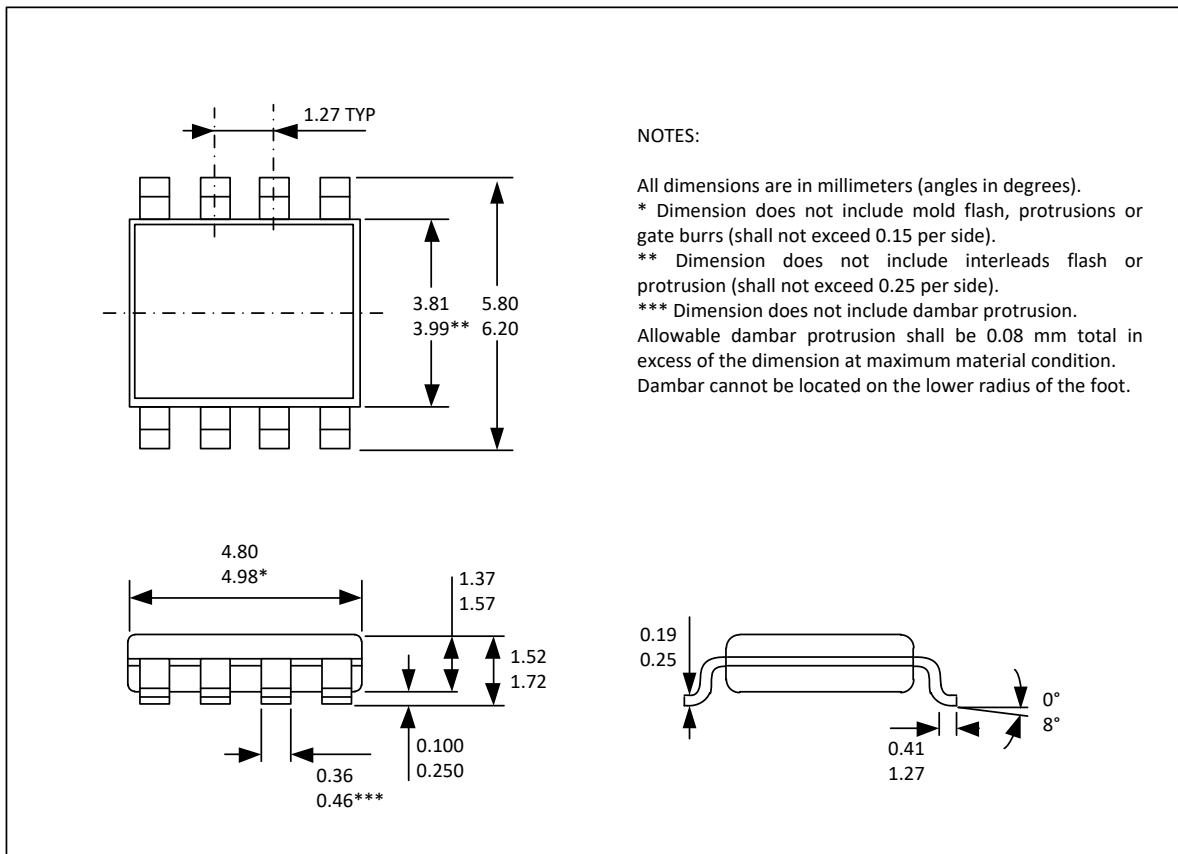

**NOTES:**

All dimensions are in millimeters (angles in degrees).  
 \* Dimension does not include mold flash, protrusions or gate burrs (shall not exceed 0.15 per side).  
 \*\* Dimension does not include interleads flash or protrusion (shall not exceed 0.25 per side).  
 \*\*\* Dimension does not include dambar protrusion. Allowable dambar protrusion shall be 0.08 mm total in excess of the dimension at maximum material condition. Dambar cannot be located on the lower radius of the foot.

Figure 9 – SOIC-8 Package Outline Drawing

### 16.1.2. SOIC-8 – Pinout and Marking

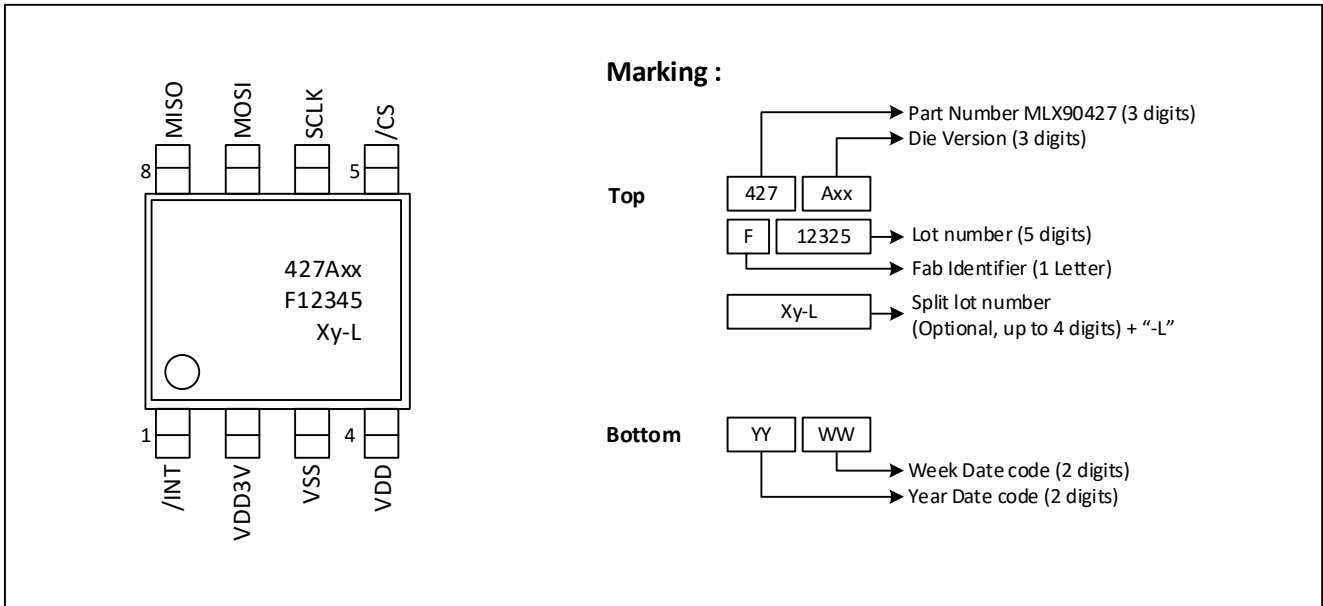

Figure 10 – SOIC-8 Pinout and Marking

### 16.1.3. SOIC-8 – Magnetic Sensitive Spot Positioning

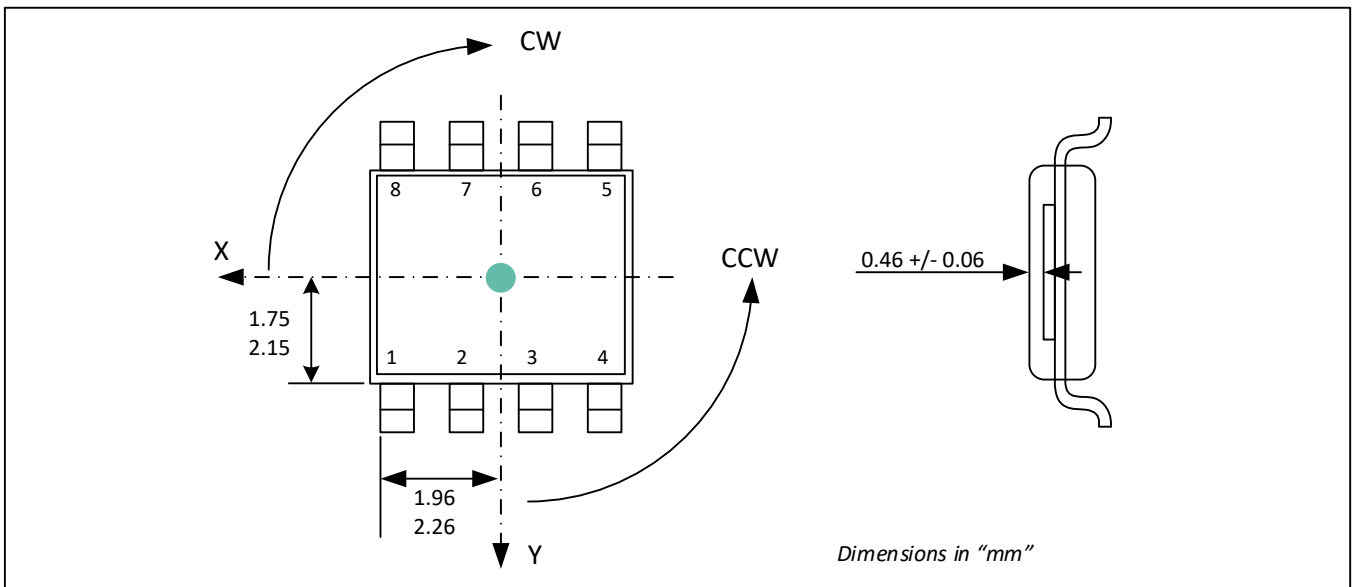
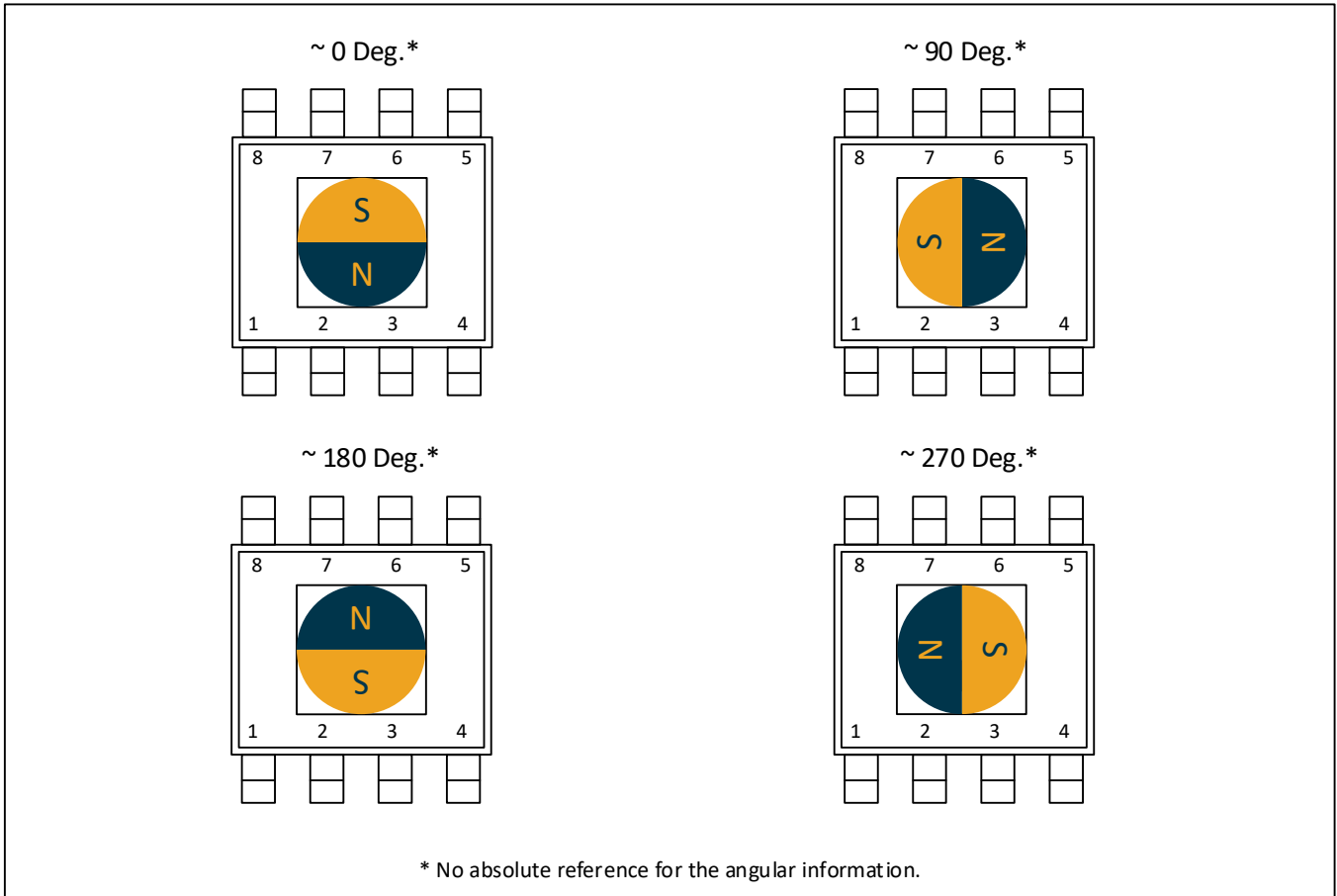

Figure 11 – SOIC-8 Magnetic Sensitive Spot Positioning

### 16.1.4. SOIC-8 – Angle Detection



*Figure 12 – SOIC-8 Angle Detection*

The MLX90427 is an absolute angular position sensor, but the intrinsic linearity error (see chapter 9) does not include the error linked to the absolute reference 0 Deg.



## 16.2. TSSOP-16 Package

### 16.2.1. TSSOP-16 – Package Dimensions

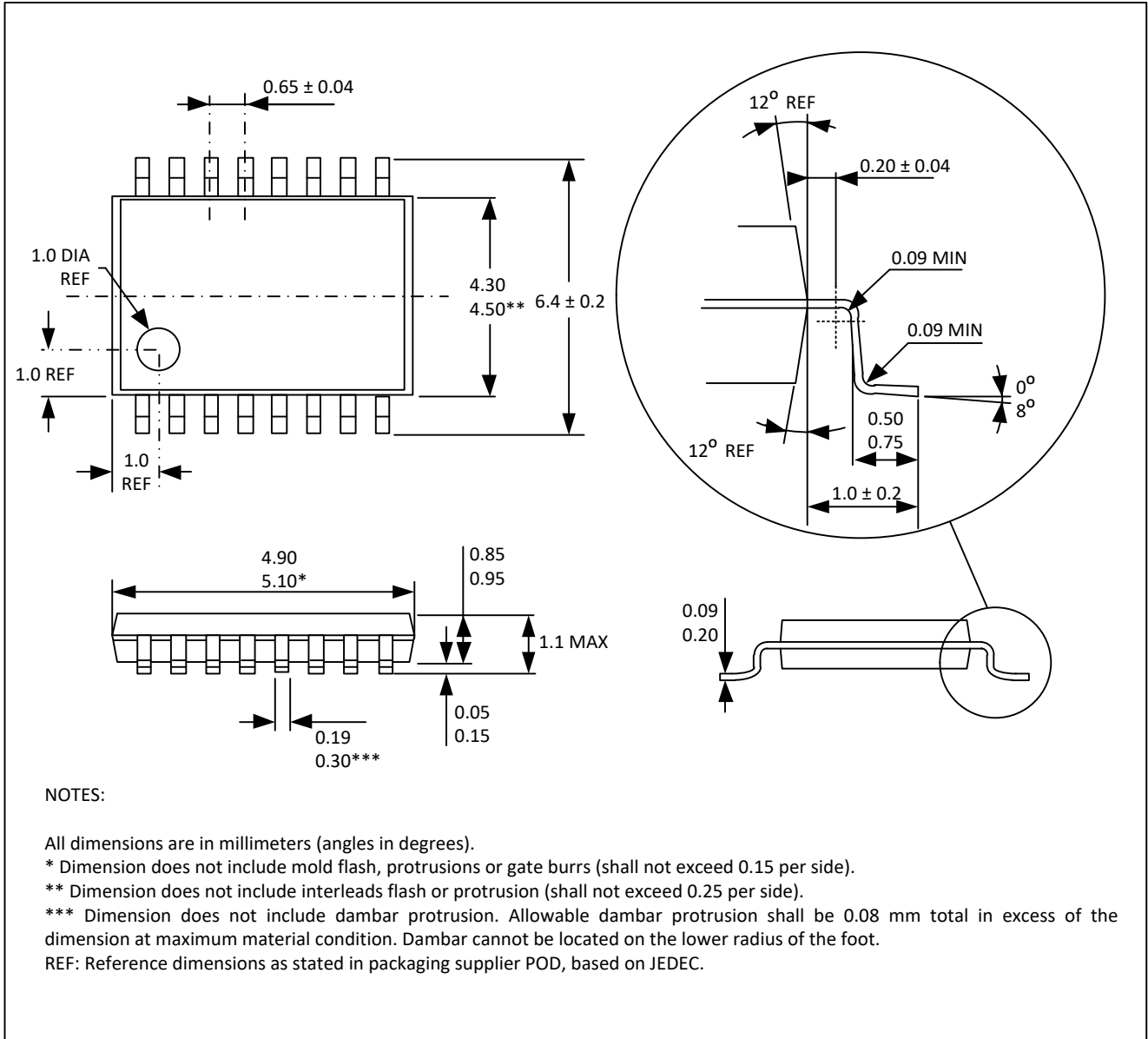

Figure 13 – TSSOP-16 Package Outline Dimensions

### 16.2.2. TSSOP-16 – Pinout and Marking

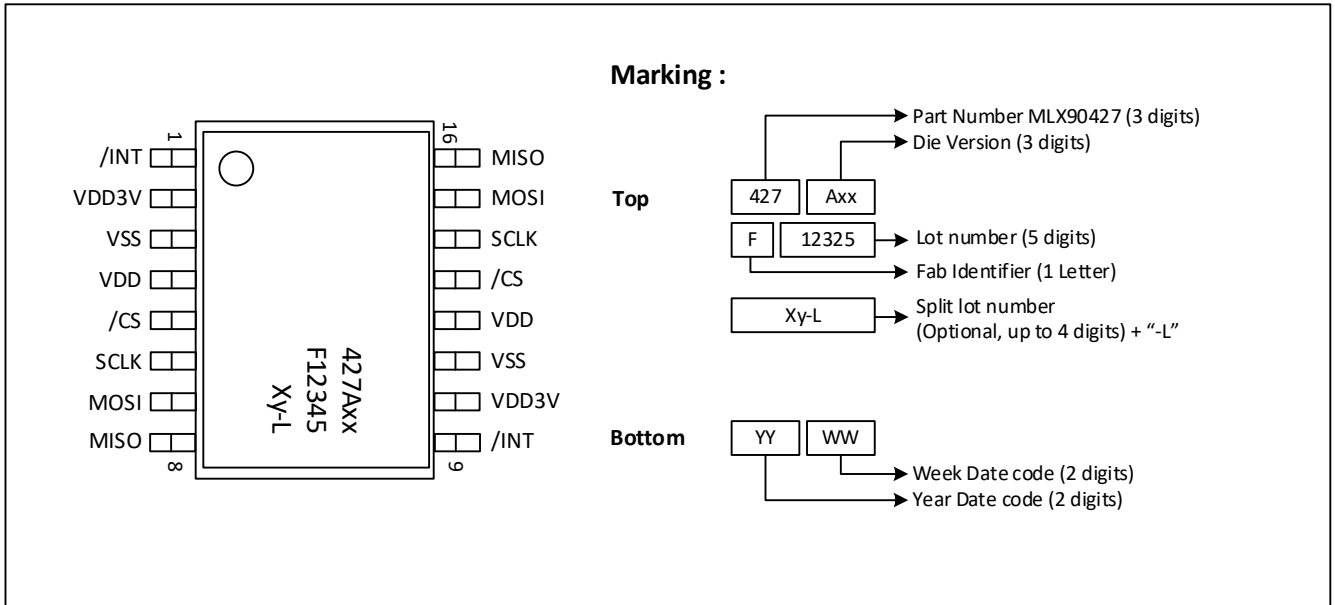

Figure 14 – TSSOP-16 Dual-Die Package Pinout and Marking

### 16.2.3. TSSOP-16 – Sensitive spot positioning

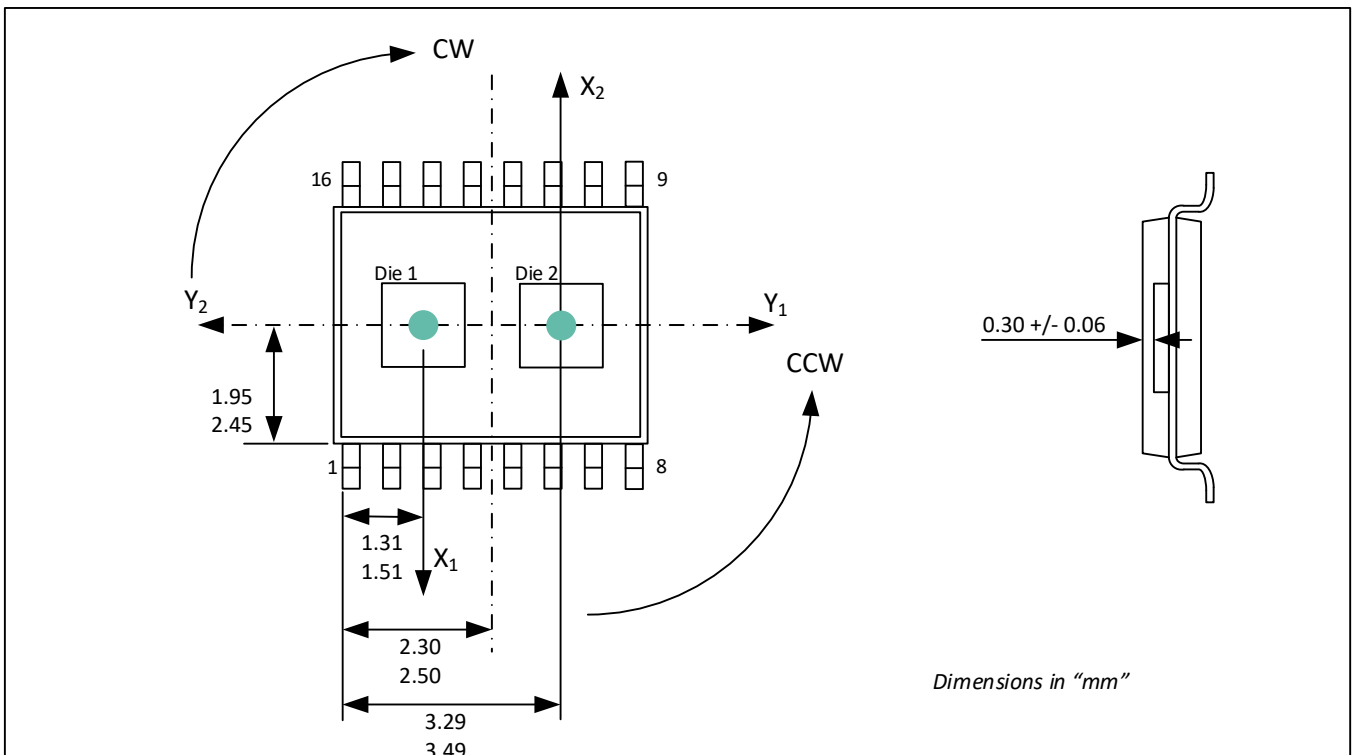

Figure 15 – TSSOP-16 dual-die package Sensitive Spot Position

### 16.2.4. TSSOP-16 – Angle Detection

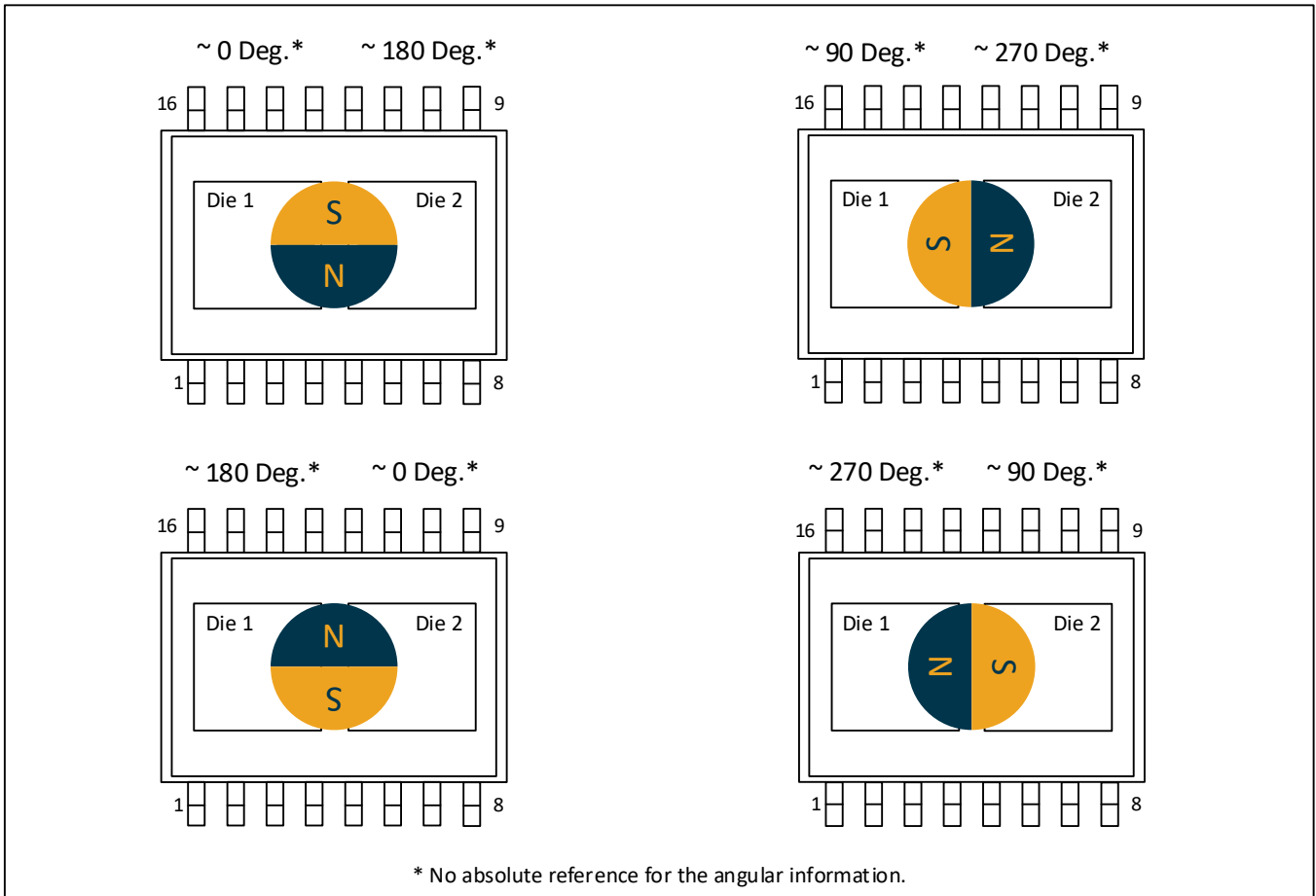

Figure 16 – TSSOP-16 Angle Detection

The MLX90427 is an absolute angular position sensor, but the intrinsic linearity error (see chapter 9) does not include the error linked to the absolute reference 0 Deg.

## 17. Contact

For the latest version of this document, go to our website at [www.melexis.com](http://www.melexis.com).

For additional information, please contact our Direct Sales team and get help for your specific needs:

Europe, Africa	Email : sales_europe@melexis.com
Americas	Email : sales_usa@melexis.com
Asia	Email : sales_asia@melexis.com

## 18. Disclaimer

*The content of this document is believed to be correct and accurate. However, the content of this document is furnished "as is" for informational use only and no representation, nor warranty is provided by Melexis about its accuracy, nor about the results of its implementation. Melexis assumes no responsibility or liability for any errors or inaccuracies that may appear in this document. Customer will follow the practices contained in this document under its sole responsibility. This documentation is in fact provided without warranty, term, or condition of any kind, either implied or expressed, including but not limited to warranties of merchantability, satisfactory quality, non-infringement, and fitness for purpose. Melexis, its employees and agents and its affiliates' and their employees and agents will not be responsible for any loss, however arising, from the use of, or reliance on this document. Notwithstanding the foregoing, contractual obligations expressly undertaken in writing by Melexis prevail over this disclaimer.*

*This document is subject to change without notice, and should not be construed as a commitment by Melexis. Therefore, before placing orders or prior to designing the product into a system, users or any third party should obtain the latest version of the relevant information.*

*Users or any third party must determine the suitability of the product described in this document for its application, including the level of reliability required and determine whether it is fit for a particular purpose.*

*This document as well as the product here described may be subject to export control regulations. Be aware that export might require a prior authorization from competent authorities. The product is not designed, authorized or warranted to be suitable in applications requiring extended temperature range and/or unusual environmental requirements. High reliability applications, such as medical life-support or life-sustaining equipment or avionics application are specifically excluded by Melexis. The product may not be used for the following applications subject to export control regulations: the development, production, processing, operation, maintenance, storage, recognition or proliferation of:*

- 1. chemical, biological or nuclear weapons, or for the development, production, maintenance or storage of missiles for such weapons;*
- 2. civil firearms, including spare parts or ammunition for such arms;*
- 3. defense related products, or other material for military use or for law enforcement;*
- 4. any applications that, alone or in combination with other goods, substances or organisms could cause serious harm to persons or goods and that can be used as a means of violence in an armed conflict or any similar violent situation.*

*No license nor any other right or interest is granted to any of Melexis' or third party's intellectual property rights.*

*If this document is marked "restricted" or with similar words, or if in any case the content of this document is to be reasonably understood as being confidential, the recipient of this document shall not communicate, nor disclose to any third party, any part of the document without Melexis' express written consent. The recipient shall take all necessary measures to apply and preserve the confidential character of the document. In particular, the recipient shall (i) hold document in confidence with at least the same degree of care by which it maintains the confidentiality of its own proprietary and confidential information, but no less than reasonable care; (ii) restrict the disclosure of the document solely to its employees for the purpose for which this document was received, on a strictly need to know basis and providing that such persons to whom the document is disclosed are bound by confidentiality terms substantially similar to those in this disclaimer; (iii) use the document only in connection with the purpose for which this document was received, and reproduce document only to the extent necessary for such purposes; (iv) not use the document for commercial purposes or to the detriment of Melexis or its customers. The confidentiality obligations set forth in this disclaimer will have indefinite duration and in any case they will be effective for no less than 10 years from the receipt of this document.*

*This disclaimer will be governed by and construed in accordance with Belgian law and any disputes relating to this disclaimer will be subject to the exclusive jurisdiction of the courts of Brussels, Belgium.*

*The invalidity or ineffectiveness of any of the provisions of this disclaimer does not affect the validity or effectiveness of the other provisions. The previous versions of this document are repealed.*

*Melexis © - No part of this document may be reproduced without the prior written consent of Melexis. (2024)*

*IATF 16949 and ISO 14001 Certified*