

ISS.	AMEND	DATE
1	ISSUED	16/02/21

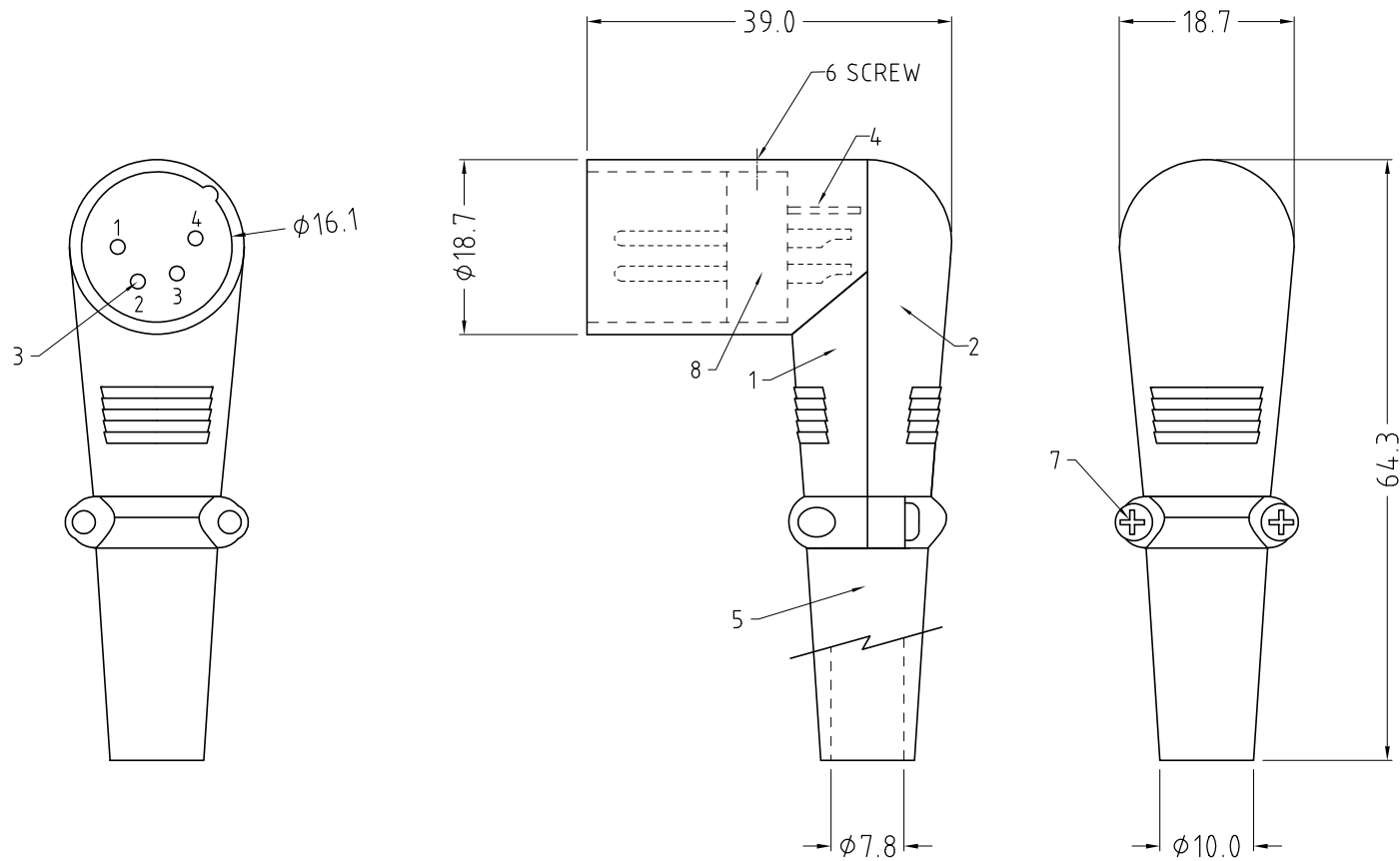

4 POLE MALE

ITEM	DESCRIPTION	MATERIAL	FINISH	QTY
1	BODY (FRONT)	ZINC ALLOY	NICKEL PLATE	1
2	BODY (REAR)	ZINC ALLOY	NICKEL PLATE	1
3	CONTACTS	BRASS	SILVER PLATE	4
4	EARTH CONTACT	STEEL	TIN PLATE	1
5	GROMMET	PVC	BLACK	1
6	TOP SCREW	STEEL	NICKEL PLATE	1
7	SCREW	STEEL	NICKEL PLATE	2
8	INSERT	PBT	GREY	1

**NOTE**

Contact Resistance:  $\approx 5m\Omega$   
 Insulation Resistance:  $\approx 5000M\Omega$   
 Withstand Voltage: 1400V  
 Durability (Mating / Unmating):  $\approx 2000$   
 Insertion and Extraction Force: 10-80N

**RoHS**  
**COMPLIANT**

**TOLERANCE**  
 NO DEC. PLACE  $\pm$   
 1 DEC. PLACE  $\pm$   
 2 DEC. PLACE  $\pm$   
 HOLE  $\varnothing \pm$   
 ANGLES  $\pm$   
 UNLESS OTHERWISE STATED

DO NOT SCALE

**Cliff Electronic Components Ltd.**

76 Holmethorpe Avenue, Holmethorpe Industrial Estate,  
 Redhill, Surrey, RH1 2PF, England, UK  
 Tel: 01737-771375 Fax: 01737-766012 Website: www.cliffuk.co.uk

DIMENSIONS IN MILLIMETERS UNLESS OTHERWISE STATED. WORK TO DIMENSIONS. REMOVE ALL BURRS. IF IN DOUBT ASK.

3rd ANGLE PROJECTION:

MATERIAL: SEE TABLE

FINISH: SEE TABLE

DRAWN: T.J.O.

APPROVED: D.P.J.

TITLE: AUDIO PLUG 4APM/MRA 4 POLE MALE

DRWG. No. **FC60964N**

FORM: A4DRWGH