

ISS.	AMEND	DATE
1	ISSUED	11/02/21

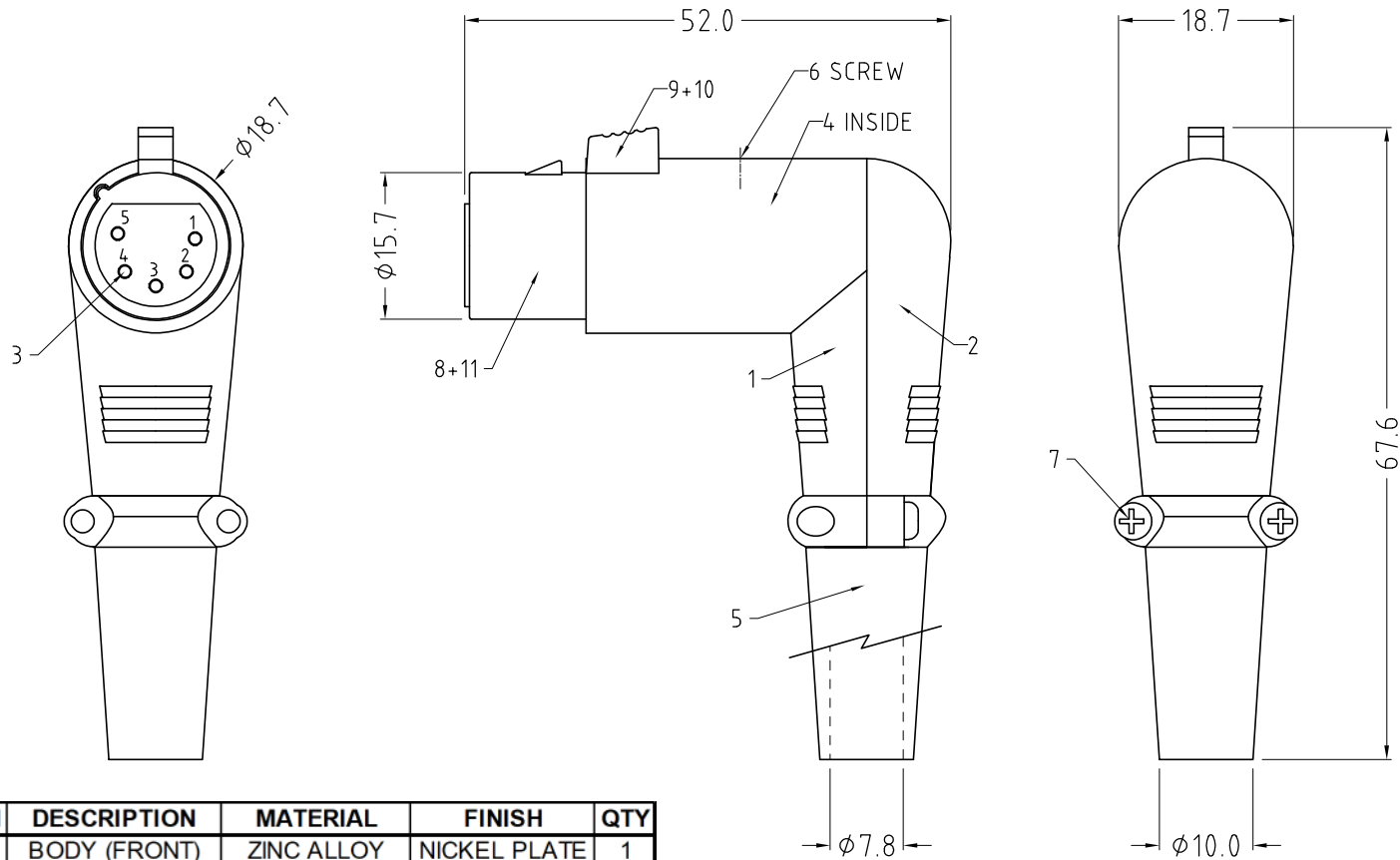

5 POLE FEMALE

ITEM	DESCRIPTION	MATERIAL	FINISH	QTY
1	BODY (FRONT)	ZINC ALLOY	NICKEL PLATE	1
2	BODY (REAR)	ZINC ALLOY	NICKEL PLATE	1
3	CONTACTS	BRASS	SILVER PLATE	5
4	EARTH CONTACT	STEEL	TIN PLATE	1
5	GROMMET	PVC	BLACK	1
6	TOP SCREW	STEEL	NICKEL PLATE	1
7	SCREW	STEEL	NICKEL PLATE	2
8	INSERT	PBT	GREY	1
9	BUTTON	ZINC ALLOY	NICKEL PLATE	1
10	SPRING	SPRING STEEL	BLACK	1
11	CASING	BRASS	NICKEL PLATE	1

NOTE

Contact Resistance: $\approx 5m\Omega$
 Insulation Resistance: $\approx 5000M\Omega$
 Withstand Voltage: 1400V
 Durability (Mating / Unmating): ≈ 2000
 Insertion and Extraction Force: 10-80N

RoHS
COMPLIANT

TOLERANCE
 NO DEC. PLACE \pm
 1 DEC. PLACE \pm
 2 DEC. PLACE \pm
 HOLE $\varnothing \pm$
 ANGLES \pm
 UNLESS OTHERWISE STATED

DO NOT SCALE

Cliff Electronic Components Ltd.

76 Holmethorpe Avenue, Holmethorpe Industrial Estate,
 Redhill, Surrey, RH1 2PF, England, UK
 Tel: 01737-771375 Fax: 01737-766012 Website: www.cliffuk.co.uk

DIMENSIONS IN MILLIMETERS UNLESS OTHERWISE STATED. WORK TO DIMENSIONS. REMOVE ALL BURRS. IF IN DOUBT ASK.

3rd ANGLE PROJECTION:

MATERIAL: SEE TABLE

FINISH: SEE TABLE

DRAWN: T.J.O.

APPROVED: D.P.J.

TITLE: AUDIO PLUG 5APF/MRA 5 POLE FEMALE

DRWG. No. **FC60955N**

FORM: A4DRWGH