

BC556/BC557/BC558

TRANSISTOR(PNP)

FEATURE

- High Voltage
- Complement to BC546, BC547, BC548



Package TO-92

MAXIMUM RATINGS* ($T_a=25^{\circ}\text{C}$ unless otherwise noted)

Parameter	Symbol	Value	UNIT
Collector-Base Voltage	BC556	-80	V
	BC557	-50	
	BC558	-30	
Collector-Emitter Voltage	BC556	-65	V
	BC557	-45	
	BC558	-30	
Emitter-Base Voltage	V_{EBO}	-5	V
Collector Current - Continuous	I_C	-0.1	A
Collector Power Dissipation	P_C	625	mW
Thermal Resistance from Junction to Ambient	$R_{\theta JA}$	200	$^{\circ}\text{C}/\text{W}$
Junction Temperature	T_J	150	$^{\circ}\text{C}$
Junction and Storage Temperature	T_{stg}	-55~+150	$^{\circ}\text{C}$

*These ratings are limiting values above which the serviceability of any semiconductor device may be impaired.

ELECTRICAL CHARACTERISTICS ($T_a=25^\circ\text{C}$ unless otherwise specified)

Parameter	Symbol	Test conditions	MIN	TYP	MAX	UNIT
Collector-base breakdown voltage	$V_{(BR)CBO}$	$I_C=-0.1\text{mA}, I_E=0$	BC556	-80		V
			BC557	-50		
			BC558	-30		
Collector-emitter breakdown voltage	$V_{(BR)CEO}$	$I_C=-2\text{mA}, I_B=0$	BC556	-65		V
			BC557	-45		
			BC558	-30		
Emitter-base breakdown voltage	$V_{(BR)EBO}$	$I_E=-100\mu\text{A}, I_C=0$	-5			V
Collector cut-off current	I_{CBO}	$V_{CB}=-70\text{V}, I_E=0$	BC556		-0.1	μA
		$V_{CB}=-45\text{V}, I_E=0$	BC557		-0.1	
		$V_{CB}=-25\text{V}, I_E=0$	BC558		-0.1	
Collector cut-off current	I_{CEO}	$V_{CE}=-60\text{V}, I_B=0$	BC556		-0.1	μA
		$V_{CE}=-40\text{V}, I_B=0$	BC557		-0.1	
		$V_{CE}=-25\text{V}, I_B=0$	BC558		-0.1	
Emitter cut-off current	I_{EBO}	$V_{EB}=-5\text{V}, I_C=0$			-0.1	μA
DC current gain	h_{FE}	$V_{CE}=-5\text{V}, I_C=-2\text{mA}$	120		800	
Collector-emitter saturation voltage	$V_{CE(sat)}$	$I_C=-10\text{mA}, I_B=-0.5\text{mA}$			-0.3	V
		$I_C=-100\text{mA}, I_B=-5\text{mA}$			-0.65	V
Base-emitter saturation voltage	$V_{BE(sat)}$	$I_C=-10\text{mA}, I_B=-0.5\text{mA}$			-0.8	V
		$I_C=-100\text{mA}, I_B=-5\text{mA}$			-1	V
Base-emitter voltage	V_{BE}	$V_{CE}=-5\text{V}, I_C=-2\text{mA}$	-0.55		-0.7	V
		$V_{CE}=-5\text{V}, I_C=-10\text{mA}$			-0.82	V
Transition frequency	f_T	$V_{CE}=-5\text{V}, I_C=-10\text{mA}, f=100\text{MHz}$		150		MHz
Collector output capacitance	C_{OB}	$V_{CB}=-10\text{V}, I_E=0, f=1\text{MHz}$			6	pF

CLASSIFICATION OF h_{FE}

Rank	A	B	C
Range	120-220	180-460	420-800

TO-92 Package Outline Dimensions

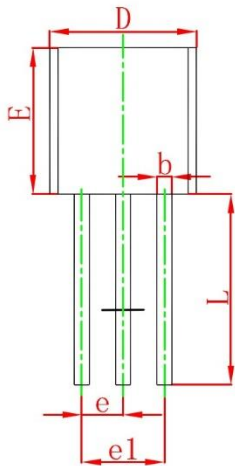
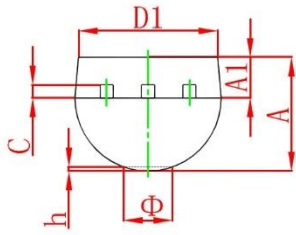

Symbol	Dimensions In Millimeters		Dimensions In Inches	
	Min	Max	Min	Max
A	3.300	3.700	0.130	0.146
A1	1.100	1.400	0.043	0.055
b	0.380	0.550	0.015	0.022
c	0.360	0.510	0.014	0.020
D	4.300	4.700	0.169	0.185
D1	3.430		0.135	
E	4.300	4.700	0.169	0.185
e	1.270 TYP		0.050 TYP	
e1	2.440	2.640	0.096	0.104
L	14.100	14.500	0.555	0.571
Φ		1.600		0.063
h	0.000	0.380	0.000	0.015

TO-92 Suggested Pad Layout

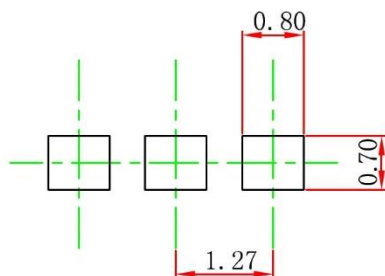

- Note:
1. Controlling dimension: in millimeters.
 2. General tolerance: $\pm 0.05\text{mm}$.
 3. The pad layout is for reference purposes only.

TO-92 Tape and Reel

TO-92 PACKAGE TAPEING DIMENSION

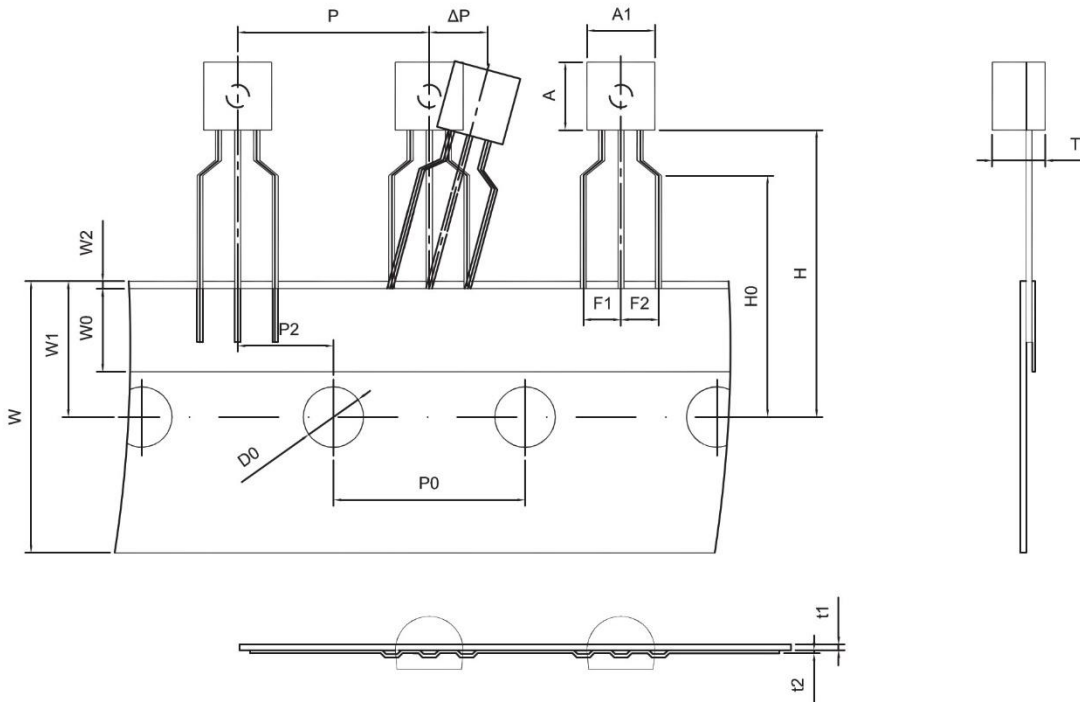

Dimensions are in millimeter

A1	A	T	P	P0	P2	F1	F2	W
4.5	4.5	3.5	12.7	12.7	6.35	2.5	2.5	18.0
W0	W1	W2	H	H0	D0	t1	t2	ΔP
6.0	9.0	1.0 MAX.	19.0	16.0	4.0	0.4	0.2	0

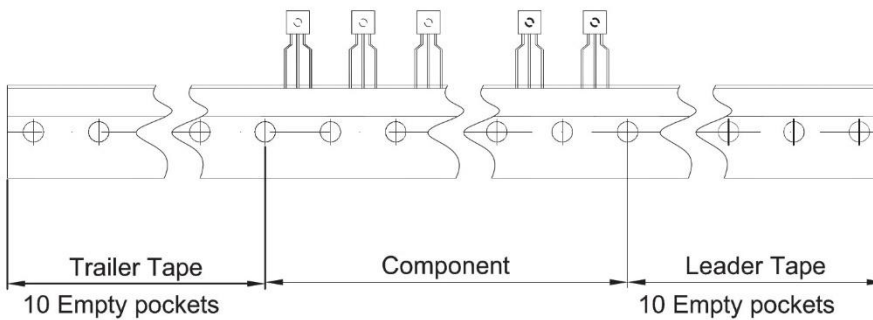

Package	Box	Box Size(mm)	Carton	Carton Size(mm)
TO-92	2000 pcs	333×162×43	20,000 pcs	350×340×250

All products, product specifications and data are subject to change without notice to improve reliability, function or design or otherwise.