

800-7Z7W
CAL24-008
(図面番号 (DRAWING NO.))

版数 VER.	年月日 DATE	CN NO.	変更内容 DESCRIPTION	製図 DR.	担当 CHK.	査閲 APPD.	承認 APPD.
------------	-------------	--------	---------------------	-----------	------------	-------------	-------------

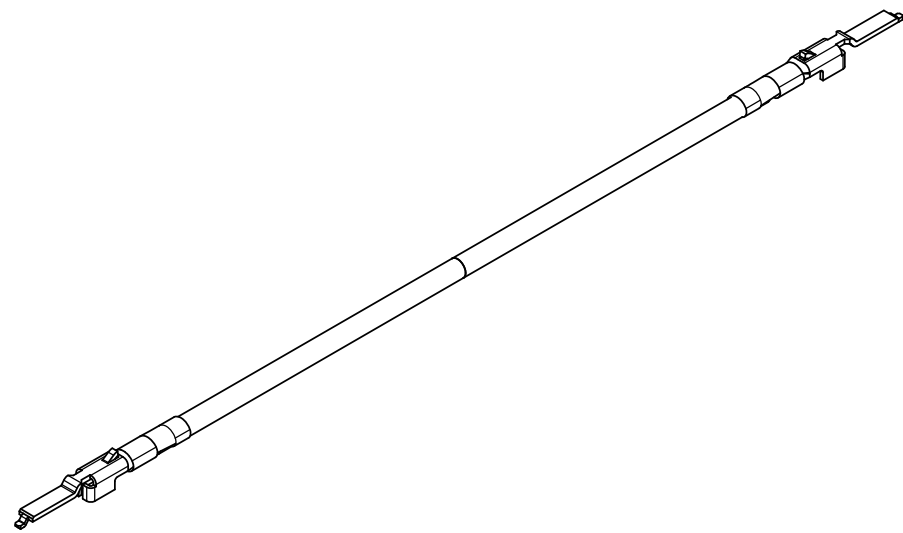
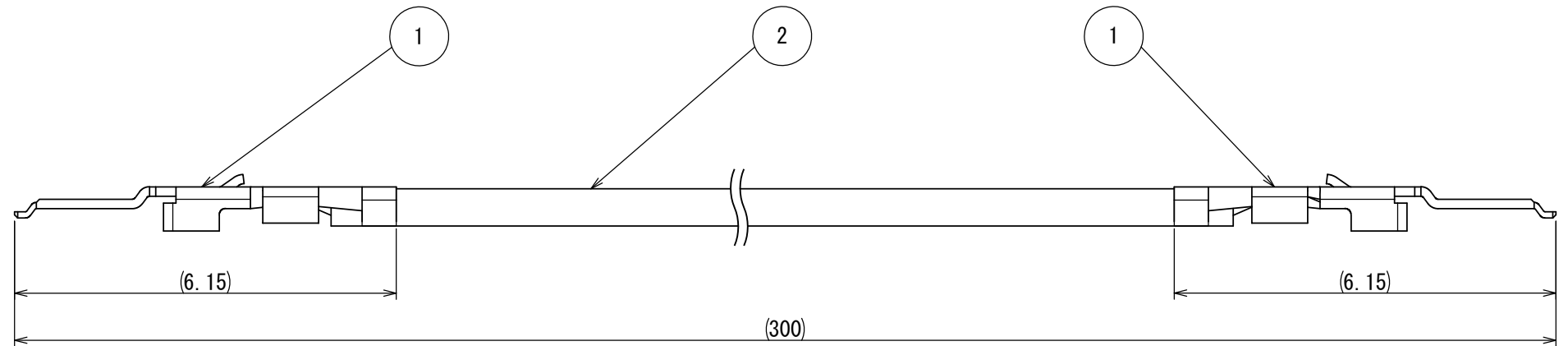

- NOTE 1. INTENDED FOR PROTOTYPE AND TESTING PURPOSES.
- NOTE 2. REFERENCE TERMINAL DRAWING AND SPECIFICATIONS FOR MORE DETAIL.
- NOTE 3. WIRE COLOR IS NOT DETERMINED. SUBJECT TO CHANGE.
- NOTE 4. TERMINAL CRIMPED ON BOTH ENDS.
- NOTE 5. THE CRIMPED WIRE SHOULD ONLY BE INSERTED TO THE SPECIFIED JAE HOUSING AND CAVITY.
- NOTE 6. REFERENCE THE JAE SPECIFICATION AND INSTRUCTION MANUAL FOR PROPER HANDLING AND APPLICABLE HOUSING PART NUMBERS.

2	WIRE	—	UL1571 (AWG #30)	COLOR:— (NOTE3)	—
1	FI-XC3B-1(-15000)	2	COPPER ALLOY	PLATING (MATING AREA): Au (0.1µm MIN) OVER Ni CRIMP AREA: TIN (2µm MIN) OVER Ni	SJ109584
符号 NO.	名称 DESCRIPTION	個数 QTY.	材料 MATERIAL	仕上 FINISH	備考 REMARKS
仕様書 (SPECIFICATION) JACS-1597-*		第1版 (ORIGINAL DATE) 08/FEB/2024		尺度 (SCALE) 1:1	シリーズ (SERIES) MX
一般公差 (GENERAL TOLERANCE)		製図 DR. T. SHIODA		名称 (TITLE) C2777- FI-XC3B-1- AWG30-300	
寸法 (DIMENSION)		担当 CHK. T. SHIODA			
角度 (ANGLES)		査閲 APPD. —			
単位 (UNIT) : mm		承認 APPD. Y. TAKAGI			
±0.8	×° ±	シートの (SHEET NO.) 1 OF 1		質量 (MASS)	日本航空電子工業株式会社 JAE JAPAN AVIATION ELECTRONICS INDUSTRY, LTD.
× ±0.4	×°' ±	シートの (SHEET NO.) 1 OF 1		図面番号 (DRAWING NO.) CAL24-008	
×× ±0.1					版数 (VER.) 1
××× ±					

DCF-G-2121 (20.02)



S/W