

Bridgelux® SMD 5050 Gen3 5W 9V

Product Data Sheet DS298

Introduction

SMD 5050

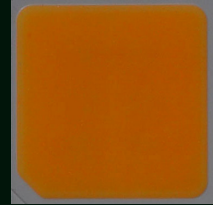

The Bridgelux SMD 5050 Gen3 high power LED is hot-color targeted, which ensures that the LEDs fall within their specified color bin at the typical application conditions of 85°C. With its broad lumen coverage and wide range of CCT and CRI options, the SMD 5050 provides unparalleled design-in flexibility for indoor and outdoor lighting applications. The SMD 5050 is ideal as a drop-in replacement for emitters with an industry standard 5.0mm x 5.0mm footprint.

Features

- Industry-standard 5050 footprint
- 3 color bin options enable tight color control
- Hot-color targeting ensures that color is within the bin at the typical application condition of 85°C
- 3- and 5-step MacAdam ellipse options
- RoHS compliant and lead free
- Multiple CCT and CRI configurations for a wide range of lighting applications

Benefits

- Lower operating and manufacturing cost
- Ease of design and rapid go-to-market
- Uniform consistent white light
- Compliant with environmental standards
- Design flexibility

Contents

Product Feature Map	2
Product Nomenclature	2
Product Test Conditions	2
Product Selection Guide	3
Performance at Commonly Used Drive Currents	5
Electrical Characteristics	9
Absolute Maximum Ratings	10
Product Bin Definitions	11
Performance Curves	14
Typical Radiation Pattern	17
Typical Color Spectrum	18
Mechanical Dimensions	19
Reliability	20
Reflow Characteristics	21
Packaging	22
Design Resources	24
Precautions	24
Disclaimers	24
About Bridgelux	25

Product Feature Map

Bridgelux SMD LED products come in industry standard package sizes and follow ANSI binning standards. These LEDs are optimized for cost and performance, helping to ensure highly competitive system lumen per dollar performance while addressing the stringent efficacy and reliability standards required for modern lighting applications.

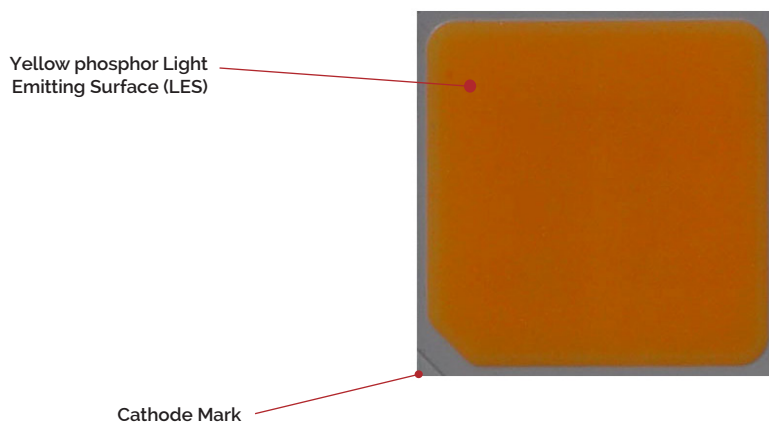

Product Nomenclature

The part number designation for Bridgelux SMD 5050 is explained as follows:

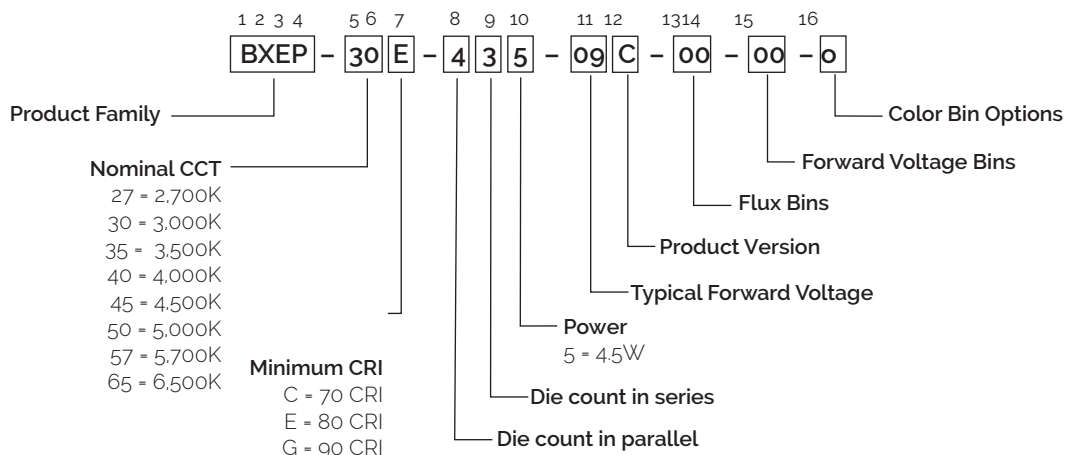

Product Test Conditions

Bridgelux SMD 5050 Gen3 LEDs are tested and binned with a 10ms pulse of 500mA at T_j (junction temperature) = T_{sp} (solder point temperature) = 25°C. Forward voltage and luminous flux are binned at a $T_j = T_{sp} = 25^\circ\text{C}$, while color is hot targeted at a T_{sp} of 85°C.

Product Selection Guide

The following product configurations are available:

Table 1: Selection Guide, Pulsed Measurement Data at 500mA ($T_j = T_{sp} = 25^\circ\text{C}$)

Part Number ^{4,6}	Nominal CCT ² (K)	CRI ^{3,5}	Nominal Drive Current (mA)	Forward Voltage ^{4,5} (V)			Typical Pulsed Flux (lm) ^{4,5}	Typical Power (W)	Typical Efficacy (lm/W)
				Min	Typical	Max			
BXEP-27C-435-09C-00-00-0	2700	70	500	8.5	8.9	10	729	4.5	163
BXEP-27E-435-09C-00-00-0	2700	80	500	8.5	8.9	10	657	4.5	147
BXEP-27G-435-09C-00-00-0	2700	90	500	8.5	8.9	10	557	4.5	125
BXEP-30C-435-09C-00-00-0	3000	70	500	8.5	8.9	10	751	4.5	168
BXEP-30E-435-09C-00-00-0	3000	80	500	8.5	8.9	10	677	4.5	152
BXEP-30G-435-09C-00-00-0	3000	90	500	8.5	8.9	10	574	4.5	128
BXEP-35C-435-09C-00-00-0	3500	70	500	8.5	8.9	10	771	4.5	173
BXEP-35E-435-09C-00-00-0	3500	80	500	8.5	8.9	10	695	4.5	156
BXEP-40C-435-09C-00-00-0	4000	70	500	8.5	8.9	10	791	4.5	177
BXEP-40E-435-09C-00-00-0	4000	80	500	8.5	8.9	10	713	4.5	160
BXEP-40G-435-09C-00-00-0	4000	90	500	8.5	8.9	10	604	4.5	135
BXEP-45C-435-09C-00-00-0	4500	70	500	8.5	8.9	10	791	4.5	177
BXEP-45E-435-09C-00-00-0	4500	80	500	8.5	8.9	10	713	4.5	160
BXEP-50C-435-09C-00-00-0	5000	70	500	8.5	8.9	10	791	4.5	177
BXEP-50E-435-09C-00-00-0	5000	80	500	8.5	8.9	10	713	4.5	160
BXEP-57C-435-09C-00-00-0	5700	70	500	8.5	8.9	10	783	4.5	175
BXEP-57E-435-09C-00-00-0	5700	80	500	8.5	8.9	10	706	4.5	158
BXEP-65C-435-09C-00-00-0	6500	70	500	8.5	8.9	10	775	4.5	174
BXEP-65E-435-09C-00-00-0	6500	80	500	8.5	8.9	10	699	4.5	156

Notes for Table 1:

- The last 7 characters (including hyphens '-') refer to flux bins, forward voltage bins, and color bin options, respectively. "00-00-0" denotes the full distribution of flux, forward voltage, and 7 SDCM color.
Example: BXEP-30E-435-09C-00-00-0 refers to the full distribution of flux, forward voltage, and color within a 3000K 7-step ANSI standard chromaticity region with a minimum of 80CRI, 4x3 die configuration, 4.5w power, 8.9V typical forward voltage.
- Product CCT is hot targeted at $T_{sp} = 85^\circ\text{C}$. Nominal CCT as defined by ANSI C78.377-2011.
- Listed CRIs are minimum values and include test tolerance.
- Products tested under pulsed condition (10ms pulse width) at nominal drive current where $T_j = T_{sp} = 25^\circ\text{C}$.
- Bridgelux maintains a $\pm 7.5\%$ tolerance on luminous flux measurements, $\pm 0.1\text{V}$ tolerance on forward voltage measurements, and ± 2 tolerance on CRI measurements for the SMD 5050 Gen3.
- Refer to Table 6 and Table 7 for Bridgelux SMD 5050 Gen3 Luminous Flux Binning and Forward Voltage Binning information.

Product Selection Guide

The following product configurations are available:

Table 2: Selection Guide, Stabilized DC Performance ($T_{sp} = 85^{\circ}\text{C}$)^{6,7}

Part Number ^{1,5}	Nominal CCT ² (K)	CRI ^{3,4}	Nominal Drive Current (mA)	Forward Voltage ⁴ (V)			Typical DC Flux (lm) ⁶	Typical DC Power (W)	Typical DC Effi- cacy (lm/W)
				Min	Typical	Max			
BXEP-27C-435-09C-00-00-0	2700	70	500	8.3	8.8	9.5	651	4.4	148
BXEP-27E-435-09C-00-00-0	2700	80	500	8.3	8.8	9.5	586	4.4	133
BXEP-27G-435-09C-00-00-0	2700	90	500	8.3	8.8	9.5	497	4.4	113
BXEP-30C-435-09C-00-00-0	3000	70	500	8.3	8.8	9.5	671	4.4	152
BXEP-30E-435-09C-00-00-0	3000	80	500	8.3	8.8	9.5	605	4.4	137
BXEP-30G-435-09C-00-00-0	3000	90	500	8.3	8.8	9.5	512	4.4	116
BXEP-35C-435-09C-00-00-0	3500	70	500	8.3	8.8	9.5	689	4.4	156
BXEP-35E-435-09C-00-00-0	3500	80	500	8.3	8.8	9.5	621	4.4	141
BXEP-40C-435-09C-00-00-0	4000	70	500	8.3	8.8	9.5	706	4.4	160
BXEP-40E-435-09C-00-00-0	4000	80	500	8.3	8.8	9.5	636	4.4	145
BXEP-40G-435-09C-00-00-0	4000	90	500	8.3	8.8	9.5	539	4.4	123
BXEP-45C-435-09C-00-00-0	4500	70	500	8.3	8.8	9.5	706	4.4	160
BXEP-45E-435-09C-00-00-0	4500	80	500	8.3	8.8	9.5	636	4.4	145
BXEP-50C-435-09C-00-00-0	5000	70	500	8.3	8.8	9.5	706	4.4	160
BXEP-50E-435-09C-00-00-0	5000	80	500	8.3	8.8	9.5	636	4.4	145
BXEP-57C-435-09C-00-00-0	5700	70	500	8.3	8.8	9.5	699	4.4	159
BXEP-57E-435-09C-00-00-0	5700	80	500	8.3	8.8	9.5	630	4.4	143
BXEP-65C-435-09C-00-00-0	6500	70	500	8.3	8.8	9.5	693	4.4	157
BXEP-65E-435-09C-00-00-0	6500	80	500	8.3	8.8	9.5	624	4.4	142

Notes for Table 2:

- The last 7 characters (including hyphens '-') refer to flux bins, forward voltage bins, and color bin options, respectively. "00-00-0" denotes the full distribution of flux, forward voltage, and 7 SDCM color.
Example: BXEP-30E-435-09C-00-00-0 refers to the full distribution of flux, forward voltage, and color within a 3000K 7-step ANSI standard chromaticity region with a minimum of 80CRI, 4x3 die configuration, 4.5w power, 8.9V typical forward voltage.
- Product CCT is hot targeted at $T_{sp} = 85^{\circ}\text{C}$. Nominal CCT as defined by ANSI C78.377-2011.
- Listed CRIs are minimum values and include test tolerance.
- Bridgelux maintains a $\pm 7.5\%$ tolerance on luminous flux measurements, $\pm 0.1\text{V}$ tolerance on forward voltage measurements, and ± 2 tolerance on CRI measurements for the SMD 5050 Gen3.
- Refer to Table 6 and Table 7 for Bridgelux SMD 5050 Gen3 Luminous Flux Binning and Forward Voltage Binning information.
- Typical stabilized DC performance values are provided as reference only and are not a guarantee of performance.
- Typical performance is estimated based on operation under DC (direct current) with LED emitter mounted onto a heat sink with thermal interface material and the solder point temperature maintained at 85°C . Based on Bridgelux test setup, values may vary depending on the thermal design of the luminaire and/or the exposed environment to which the product is subjected.

Performance at Commonly Used Drive Currents

SMD 5050 LEDs are tested to the specifications shown using the nominal drive currents in Table 1. SMD 5050 may also be driven at other drive currents dependent on specific application design requirements. The performance at any drive current can be derived from the current vs. voltage characteristics shown in Figure 2 and the relative luminous flux vs. current characteristics shown in Figure 3. The performance at commonly used drive currents is summarized in Table 3.

Table 3: Performance at Commonly Used Drive Currents

Part Number	CRI	Drive Current ¹ (mA)	Typical V_f $T_{sp} = 25^\circ\text{C}$ (V)	Typical Power $T_{sp} = 25^\circ\text{C}$ (W)	Typical Pulsed Flux ² $T_{sp} = 25^\circ\text{C}$ (lm)	Typical DC Flux ³ $T_{sp} = 85^\circ\text{C}$ (lm)	Typical Efficacy $T_{sp} = 25^\circ\text{C}$ (lm/W)
BXEP-27C-435-09C-00-00-0	70	125	8.1	1.0	194	176	192
		250	8.4	2.1	381	345	181
		375	8.7	3.3	559	502	172
		500	8.9	4.5	729	651	163
		625	9.2	5.7	889	788	155
		750	9.4	7.1	1044	918	148
		960	9.8	9.4	1273	1120	135
BXEP-27E-435-09C-00-00-0	80	125	8.1	1.0	175	159	173
		250	8.4	2.1	344	311	163
		375	8.7	3.3	504	453	155
		500	8.9	4.5	657	586	147
		625	9.2	5.7	801	710	140
		750	9.4	7.1	941	827	133
		960	9.8	9.4	1147	1009	122
BXEP-27G-435-09C-00-00-0	90	125	8.1	1.0	148	135	147
		250	8.4	2.1	291	263	138
		375	8.7	3.3	427	383	131
		500	8.9	4.5	557	497	125
		625	9.2	5.7	679	602	118
		750	9.7	7.2	797	701	110
		960	10.1	9.7	972	855	101
BXEP-30C-435-09C-00-00-0	70	125	8.1	1.0	200	182	198
		250	8.4	2.1	393	355	187
		375	8.7	3.3	576	518	177
		500	8.9	4.5	751	671	168
		625	9.2	5.7	917	813	160
		750	9.4	7.1	1077	947	153
		960	9.8	9.4	1312	1155	140
BXEP-30E-435-09C-00-00-0	80	125	8.1	1.0	181	164	178
		250	8.4	2.1	354	320	168
		375	8.7	3.3	519	467	160
		500	8.9	4.5	677	605	152
		625	9.2	5.7	826	732	144
		750	9.4	7.1	970	853	137
		960	9.8	9.4	1182	1041	126

Notes for Table 3:

1. Alternate drive currents in Table 3 are provided for reference only and are not a guarantee of performance.
2. Bridgelux maintains a $\pm 7.5\%$ tolerance on flux measurements.
3. Typical stabilized DC performance values are provided as reference only and are not a guarantee of performance.

Performance at Commonly Used Drive Currents

Table 3: Performance at Commonly Used Drive Currents(Continued)

Part Number	CRI	Drive Current ¹ (mA)	Typical V_f $T_{sp} = 25^\circ\text{C}$ (V)	Typical Power $T_{sp} = 25^\circ\text{C}$ (W)	Typical Pulsed Flux ² $T_{sp} = 25^\circ\text{C}$ (lm)	Typical DC Flux ³ $T_{sp} = 85^\circ\text{C}$ (lm)	Typical Efficacy $T_{sp} = 25^\circ\text{C}$ (lm/W)
BXEP-30G-435-09C-00-00-0	90	125	8.1	1.0	153	139	151
		250	8.4	2.1	300	271	143
		375	8.7	3.3	440	395	135
		500	8.9	4.5	574	512	128
		625	9.2	5.7	700	620	122
		750	9.4	7.1	822	723	117
		960	9.8	9.4	1002	882	107
BXEP-35C-435-09C-00-00-0	70	125	8.1	1.0	206	187	203
		250	8.4	2.1	404	365	192
		375	8.7	3.3	592	531	182
		500	8.9	4.5	771	689	173
		625	9.2	5.7	941	834	164
		750	9.4	7.1	1105	972	157
		960	9.8	9.4	1347	1185	143
BXEP-35E-435-09C-00-00-0	80	125	8.1	1.0	185	168	183
		250	8.4	2.1	364	329	173
		375	8.7	3.3	533	479	164
		500	8.9	4.5	695	621	156
		625	9.2	5.7	848	751	148
		750	9.4	7.1	995	875	141
		960	9.8	9.4	1214	1068	129
BXEP-40C-435-09C-00-00-0	70	125	8.1	1.0	211	191	208
		250	8.4	2.1	414	374	197
		375	8.7	3.3	607	545	186
		500	8.9	4.5	791	706	177
		625	9.2	5.7	965	855	168
		750	9.7	7.2	1133	997	156
		960	10.1	9.7	1382	1216	143
BXEP-40E-435-09C-00-00-0	80	125	8.1	1.0	190	172	188
		250	8.4	2.1	373	337	177
		375	8.7	3.3	547	491	168
		500	8.9	4.5	713	636	160
		625	9.2	5.7	869	771	152
		750	9.4	7.1	1021	898	145
		960	9.8	9.4	1245	1095	132

Notes for Table 3:

1. Alternate drive currents in Table 3 are provided for reference only and are not a guarantee of performance.
2. Bridgelux maintains a $\pm 7.5\%$ tolerance on flux measurements.
3. Typical stabilized DC performance values are provided as reference only and are not a guarantee of performance.

Performance at Commonly Used Drive Currents

Table 3: Performance at Commonly Used Drive Currents(Continued)

Part Number	CRI	Drive Current ¹ (mA)	Typical V_f $T_{sp} = 25^\circ\text{C}$ (V)	Typical Power $T_{sp} = 25^\circ\text{C}$ (W)	Typical Pulsed Flux ² $T_{sp} = 25^\circ\text{C}$ (lm)	Typical DC Flux ³ $T_{sp} = 85^\circ\text{C}$ (lm)	Typical Efficacy $T_{sp} = 25^\circ\text{C}$ (lm/W)
BXEP-40G-435-09C-00-00-0	90	125	8.1	1.0	161	146	159
		250	8.4	2.1	316	286	150
		375	8.7	3.3	463	416	142
		500	8.9	4.5	604	539	135
		625	9.2	5.7	737	653	129
		750	9.4	7.1	865	761	123
		960	9.8	9.4	1055	928	112
BXEP-45C-435-09C-00-00-0	70	125	8.1	1.0	211	191	208
		250	8.4	2.1	414	374	197
		375	8.7	3.3	607	545	186
		500	8.9	4.5	791	706	177
		625	9.2	5.7	965	855	168
		750	9.4	7.1	1133	997	161
		960	9.8	9.4	1382	1216	147
BXEP-45E-435-09C-00-00-0	80	125	8.1	1.0	190	172	188
		250	8.4	2.1	373	337	177
		375	8.7	3.3	547	491	168
		500	8.9	4.5	713	636	160
		625	9.2	5.7	869	771	152
		750	9.4	7.1	1021	898	145
		960	9.8	9.4	1245	1095	132
BXEP-50C-435-09C-00-00-0	70	125	8.1	1.0	211	191	208
		250	8.4	2.1	414	374	197
		375	8.7	3.3	607	545	186
		500	8.9	4.5	791	706	177
		625	9.2	5.7	965	855	168
		750	9.4	7.1	1133	997	161
		960	9.8	9.4	1382	1216	147
BXEP-50E-435-09C-00-00-0	80	125	8.1	1.0	190	172	188
		250	8.4	2.1	373	337	177
		375	8.7	3.3	547	491	168
		500	8.9	4.5	713	636	160
		625	9.2	5.7	869	771	152
		750	9.4	7.1	1021	898	145
		960	9.8	9.4	1245	1095	132

Notes for Table 3:

1. Alternate drive currents in Table 3 are provided for reference only and are not a guarantee of performance.
2. Bridgelux maintains a $\pm 7.5\%$ tolerance on flux measurements.
3. Typical stabilized DC performance values are provided as reference only and are not a guarantee of performance.

Performance at Commonly Used Drive Currents

Table 3: Performance at Commonly Used Drive Currents(Continued)

Part Number	CRI	Drive Current ¹ (mA)	Typical V_f $T_{sp} = 25^\circ\text{C}$ (V)	Typical Power $T_{sp} = 25^\circ\text{C}$ (W)	Typical Pulsed Flux ² $T_{sp} = 25^\circ\text{C}$ (lm)	Typical DC Flux ³ $T_{sp} = 85^\circ\text{C}$ (lm)	Typical Efficacy $T_{sp} = 25^\circ\text{C}$ (lm/W)
BXEP-57C-435-09C-00-00-0	70	125	8.1	1.0	209	190	206
		250	8.4	2.1	410	370	195
		375	8.7	3.3	601	540	185
		500	8.9	4.5	783	699	175
		625	9.2	5.7	956	847	167
		750	9.4	7.1	1122	987	159
		960	9.8	9.4	1368	1204	146
BXEP-57E-435-09C-00-00-0	80	125	8.1	1.0	188	171	186
		250	8.4	2.1	369	334	175
		375	8.7	3.3	541	486	166
		500	8.9	4.5	706	630	158
		625	9.2	5.7	861	763	150
		750	9.4	7.1	1011	889	143
		960	9.8	9.4	1232	1084	131
BXEP-65C-435-09C-00-00-0	70	125	8.1	1.0	207	188	204
		250	8.4	2.1	406	367	193
		375	8.7	3.3	595	534	183
		500	8.9	4.5	775	693	174
		625	9.2	5.7	946	839	165
		750	9.4	7.1	1111	977	157
		960	9.8	9.4	1354	1192	144
BXEP-65E-435-09C-00-00-0	80	125	8.1	1.0	186	169	184
		250	8.4	2.1	366	330	174
		375	8.7	3.3	536	481	165
		500	8.9	4.5	699	624	156
		625	9.2	5.7	852	755	149
		750	9.4	7.1	1001	880	142
		960	9.8	9.4	1220	1074	130

Notes for Table 3:

1. Alternate drive currents in Table 3 are provided for reference only and are not a guarantee of performance.
2. Bridgelux maintains a $\pm 7.5\%$ tolerance on flux measurements.
3. Typical stabilized DC performance values are provided as reference only and are not a guarantee of performance.

Electrical Characteristics

Table 4: Electrical Characteristics

Part Number ¹	Drive Current (mA)	Forward Voltage (V) ^{2,3}			Typical Temperature Coefficient of Forward Voltage $\Delta V_f / \Delta T$ (mV/°C)	Typical Thermal Resistance Junction to Solder Point ⁴ R_{j-sp} (°C/W)
		Minimum	Typical	Maximum		
BXEP-XXX-435-09C-00-00-0	500	8.5	8.9	10	-1.4	2.2

Notes for Table 4:

- The last 7 characters (including hyphens '-') refer to flux bins, forward voltage bins, and color bin options, respectively. "00-00-0" denotes the full distribution of flux, forward voltage, and 7 SDCM color.
Example: BXEP-30E-435-09C-00-00-0 refers to the full distribution of flux, forward voltage, and color within a 3000K 7-step ANSI standard chromaticity region with a minimum of 80CRI, 4x3 die configuration, 4.5w power, 8.9V typical forward voltage.
- Bridgelux maintains a tolerance of $\pm 0.1V$ on forward voltage measurements. Voltage minimum and maximum values at the nominal drive current are guaranteed by 100% test.
- Products tested under pulsed condition (10ms pulse width) at nominal drive current where $T_{sp} = 25^{\circ}C$.
- Thermal resistance value based on 4000K 80CRI product.
- Thermal resistance value was calculated using total electrical input power; optical power was not subtracted from input power.

Absolute Maximum Ratings

Table 5: Maximum Ratings

Parameter	Maximum Rating
LED Junction Temperature (T_j)	125°C
Storage Temperature	-40°C to +105°C
Operating Solder Point Temperature (T_{sp})	-40°C to +105°C
Soldering Temperature	260°C or lower for a maximum of 10 seconds
Maximum Drive Current ¹	960 mA
Maximum Peak Pulsed Forward Current ²	1200 mA
Maximum Reverse Voltage ³	-
Moisture Sensitivity Rating	MSL 3
Electrostatic Discharge	2kV HBM. JEDEC-JS-001-HBM and JEDEC-JS-001-2012

Notes for Table 5:

1. Maximum drive current may be limited by the solder point temperature. Please see Figure 7 for further details.
2. Bridgelux recommends a maximum duty cycle of 10% and pulse width of 10 ms when operating LED SMD at maximum peak pulsed current specified. Maximum peak pulsed current indicate values where LED SMD can be driven without catastrophic failures.
3. Light emitting diodes are not designed to be driven in reverse voltage and will not produce light under this condition, no rating is provided.
4. The maximum driver current tested under LM80 is 128% of the nominal drive current (640mA).

Product Bin Definitions

Table 6 lists the standard photometric luminous flux bins for Bridgelux SMD 5050 LEDs. Although several bins are listed, product availability in a particular bin varies by production run and by product performance. Not all bins are available in all CCTs.

Table 6: Luminous Flux Bin Definitions at 500mA, $T_{sp}=25^{\circ}\text{C}$

Bin Code	Minimum	Maximum	Unit	Condition
A7	470	505	lm	$I_F=500\text{mA}$
A8	505	545		
A9	545	590		
B1	590	635		
B2	635	685		
B3	685	740		
B4	740	800		
B5	800	865		

Note for Table 6:

1. Bridgelux maintains a tolerance of $\pm 7.5\%$ on luminous flux measurements.

Table 7: Forward Voltage Bin Definition at 500mA, $T_{sp}=25^{\circ}\text{C}$

Bin Code	Minimum	Maximum	Unit	Condition
CD	8.5	9.0	V	$I_F=500\text{mA}$
CE	9.0	9.5		
CF	9.5	10.0		

Note for Table 7:

1. Bridgelux maintains a tolerance of $\pm 0.1\text{V}$ on forward voltage measurements.

Product Bin Definitions

Table 8: 3- and 5-step MacAdam Ellipse Color Bin Definitions

CCT	Color Space	Center Point		Major Axis	Minor Axis	Ellipse Rotation Angle	Color Bin
		X	Y				
2700K	3 SDCM	0.4578	0.4101	0.00810	0.00420	53.70	3
	5 SDCM	0.4578	0.4101	0.01350	0.00700	53.70	5
3000K	3 SDCM	0.4338	0.4030	0.00834	0.00408	53.22	3
	5 SDCM	0.4338	0.4030	0.01390	0.00680	53.22	5
3500K	3 SDCM	0.4103	0.3961	0.00927	0.00414	54.00	3
	5 SDCM	0.4103	0.3961	0.01545	0.00690	54.00	5
4000K	3 SDCM	0.3818	0.3797	0.00939	0.00402	53.72	3
	5 SDCM	0.3818	0.3797	0.01565	0.00670	53.72	5
4500K	3 SDCM	0.3611	0.3658	0.00756	0.00338	57.58	3
	5 SDCM	0.3611	0.3658	0.01260	0.00563	57.58	5
5000K	3 SDCM	0.3447	0.3553	0.00822	0.00354	59.62	3
	5 SDCM	0.3447	0.3553	0.01370	0.00590	59.62	5
5700K	3 SDCM	0.3287	0.3417	0.00746	0.00320	59.09	3
	5 SDCM	0.3287	0.3417	0.01243	0.00533	59.09	5
6500K	3 SDCM	0.3123	0.3282	0.00669	0.00285	58.57	3
	5 SDCM	0.3123	0.3282	0.01115	0.00475	58.57	5

Notes for Table 8:

1. Color binning at $T_{sp}=85^{\circ}\text{C}$
2. Bridgelux maintains a tolerance of ± 0.007 on x and y color coordinates in the CIE 1931 color space.

Product Bin Definitions

Figure 1: C.I.E. 1931 Chromaticity Diagram (3 Color Bin Structure, Hot-color Targeted at $T_{sp} = 85^{\circ}\text{C}$)

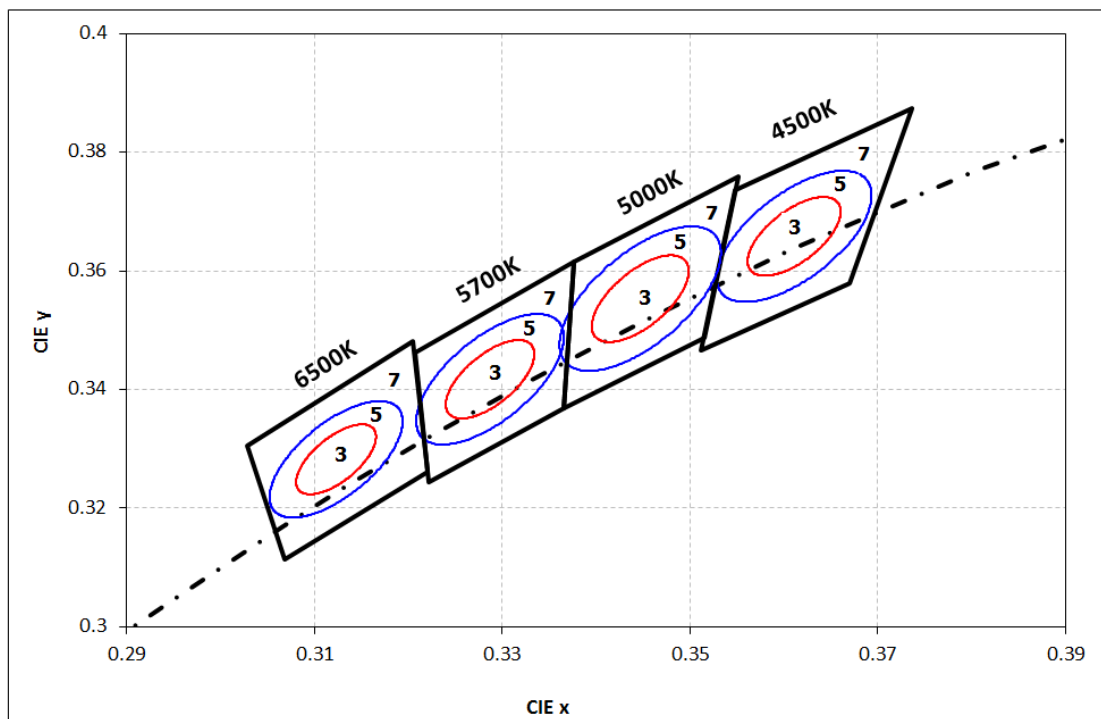
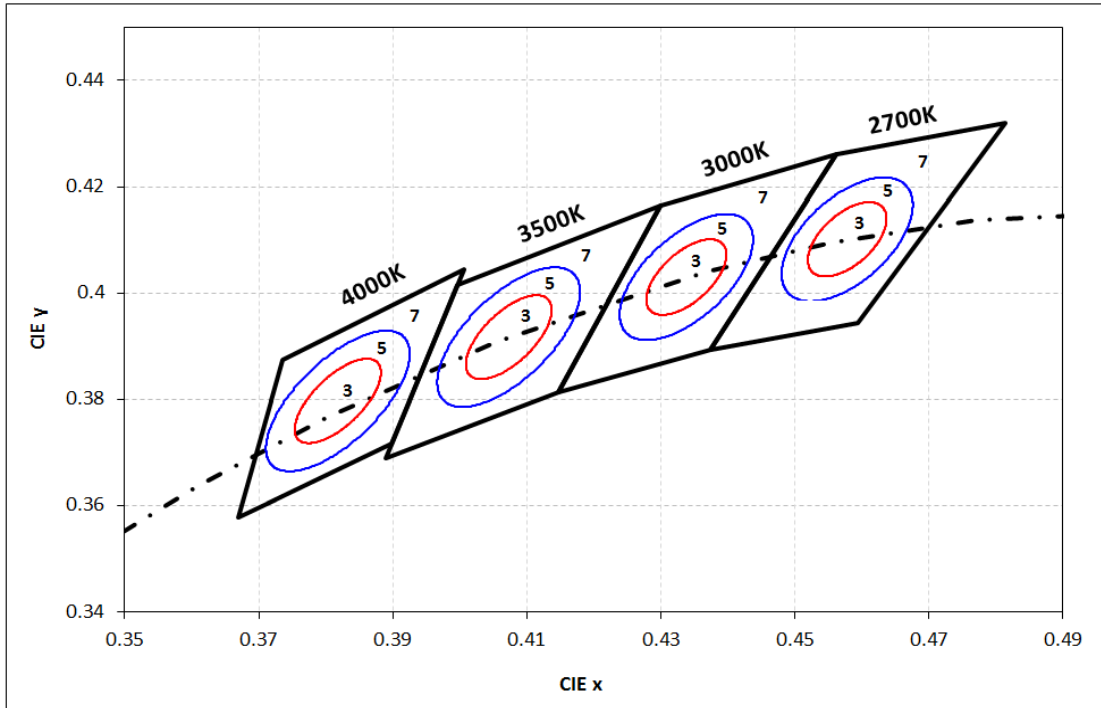

Performance Curves

Figure 2: Drive Current vs. Voltage ($T_{sp}=25^{\circ}\text{C}$)



Figure 3: Typical Relative Luminous Flux vs. Drive Current ($T_{sp}=25^{\circ}\text{C}$)

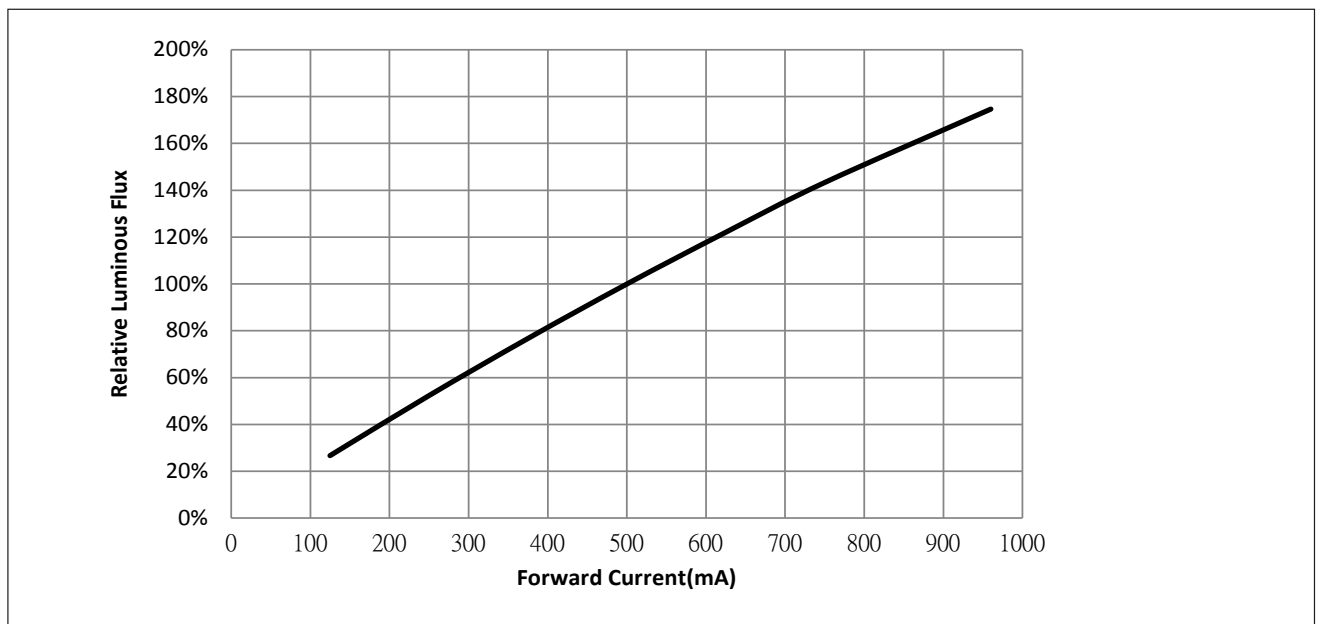

Note for Figure 3:

1. Bridgelux does not recommend driving high power LEDs at low currents. Doing so may produce unpredictable results. Pulse width modulation (PWM) is recommended for dimming effects.

Performance Curves

Figure 4: Typical Relative DC Flux vs. Solder Point Temperature

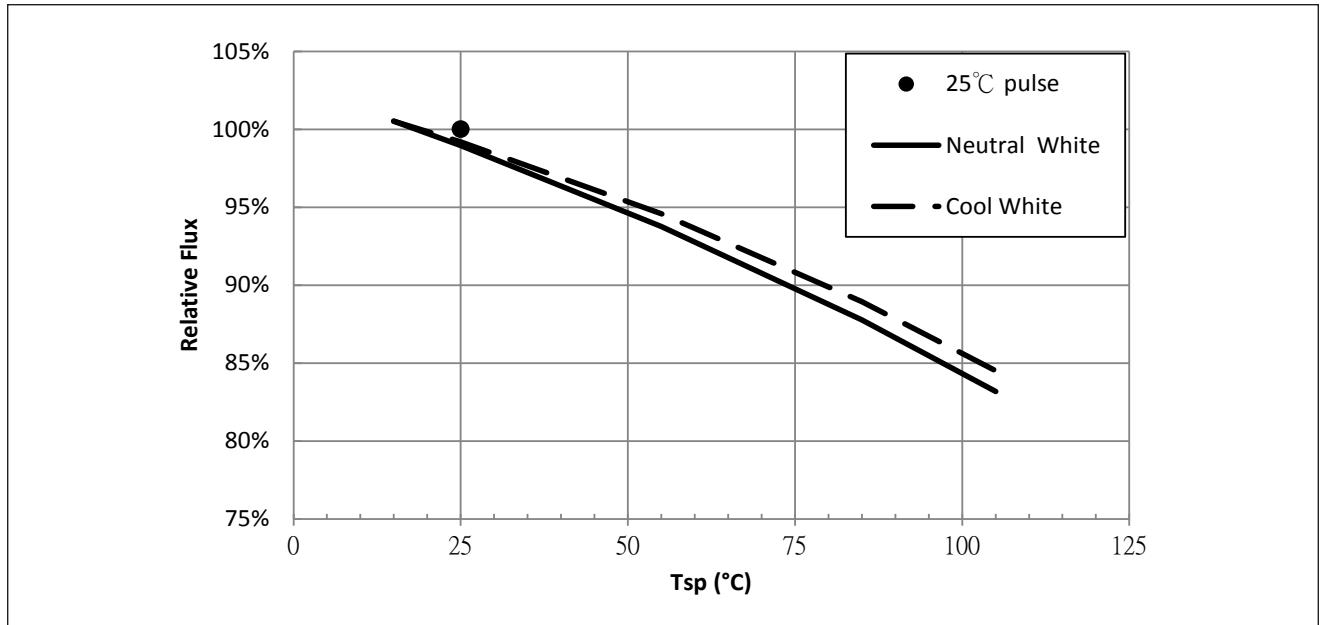
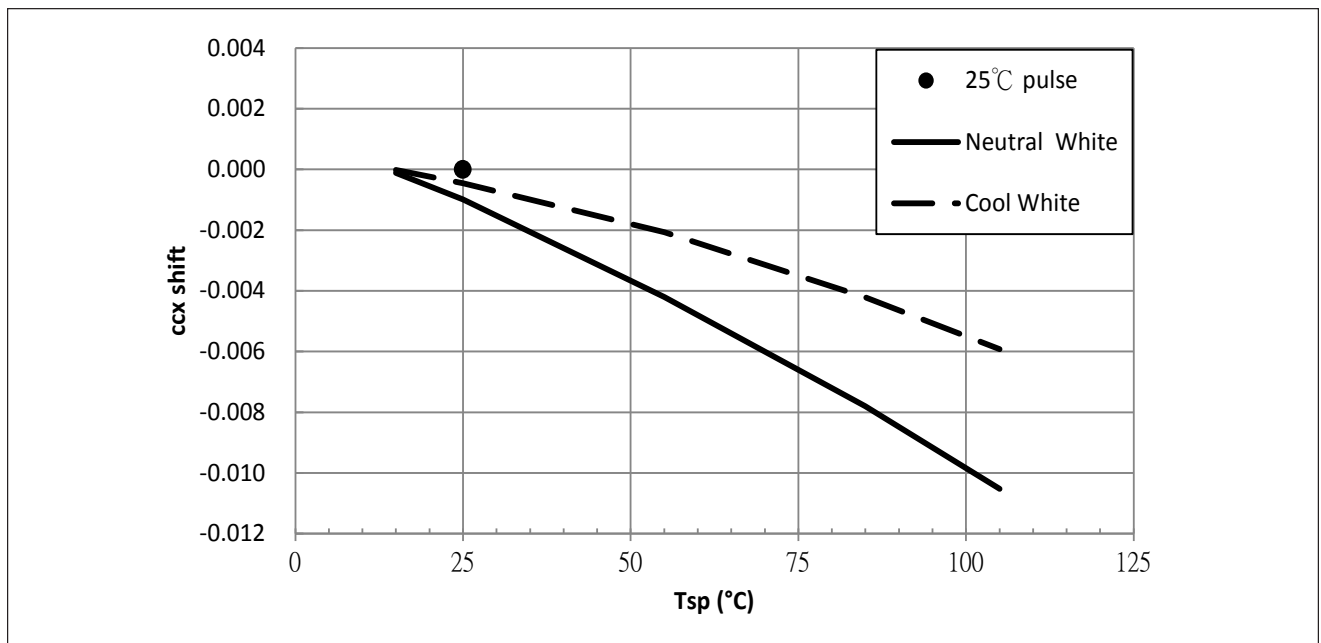

Figure 5: Typical DC ccx Shift vs. Solder Point Temperature



Notes for Figures 4 & 5:

1. Characteristics shown for neutral white based on 4000K and 80 CRI.
2. Characteristics shown for cool white based on 5700K and 70 CRI.
3. For other color SKUs, the shift in color will vary. Please contact your Bridgelux Sales Representative for more information.

Performance Curves

Figure 6: Typical DC ccy Shift vs. Solder Point Temperature

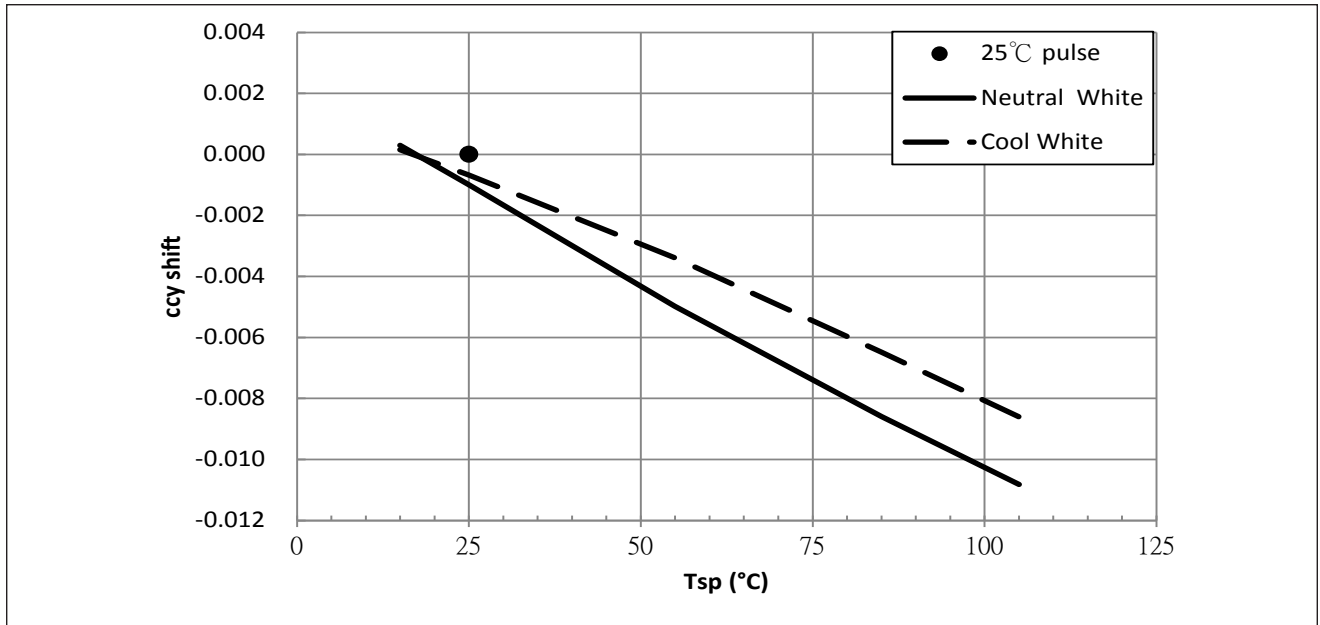

Notes for Figure 6:

1. Characteristics shown for neutral white based on 4000K and 80 CRI.
2. Characteristics shown for cool white based on 5700K and 70 CRI.
3. For other color SKUs, the shift in color will vary. Please contact your Bridgelux Sales Representative for more information.

Figure 7: Drive Current Derating Curve

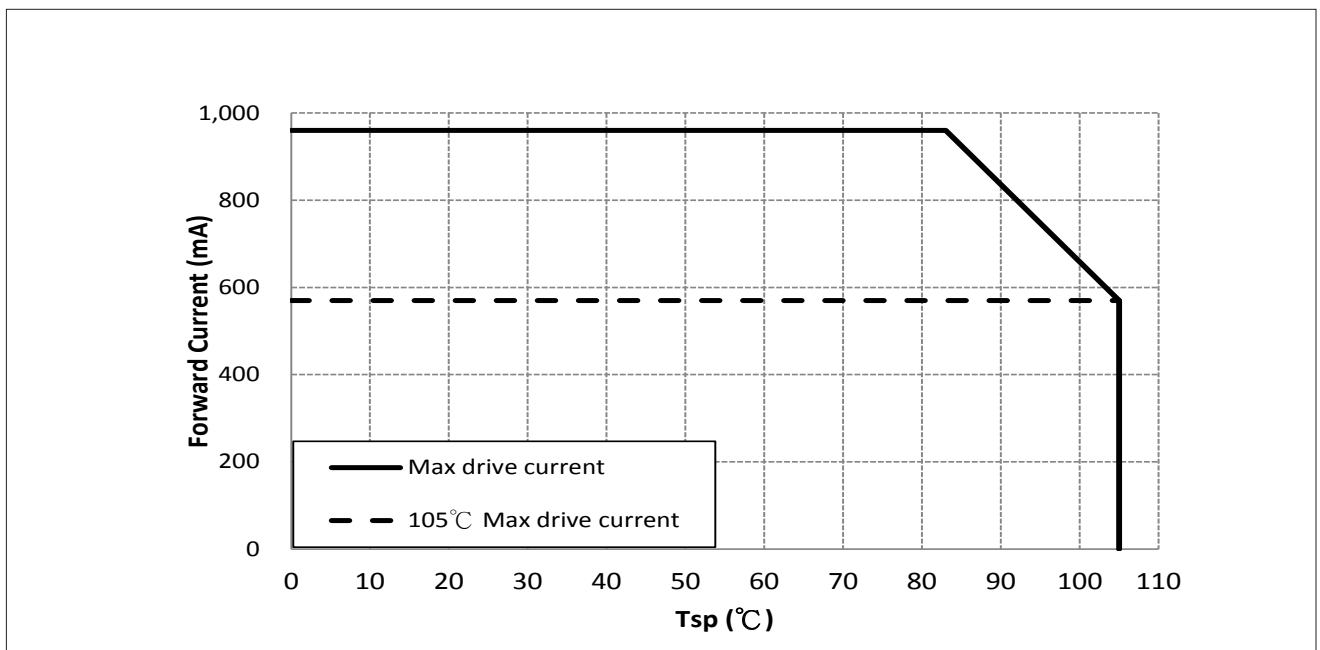

Typical Radiation Pattern

Figure 8: Typical Spatial Radiation Pattern at 500mA, $T_{sp} = 25^{\circ}\text{C}$

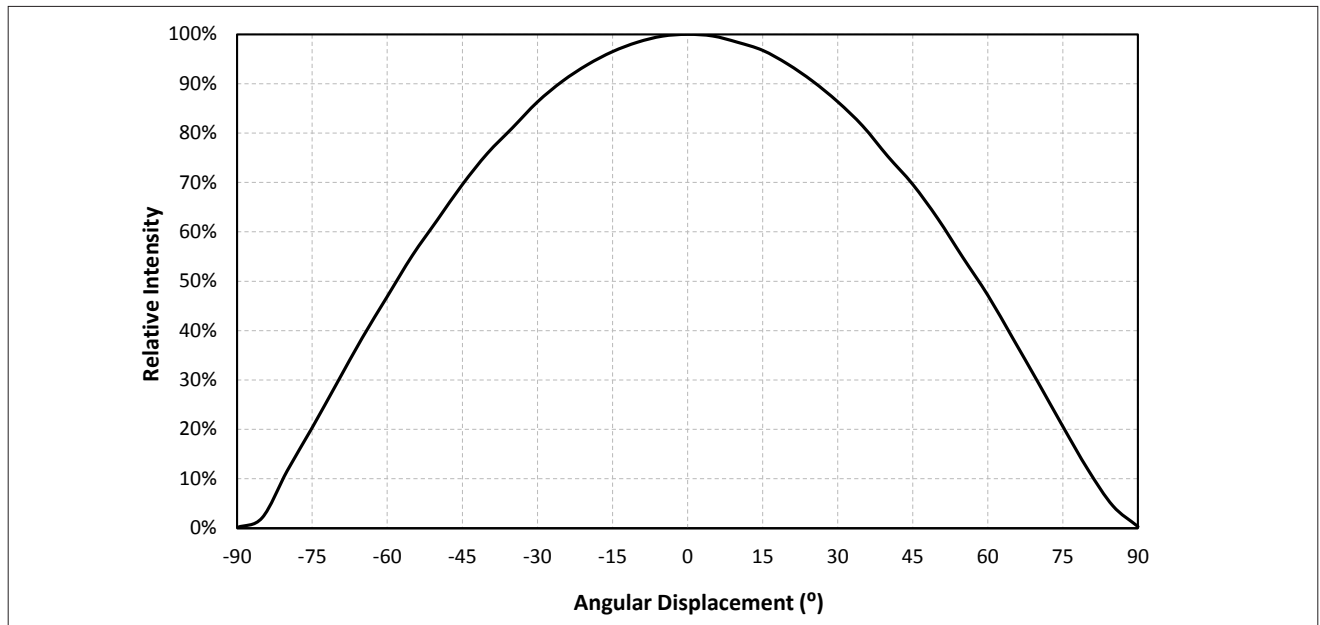

Notes for Figure 8:

1. Typical viewing angle is 116° .
2. The viewing angle is defined as the off axis angle from the centerline where luminous intensity (lv) is $\frac{1}{2}$ of the peak value.

Figure 9: Typical Polar Radiation Pattern at 500mA, $T_{sp} = 25^{\circ}\text{C}$

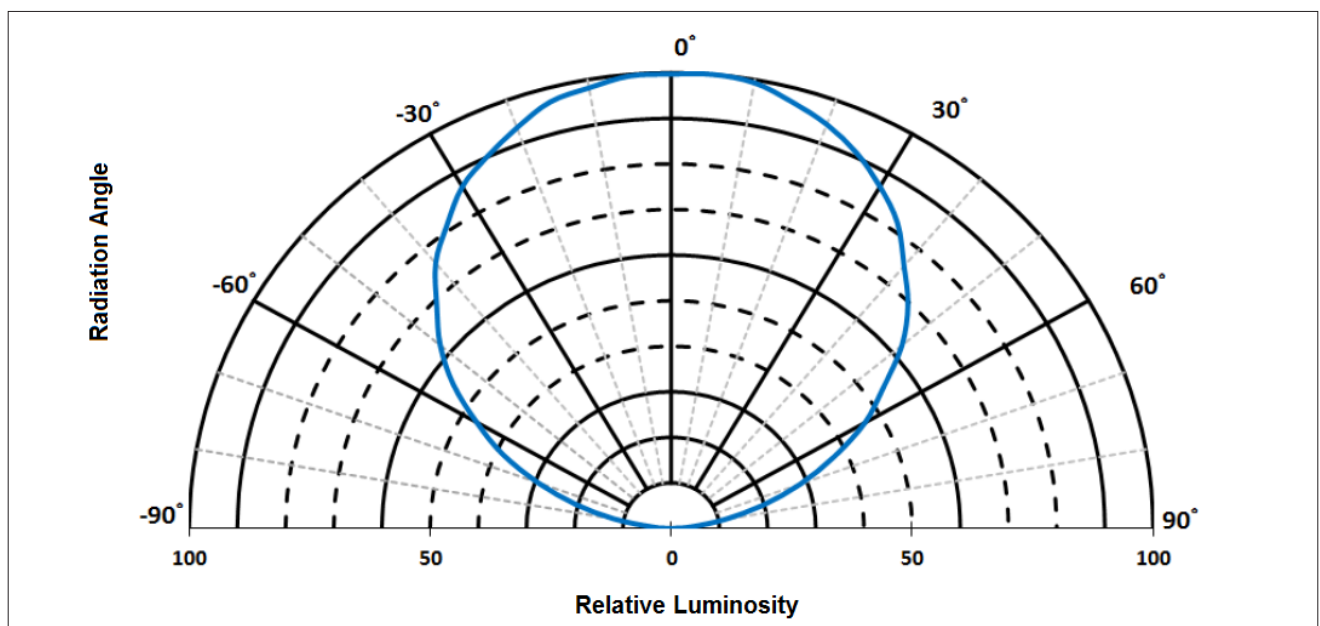

Typical Color Spectrum

Figure 10: Typical Color Spectrum

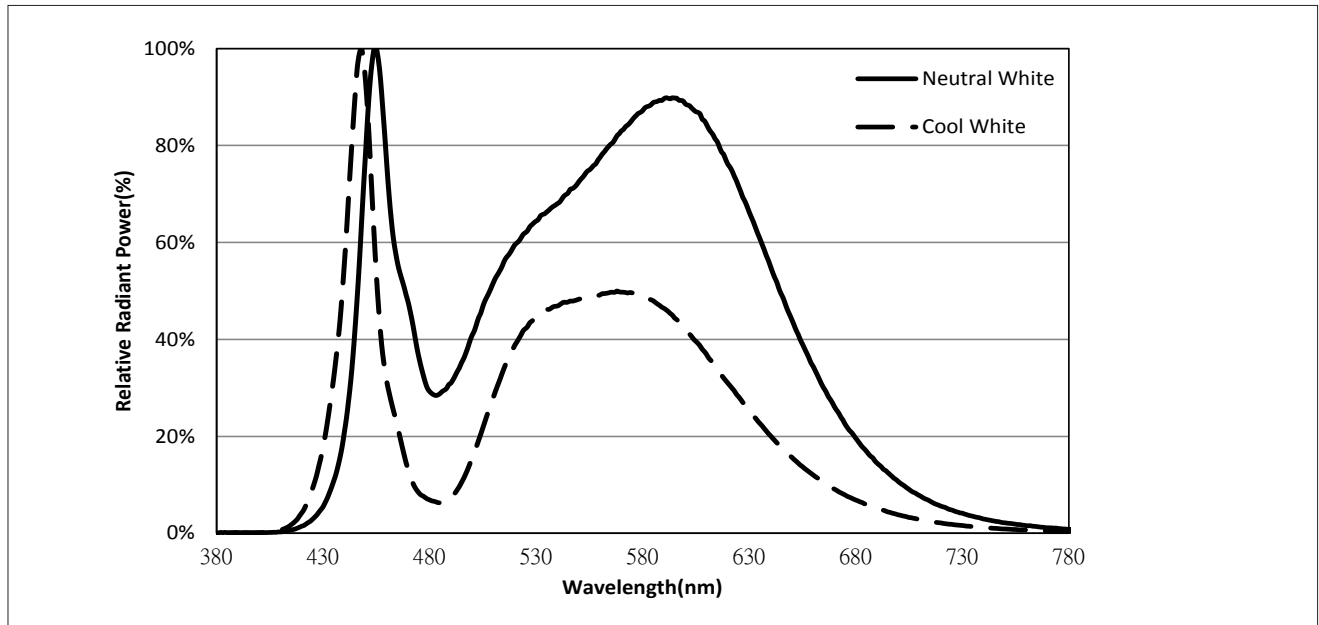

Notes for Figure 10:

1. Color spectra measured at nominal current for $T_{sp} = 25^{\circ}\text{C}$
2. Color spectra shown for neutral white is 4000K and 80 CRI.
3. Color spectra shown for cool white is 5700K and 70 CRI.

Mechanical Dimensions

Figure 11: Drawing for SMD 5050

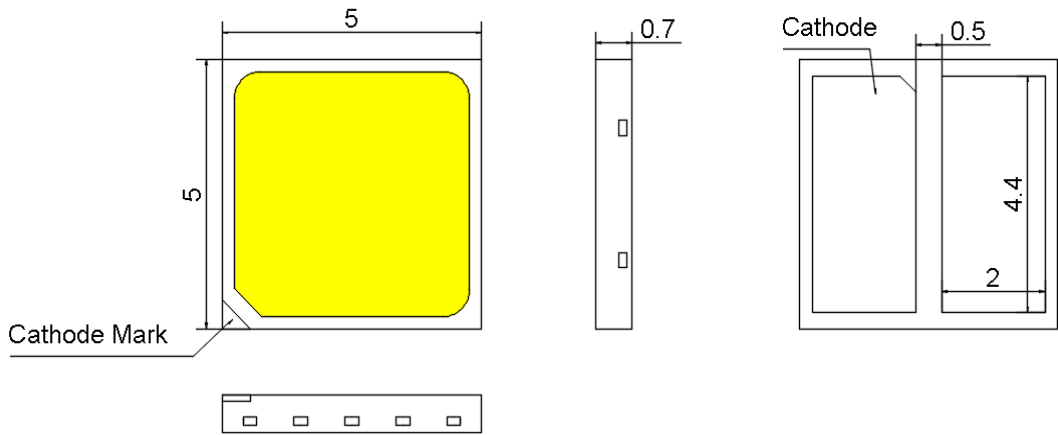

- Notes for Figure 11:
1. Drawings are not to scale.
 2. Drawing dimensions are in millimeters.
 3. Unless otherwise specified, tolerances are $\pm 0.10\text{mm}$.

Recommended PCB Soldering Pad Pattern

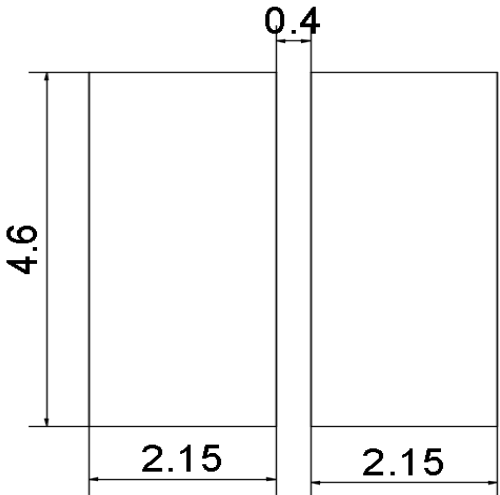

Reliability

Table 9: Reliability Test Items and Conditions

No .	Items	Reference Standard	Test Conditions	Drive Current	Test Duration	Units Failed/Tested
1	Moisture/Reflow Sensitivity	J-STD-020E	$T_{sld} = 260^{\circ}\text{C}$, 10sec, Precondition: 60°C , 60%RH, 168hr	-	3 reflows	0/22
2	Low Temperature Storage	JESD22-A119	$T_a = -40^{\circ}\text{C}$	-	1000 hours	0/22
3	High Temperature Storage	JESD22-A103D	$T_a = 105^{\circ}\text{C}$	-	1000 hours	0/22
4	Low Temperature Operating Life	JESD22-A108D	$T_a = -40^{\circ}\text{C}$	500mA	1000 hours	0/22
5	Temperature Humidity Operating Life	JESD22-A101C	$T_{sp} = 85^{\circ}\text{C}$, RH=85%	500mA	1000 hours	0/22
6	High Temperature Operating Life	JESD22-A108D	$T_{sp} = 105^{\circ}\text{C}$	640mA	1000 hours	0/22
7	Power switching	IEC62717:2014	$T_{sp} = 105^{\circ}\text{C}$ 30 sec on, 30 sec off	640mA	30000 cycles	0/22
8	Thermal Shock	JESD22-A106B	$T_a = -40^{\circ}\text{C} \sim 100^{\circ}\text{C}$; Dwell : 15min; Transfer: 10sec	-	200 cycles	0/22
9	Temperature Cycle	JESD22-A104E	$T_a = -40^{\circ}\text{C} \sim 100^{\circ}\text{C}$; Dwell at extreme temperature: 15min; Ramp rate < $105^{\circ}\text{C}/\text{min}$	-	200 cycles	0/22
10	Electrostatic Discharge	JS-001-2012	HBM, 2kV, 15k Ω , 100pF, Alternately positive or negative	-	-	0/22

Passing Criteria

Item	Symbol	Test Condition	Passing Criteria
Forward Voltage	Vf	500mA	$\Delta V_f < 10\%$
Luminous Flux	Fv	500mA	$\Delta F_v < 30\%$
Chromaticity Coordinates	(x, y)	500mA	$\Delta u'v' < 0.007$

Notes for Table 9:

1. Measurements are performed after allowing the LEDs to return to room temperature
2. T_{sld} : reflow soldering temperature; T_a : ambient temperature

Reflow Characteristics

Figure 12 : Reflow Profile

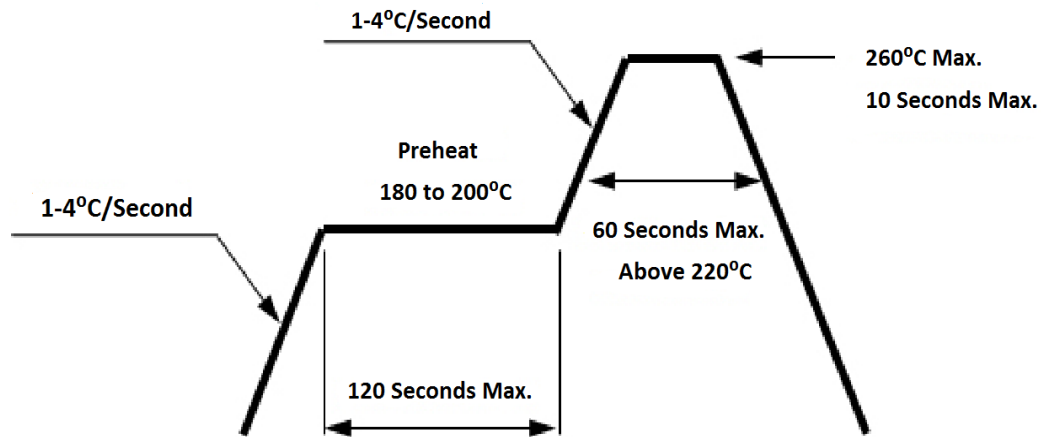

Profile Feature	Lead Free Assembly
Preheat: Temperature Range	180°C – 200°C
Preheat: Time (Maximum)	120 seconds
Peak Temperature	260°C
Soldering Time (Maximum)	10 seconds
Allowable Reflow Cycles	2

Figure 13 : Pick and Place

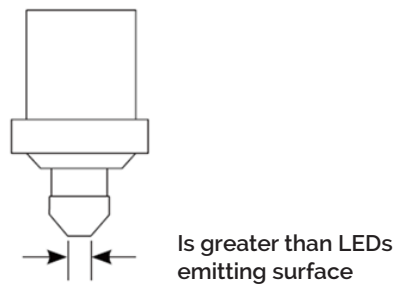

Note for Figure 13:

1. When using a pick and place machine, choose a nozzle that has a larger diameter than the LED's emitting surface. Using a Pick-and-Place nozzle with a smaller diameter than the size of the LEDs emitting surface will cause damage and may also cause the LED to not illuminate.

Packaging

Figure 14: Emitter Reel Drawings

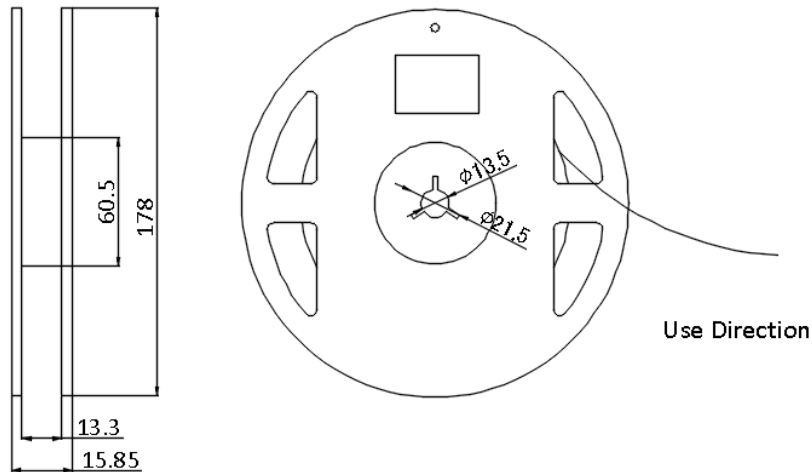

Note for Figure 14:

1. Drawings are not to scale. Drawing dimensions are in millimeters.

Figure 15: Emitter Tape Drawings

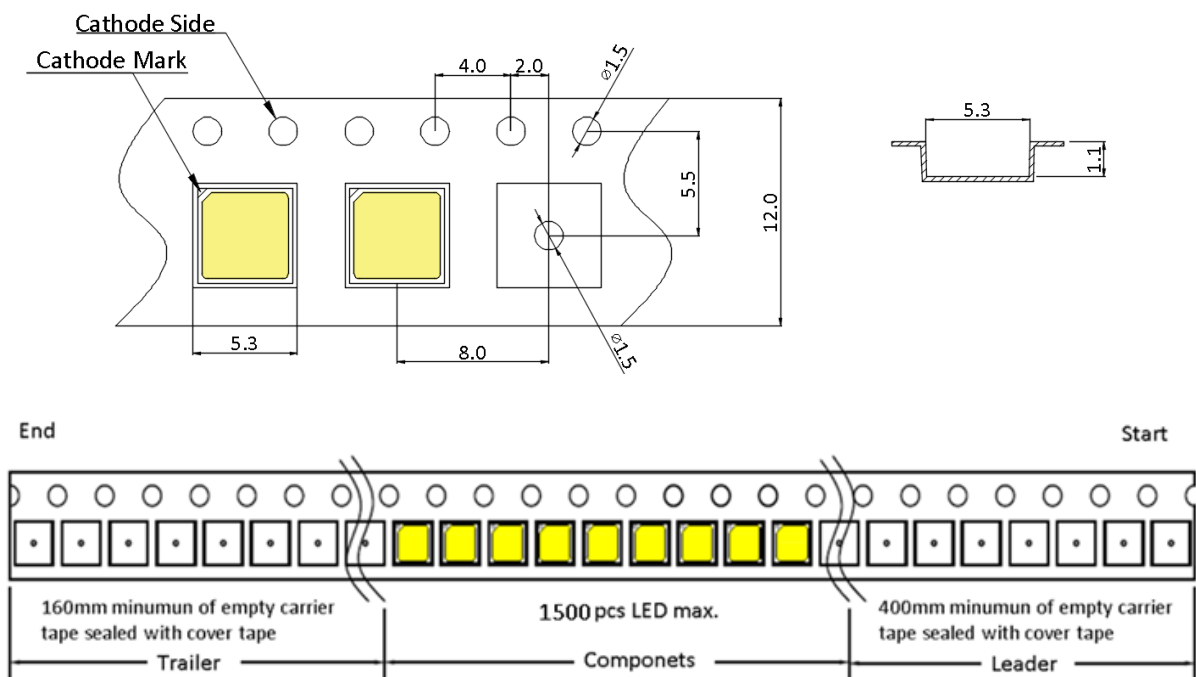

Note for Figure 15:

1. Drawings are not to scale. Drawing dimensions are in millimeters.

Packaging

Figure 16: Emitter Reel Packaging Drawings

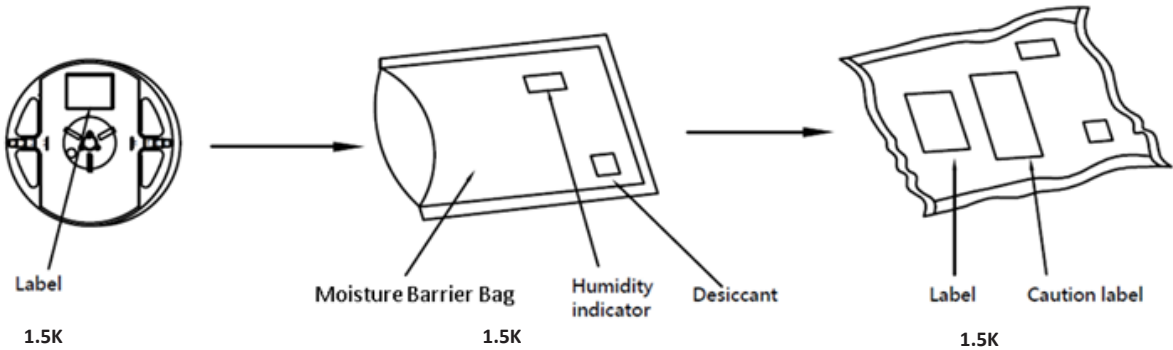

Note for Figure 16:
1. Drawings are not to scale.

Design Resources

Please contact your Bridgelux sales representative for assistance.

Precautions

CAUTION: CHEMICAL EXPOSURE HAZARD

Exposure to some chemicals commonly used in luminaire manufacturing and assembly can cause damage to the LED emitter. Please consult Bridgelux Application Note AN51 for additional information.

CAUTION: EYE SAFETY

Eye safety classification for the use of Bridgelux SMD LED emitter is in accordance with IEC specification EN62471: Photobiological Safety of Lamps and Lamp Systems. SMD LED emitters are classified as Risk Group 2 when operated at or below the maximum drive current. Please use appropriate precautions. It is important that employees working with LEDs are trained to use them safely.

CAUTION: RISK OF BURN

Do not touch the SMD LED emitter during operation. Allow the emitter to cool for a sufficient period of time before handling. The SMD LED emitter may reach elevated temperatures such that could burn skin when touched.

CAUTION

CONTACT WITH LIGHT EMITTING SURFACE (LES)

Avoid any contact with the LES. Do not touch the LES of the emitter or apply stress to the LES (yellow phosphor resin area). Contact may cause damage to the emitter

Optics and reflectors must not be mounted in contact with the LES (yellow phosphor resin area).

Disclaimers

MINOR PRODUCT CHANGE POLICY

The rigorous qualification testing on products offered by Bridgelux provides performance assurance. Slight cosmetic changes that do not affect form, fit, or function may occur as Bridgelux continues product optimization.

STANDARD TEST CONDITIONS

Unless otherwise stated, LED emitter testing is performed at the nominal drive current.

About Bridgelux: Bridging Light and Life™

At Bridgelux, we help companies, industries and people experience the power and possibility of light. Since 2002, we've designed LED solutions that are high performing, energy efficient, cost effective and easy to integrate. Our focus is on light's impact on human behavior, delivering products that create better environments, experiences and returns—both experiential and financial. And our patented technology drives new platforms for commercial and industrial luminaires.

For more information about the company, please visit
bridgelux.com
twitter.com/Bridgelux
facebook.com/Bridgelux
youtube.com/user/Bridgelux
https://www.linkedin.com/company/bridgelux-inc-_2
WeChat ID: BridgeluxInChina



46430 Fremont Boulevard
Fremont, CA 94538.USA
Tel (925) 583-8400
www.bridgelux.com

© 2019 Bridgelux, Inc. All rights reserved 2019. Product specifications are subject to change without notice. Bridgelux and the Bridgelux stylized logo design are registered trademarks of Bridgelux, Inc. All other trademarks are the property of their respective owners.