

## AFBR-57G5AMZ

### 32GFC SFP28 for Multi-Mode Optical Fiber Digital Diagnostic SFP, 850-nm, 32G/16G/8G Low Voltage (3.3V) Fibre Channel Optical Transceiver



#### Description

The Broadcom<sup>®</sup> AFBR-57G5MZ optical transceiver supports high-speed serial links over multi-mode optical fiber at signaling rates up to 28.05 Gb/s (the serial line rate of 32GFC). The product is compliant with Small Form Pluggable industry agreements SFP and SFP28 for mechanical and low-speed electrical specifications. High-speed electrical and optical specifications are compliant with ANSI Fibre Channel FC-PI-6.

The AFBR-57G5MZ is a multi-rate 850-nm transceiver that ensures compliance with FC-PI-6 32GFC, 16GFC, and 8GFC specifications. Per the requirements of 32GFC, internal clock and data recovery (CDR) circuits are present on both electrical input and electrical output of this transceiver. These CDRs lock at 28.05 Gb/s and 14.025 Gb/s (32GFC and 16GFC) but must be bypassed for operation at 8.5 Gb/s (8GFC), accomplished by using two Rate Select inputs to configure transmit and receive sides. The transmitter and receiver can operate at different data rates, as is often seen during Fibre Channel speed negotiation.

Digital diagnostic monitoring information (DMI) is present in the AFBR-57G5MZ per the requirements of SFF-8472, providing real-time monitoring information of transceiver laser, receiver, and environment conditions over an SFF-8431 two-wire serial interface.

#### Features

- Compliant to RoHS directives
- 850-nm Vertical Cavity Surface Emitting Laser (VCSEL)
- Class 1 eye safe per IEC60825-1 and CDRH
- Wide temperature range (0°C to 85°C)
- LC duplex connector optical interface conforming to ANSI TIA/EIA604-10 (FOCIS 10A)
- Diagnostic features per SFF-8472 “Diagnostic Monitoring Interface for Optical Transceivers”
- Real-time monitoring of the following:
  - Transmitter average optical power
  - Received average optical power
  - Laser bias current
  - Temperature
  - Supply voltage
- SFP28 mechanical specifications per SFF-8432
- SFP28 compliant low-speed interface per SFF-8419
- Fibre Channel FC-PI-6 compliant high-speed interface
  - 3200-M5-SN-S, 1600-M5-SN-S, 800-M5-SN-S
  - 3200-M5E-SN-I, 1600-M5E-SN-I, 800-M5E-SN-I
  - 3200-M5F-SN-I, 1600-M5F-SN-I, 800-M5F-SN-I
- Fibre Channel FC-PI-6 compliant optical link distances

#### Applications

- Fibre Channel switches (director, stand-alone, blade)
- Fibre Channel host bus adapters
- Fibre Channel RAID controllers
- Fibre Channel tape drive
- Port side connections
- Inter-switch or inter-chassis aggregated links

## Related Products

- AFCT-57G5MZ: 1310-nm SFP for 32G/16G/8G Fibre Channel
- AFBR-57F5MZ: 850-nm SFP for 16G/8G/4G Fibre Channel
- AFCT-57F5AMZ: 1310-nm SFP for 16G/8G/4G Fibre Channel
- AFBR-57D9AMZ: 850-nm SFP for 8G/4G/2G Fibre Channel
- AFCT-57D5ATPZ: 1310-nm SFP for 8G/4G/2G Fibre Channel
- AFCT-57D5ANPZ: 1310-nm SFP for 8G/4G/2G Fibre Channel
- AFBR-57R5APZ: 850-nm SFP for 4G/2G/1G Fibre Channel
- AFCT-57R5APZ: 1310-nm SFP for 4G/2G/1G Fibre Channel
- AFCT-57R5ATPZ: 1310-nm SFP for 4G/2G/1G Fibre Channel
- AFCT-57R5ANPZ: 1310-nm SFP for 4G/2G/1G Fibre Channel

## Transmitter Section

The transmitter section includes a Transmitter Optical Sub-Assembly (TOSA), laser driver circuit, CDR circuit, and an electrical input stage with variable equalization controls and electrical eye measurement capability. The TOSA contains a 850-nm VCSEL light source with an integral light-monitoring function and imaging optics to ensure efficient optical coupling to the LC connector interface. The TOSA is driven by a laser driver IC, which uses the differential output from an integral Tx CDR stage to modulate and regulate VCSEL optical power. As mandated by FC-PI-6, the integral CDR cleans up any incoming jitter accumulated from the host ASIC, PCB traces, and SFP electrical connector. Between the SFP electrical connector and Tx CDR is a variable, I<sup>2</sup>C controlled, equalization circuit to optimize SFP performance with nonideal incoming electrical waveforms. Note the Tx CDR is engaged with Tx\_RATE=high (32GFC) and autoconfigured (engaged or bypassed) with Tx\_RATE=low (16G/8G).

## Receiver Section

The receiver section includes a Receiver Optical Sub-Assembly (ROSA), pre-amplification and post-amplification circuit, CDR circuit, and an electrical output stage with variable emphasis controls. The ROSA, containing a high-speed PIN detector, pre-amplifier, and imaging optics efficiently couple light from the LC connector interface and perform an optical-to-electrical conversion. The resulting differential electrical signal passes through a post-amplification circuit and into a CDR circuit for cleaning up accumulated jitter.

Note the Rx CDR is engaged with Rx\_RATE=high (32GFC) and autoconfigured (engaged or bypassed) with Rx\_RATE=low (16G/8G).

## Digital Diagnostics

The AFBR-57G5MZ is compliant to the Diagnostic Monitoring Interface (DMI) defined in SFF-8472. These features allow the host to access, using two-wire serial, real-time diagnostic monitors of transmit optical power, received optical power, temperature, supply voltage, and laser operating current.

## Low-Speed Interfaces

Conventional low-speed interface I/Os are available as defined in SFF-8074 and SFF-8431 to manage coarse and fine functions of the optical transceiver. On the transmit side, a Tx\_DISABLE input is provided for the host to turn on and turn off the outgoing optical signal. A transmitter rate select control input, Tx\_RATE, is provided to configure the transmitter stages for 32GFC, 16GFC, or 8GFC operation (logic HIGH reserved for 32GFC, logic LOW reserved for 16GFC and 8GFC). A transmitter fault indicator output, Tx\_FAULT, is available for the SFP to signal a host of a transmitter operational problem. A receiver rate select control input, Rx\_RATE, is provided to configure receiver stages for 32GFC, 16GFC, or 8GFC operation (logic HIGH reserved for 32GFC, logic LOW reserved for 16GFC and 8GFC). A received optical power loss of signal indicator, RX\_LOS, is available to advise the host of a receiver operational problem.

Figure 1: Transceiver Block Diagram

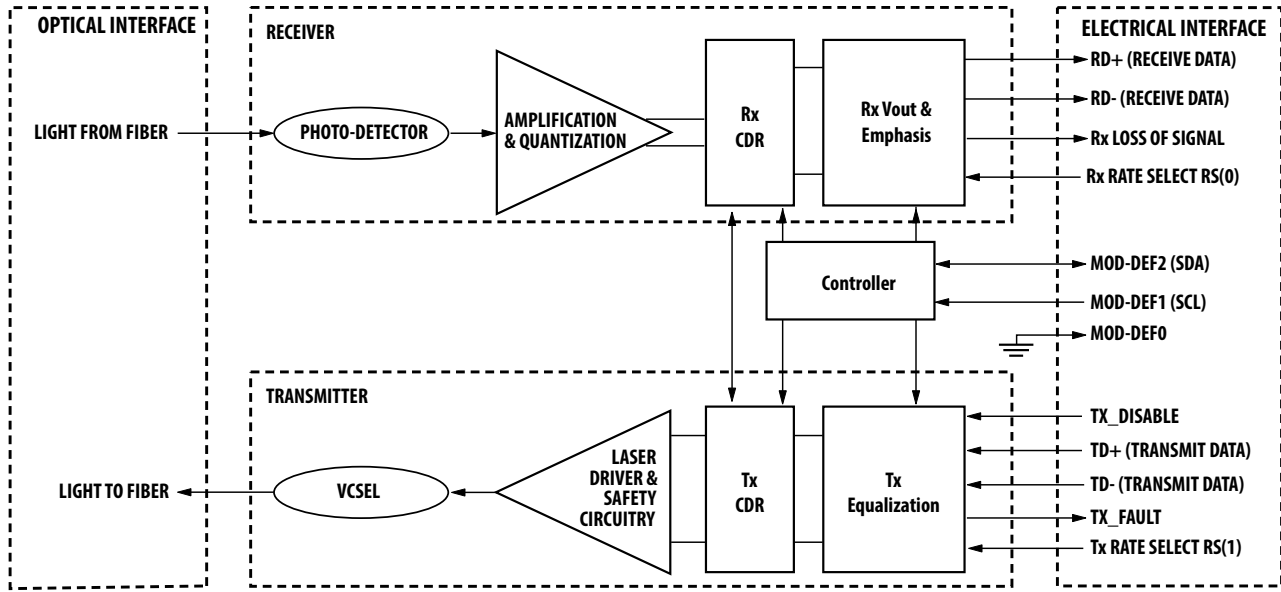

Table 1: Regulatory Compliance Table



Feature	Test Method	Performance
Electrostatic Discharge (ESD) to the Electrical Contacts	JEDEC Human Body Model (HBM) (JESD22-A114-B)	High-speed contacts shall withstand 1000V. All other contacts shall withstand 2000V.
Electrostatic Discharge (ESD) to the Optical Connector Receptacle	EN61000-4-2, Criterion B	When installed in a properly grounded housing and chassis the units are subjected to 15-kV air discharges during operation and 8-kV direct discharges to the case.
Electromagnetic Interference (EMI)	FCC Part 15 CENELEC EN55022 (CISPR 22A) VCCI Class 1	System margins are dependent on customer board and chassis design.
Immunity	Variation of IEC 61000-4-3	Typically shows no measurable effect from a 10-V/m field swept from 80 MHz to 1 GHz applied to the module without a chassis enclosure.
Laser Eye Safety and Equipment Type Testing	US FDA CDRH AEL Class 1 US21 CFP, Subchapter J per Paragraphs 1002.10 and 1002.12 (IEC) EN60825-1:1994 +A11 +A2 (IEC) EN60825-2:1994 +A1 (IEC) EN60950:1992 +A1 +A2 +A3 +A4 +A11	CDRH Certification 9720151-155 TUV File: R72121699
 		
Component Recognition	Underwriters Laboratories (UL) and Canadian Standards Association (CSA) Joint Component Recognition for Information Technology Equipment including Electrical Business Equipment	UL File: E173874
RoHS Compliance		Less than 1000 ppm of cadmium, lead, mercury, hexavalent chromium, polybrominated biphenyls (PBBs) and polybrominated biphenyl ethers (PBDEs).

Figure 2: Typical Application Configuration

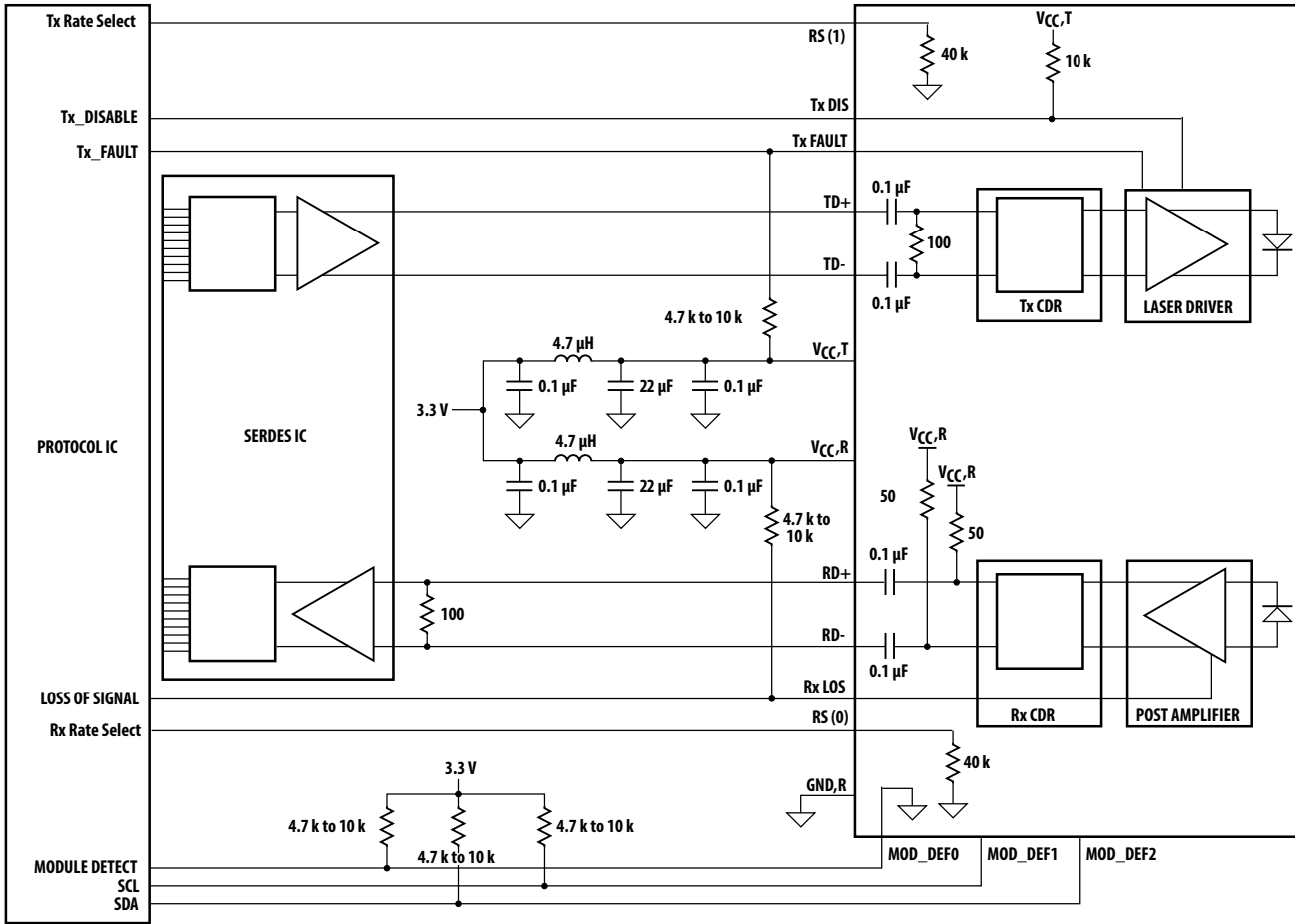
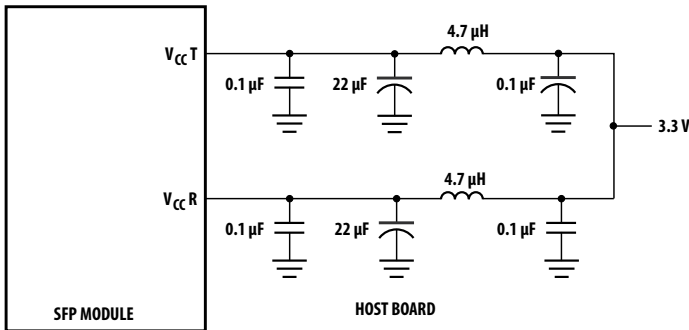

Figure 3: Recommended Power Supply Filter



NOTE: INDUCTORS MUST HAVE LESS THAN 1 SERIES RESISTANCE TO LIMIT VOLTAGE DROP TO THE SFP MODULE.

**Table 2: Pin Description**

Pin	Name	Function/Description	Notes
1	VeeT	Transmitter Ground	
2	TX_FAULT	Transmitter Fault Indication – High indicates a fault condition	a
3	TX_DISABLE	Transmitter Disable – Module optical output disables on high or open	b
4	MOD_SDA	Module Definition 2 – Two-wire serial ID interface data line (SDA)	c
5	MOD_SCL	Module Definition 1 – Two-wire serial ID interface clock line (SCL)	c
6	MOD_ABS	Module Definition 0 – Grounded in module (module present indicator)	c
7	Rx Rate Select, RS(0)	Receiver Rate Select. Logic High = 28.05 Gb/s, Logic Low = 14.025 Gb/s and 8.5 Gb/s	d
8	RX_LOS	Loss of Signal – High indicates loss of received optical signal	e
9	Tx Rate Select, RS(1)	Transmitter Rate Select. Logic High = 28.05 Gb/s, Logic Low = 14.025 Gb/s and 8.5 Gb/s	d
10	VeeR	Receiver Ground	
11	VeeR	Receiver Ground	
12	RD–	Inverse Received Data Out	f
13	RD+	Received Data Out	f
14	VeeR	Receiver Ground	
15	VccR	Receiver Power + 3.3V	g
16	VccT	Transmitter Power + 3.3V	g
17	VeeT	Transmitter Ground	
18	TD+	Transmitter Data In	h
19	TD–	Inverse Transmitter Data In	h
20	VeeT	Transmitter Ground	

- a. TX\_FAULT is an open collector/drain output, which must be pulled up with a 4.7-kΩ to 10-kΩ resistor on the host board. When high, this output indicates a laser fault of some kind. Low indicates normal operation. In the low state, the output is pulled to < 0.8V.
- b. TX\_DISABLE is an input that shuts down the transmitter optical output. It is internally pulled up (within the transceiver) with a 5.6-kΩ resistor.  
 Low (0V to 0.8V): Transmitter on  
 Between (0.8V and 2.0V): Undefined  
 High (2.0V – Vcc max.) or OPEN: Transmitter Disabled
- c. The signals Mod\_ABS, SCL, and SDA designate the two-wire serial interface pins. They must be pulled up with a 4.7-kΩ to 10-kΩ resistor on the host board.  
 Mod\_ABS is grounded by the module to indicate the module is present.  
 Mod\_SCL is serial clock line (SCL) of a two-wire serial interface.  
 Mod\_SDA is serial data line (SDA) of a two-wire serial interface.
- d. RATE\_SELECT is an input that controls transmitter and receiver compliance among multiple rates. It is internally pulled down with a 40-kΩ resistor.  
 Low (0V to 0.8V) or OPEN: Low Bit Rate Compliance (14.025 Gb/s and 8.5 Gb/s)  
 Between (0.8V and 2.0V): Undefined  
 High (2.0V to Vcc max.): High Bit Rate Compliance (28.05 Gb/s)
- e. RX\_LOS (Rx Loss of Signal) is an open collector/drain output that must be pulled up with a 4.7-kΩ to 10-kΩ resistor on the host board. When high, this output indicates the received optical power is below the worst-case receiver sensitivity (as defined by the standard in use). Low indicates normal operation. In the low state, the output is pulled to < 0.8V.
- f. RD–/+ designate the differential receiver outputs. They are AC coupled 100Ω differential lines that should be terminated with 100Ω differential at the host SerDes input. AC coupling is done inside the transceiver and is not required on the host board. The voltage swing on these lines is between 50-mV and 900-mV differential (25-mV to 450-mV single-ended) when properly terminated.
- g. VccR and VccT are the receiver and transmitter power supplies. Refer to SFF-8419 for details.
- h. TD–/+ designate the differential transmitter inputs. They are AC-coupled differential lines with 100Ω differential termination inside the module. The AC coupling is done inside the module and is not required on the host board. The inputs accept differential swings of 40 mV to 1200 mV (20-mV to 600-mV single-ended), although use values between 50-mV and 900-mV differential (25-mV to 450-mV single-ended) for best EMI performance.

Stress in excess of any of the individual [Absolute Maximum Ratings](#) can cause immediate catastrophic damage to the module even if all other parameters are within [Recommended Operating Conditions](#). It should not be assumed that limiting values of more than one parameter can be applied to the module concurrently. Exposure to any of the [Absolute Maximum Ratings](#) for extended periods can adversely affect reliability.

**Table 3: Absolute Maximum Ratings**

Parameter	Symbol	Min.	Max.	Units	Notes
Storage Temperature	$T_S$	-40	85	°C	a
Case Operating Temperature	$T_C$	-40	85	°C	
Relative Humidity	RH	5	95	%	
Supply Voltage	$V_{CC}$	-0.5	3.6	V	
Low Speed Input Voltage	$V_I$	-0.5	$V_{CC} + 0.5, 3.63$	V	

- a. [Absolute Maximum Ratings](#) are those values beyond which damage to the device may occur if these limits are exceeded for other than a short period of time. Refer to the reliability data sheet for specific reliability performance. Between [Absolute Maximum Ratings](#) and the [Recommended Operating Conditions](#), functional performance is not intended, device reliability is not implied, and damage to the device may occur over an extended period of time.

[Recommended Operating Conditions](#) specify parameters for which the optical and electrical characteristics hold unless otherwise noted. Optical and electrical characteristics are not defined for operation outside the [Recommended Operating Conditions](#), reliability is not implied, and damage to the module may occur for such operation over an extended period of time.

**Table 4: Recommended Operating Conditions**

Parameter	Symbol	Min.	Typ.	Max.	Units	Notes
Case Operating Temperature	$T_C$	0	—	85	°C	a
Supply Voltage	$V_{CC}$	3.135	3.3	3.465	V	
Data Rate		8.5	—	28.05	Gb/s	b
Two-Wire Serial (TWS) Interface Clock Rate		—	—	400	kHz	c

- a. The position of case temperature measurement is shown in [Figure 7](#). Continuous operation at the maximum recommended case operating temperature should be avoided so as not to degrade reliability.
- b. 32GFC requires FEC RS(528,514) encoding per FC-PI-6. 16GFC and 8GFC are not compatible with FEC, per FC-PI-5.
- c. With 500- $\mu$ s clock stretch per SFF-8419.

The following characteristics are defined over the [Recommended Operating Conditions](#) unless otherwise noted.

**Table 5: Transceiver Electrical Characteristics**

Parameter	Symbols	Min.	Typ.	Max.	Units	Notes
Transceiver Power Consumption		—	—	1.0	W	
Transceiver Power Supply Current		—	—	319	mA	
Power Supply Noise Rejection (peak-peak)	PSNR	—	—	66	mVpp	a
TX_FAULT, RX_LOS	$I_{OH}$	-50	—	37.5	$\mu$ A	b
	$V_{OL}$	-0.3	—	0.4	V	
TX_DIS, RS0, RS1	$V_{IH}$	2.0	—	$V_{CC} + 0.3$	V	
	$V_{IL}$	-0.3	—	0.8	V	
MOD_SCL, MOD_SDA	$V_{OH}$	$V_{CC\_Hst} - 0.5$	—	$V_{CC\_Hst} + 0.3$	V	c
	$V_{OL}$	0.0	—	0.4	V	
	$V_{IH}$	$V_{CC} \times 0.7$	—	$V_{CC} + 0.5$	V	
	$V_{IL}$	-0.3	—	$V_{CC} \times 0.3$	V	

- Filter per SFF-8419 specification is required on the host board.
- Measured with a 4.7-k $\Omega$  load pulled up to the host board to 3.3V.
- Mod\_SCL and Mod\_SDA must be pulled up externally with a 4.7-k $\Omega$  to 10-k $\Omega$  resistor on the host board to host  $V_{CC}$  ( $3.14 < V_{CC\_Hst} < 3.46V$ ).

$T_C = 0^\circ\text{C}$  to  $70^\circ\text{C}$ ,  $V_{ccT}$ ,  $V_{ccR} = 3.3\text{V} \pm 5\%$ .

**Table 6: Transmitter and Receiver Electrical Characteristics**

Parameter	Symbol	Min.	Max.	Units	Notes
High-Speed Data Input Transmitter Differential Input Voltage (TD+/-)	$V_I$	50	900	mV	Note <sup>a</sup>
High-Speed Data Output Receiver Differential Output Voltage (RD+/-)	$V_O$	250	900	mV	Note <sup>b</sup>
Module Electrical Input, Differential Termination Resistance Mismatch		—	10	%	
Module Electrical Input Differential Return Loss SDD11		—	—		See FC-PI-6 Equation 6-1, Figure 10
Module Electrical Input Common Mode to Differential Conversion, SCD11		—	—		See FC-PI-6 Equation 6-2, Figure 12
Module Electrical Input, Differential Mode to Common Conversion, SDC11		—	—		See FC-PI-6 Equation 6-2, Figure 12
Module Electrical Input, Stressed Input Random Jitter, p-p, 10E-6 BER		—	0.09	UI	
Module Electrical Input, Stressed Input Eye Width at 1E-6 Probability EW6		0.46	—	UI	
Module Electrical Input, Stressed Input Eye Height at 1E-6 Probability EH6		50	—	mV	
Module Electrical Output, Common Mode Noise rms		—	17.5	mV,rms	
Module Electrical Output, Differential Termination Resistance Mismatch		—	10	%	
Module Electrical Output, Differential Return Loss SDD22		—	—		See FC-PI-6 Equation 6-1, Figure 10
Module Electrical Output, Common Mode to Differential Conversion, SCD22		—	—		See FC-PI-6 Equation 6-3, Figure 12
Module Electrical Output, Differential Mode to Common Conversion, SDC22		—	—		See FC-PI-6 Equation 6-3, Figure 12
Module Electrical Output, Common Mode Return Loss, SCC22		—	-2	dB	
Module Electrical Output, Vertical Eye Closure		—	4	dB	
Module Electrical Output, Eye Width at 1E-6 Probability EW6		0.65	—	UI	
Module Electrical Output, Eye Height at 1E-6 Probability EH12		250	—	mV	
Receiver Total Jitter (28.05 Gb/s)	TJ	—	—	UI	Compliance Test. Notes <sup>c, d</sup>
Receiver Total Jitter (14.025 Gb/s)	TJ	—	0.36	UI	Note <sup>c</sup>
Receiver Total Jitter (8.5 Gb/s)	TJ	—	0.71	UI	Note <sup>e</sup>
Receiver Deterministic Jitter (14.025 Gb/s)	DJ	—	0.22	UI	Note <sup>c</sup>
Receiver Deterministic Jitter (8.5 Gb/s)	DJ	—	0.42	UI	Note <sup>e</sup>



**Table 6: Transmitter and Receiver Electrical Characteristics (Continued)**

Parameter	Symbol	Min.	Max.	Units	Notes
Receiver Data Dependent Pulse Width Shrinkage (14.025 Gb/s)	DDPWS	—	0.14	UI	Note <sup>c</sup>
Receiver Data Dependent Pulse Width Shrinkage (8.5 Gb/s)	DDPWS	—	0.36	UI	Note <sup>e</sup>

- Internally AC coupled and terminated (100Ω differential).
- Internally AC coupled but requires an external load termination (100Ω differential).
- CDR is engaged with 28.05 Gb/s and 14.025 Gb/s.
- 32GFC (28.05 Gb/s) assumes an FEC encoded RS(528, 514) signal and allows a BER of 1E–6 for receiver and transmitter measurements.
- CDR is not engaged with 8.5 Gb/s.

$T_C = 0^\circ\text{C}$  to  $70^\circ\text{C}$ ,  $V_{ccT}$ ,  $V_{ccR} = 3.3\text{V} \pm 5\%$ .

**Table 7: Transmitter Optical Characteristics**

Parameter	Symbol	Min.	Typ.	Max.	Units	Notes
Modulated Optical Output Power (OMA) (Peak to Peak) 28.05 Gb/s	Tx,OMA	479	—	—	μW	
Modulated Optical Output Power (OMA) (Peak to Peak) 14.025 Gb/s	Tx,OMA	331	—	—	μW	
Modulated Optical Output Power (OMA) (Peak to Peak) 8.5 Gb/s	Tx,OMA	302	—	—	μW	
Average Optical Output Power 28.05 Gb/s	Pout	–6.2	—	—	dBm	a
Average Optical Output Power 14.025 Gb/s	Pout	–7.8	—	—	dBm	a
Average Optical Output Power 8.5 Gb/s	Pout	–8.2	—	—	dBm	a
Center Wavelength	$\lambda_c$	840	—	860	nm	
Spectral Width – rms	$\sigma_{rms}$	—	—	0.57	nm	
RIN12 (OMA)	RIN	—	—	–129	dB/Hz	
Optical Return Loss Tolerance		—	—	12	dB	
Vertical Eye Closure Penalty, 28.05 Gb/s	VECP	—	—	3.13	dB	b
Vertical Eye Closure Penalty, 14.025 Gb/s	VECP	—	—	2.56	dB	b
Transmitter Waveform Distortion Penalty, 8.5 Gb/s	TWDP	—	—	4.3	dB	c
Pout Tx_DISABLE Asserted	Poff	—	—	–35	dBm	

- Max Pout is the lesser of Class 1 safety limits (CDRH and EN 60825) or received power, max.
- CDR is engaged with 28.05 Gb/s and 14.025 Gb/s.
- CDR is not engaged with 8.5 Gb/s.

$T_C = 0\text{ }^{\circ}\text{C}$  to  $70\text{ }^{\circ}\text{C}$ ,  $V_{ccT}$ ,  $V_{ccR} = 3.3\text{V} \pm 5\%$ .

**Table 8: Receiver Optical and Electrical Characteristics**

Parameter	Symbol	Min.	Typ.	Max.	Units	Notes
Optical Input Power, 28.05 Gb/s	$P_{IN}$	—	—	+2	dBm,avg	
Optical Input Power, 14.025 Gb/s and 8.5 Gb/s	$P_{IN}$	—	—	0	dBm,avg	
Input Optical Modulation Amplitude, 28.05 Gb/s (Peak to Peak) (Unstressed Sensitivity)	OMA	95	—	—	$\mu\text{W}$ ,OMA	a, 5
Input Optical Modulation Amplitude, 14.025 Gb/s (Peak to Peak) (Unstressed Sensitivity)	OMA	89	—	—	$\mu\text{W}$ ,OMA	a
Input Optical Modulation Amplitude, 8.5 Gb/s (Peak to Peak) (Unstressed Sensitivity)	OMA	76	—	—	$\mu\text{W}$ ,OMA	a
Stressed Receiver Sensitivity (OMA) 28.05 Gb/s		263	—	—	$\mu\text{W}$ ,OMA	b, c
Stressed Receiver Sensitivity (OMA) 14.025 Gb/s		170	—	—	$\mu\text{W}$ ,OMA	d
Stressed Receiver Sensitivity (OMA) 8.5 Gb/s		151	—	—	$\mu\text{W}$ ,OMA	e
Return Loss		12	—	—	dB	
Loss of Signal – Assert	$P_A$	-30	—	—	dBm,avg	
Loss of Signal – Deasserted	$P_D$	—	—	-9.1	dBm,avg	
Loss of Signal – Hysteresis	$P_A - P_D$	0.5	—	—	dB	

- a. Input optical modulation amplitude (commonly known as sensitivity) requires a valid Fibre Channel encoded input.
- b. 28.05-Gb/s stressed received vertical eye closure penalty (ISI) min is 3.1 dB.
- c. 32GFC (28.05 Gb/s) assumes an FEC-encoded RS(528, 514) signal and allows a BER of  $1\text{E}-6$  for receiver and transmitter measurements.
- d. 14.025-Gb/s stressed received vertical eye closure penalty (ISI) min is 2.5 dB.
- e. 8.5 Gb/s stressed received vertical eye closure penalty (ISI) min is 3.1 dB.

**Table 9 Rate Select Definition**

Function	State	Operation
Tx Rate Select RS(1)	High	Transmit Rate Select HIGH is defined for 32GFC operation. It configures the Tx CDR to lock on 28.05-Gb/s 64b/66b encoded data and sets the Tx optical power and linear bandwidth for 32GFC operation. FEC is expected for 32GFC.
	Low	Transmit Rate Select LOW autoconfigures the internal Tx CDR for 16GFC (CDR locked) or 8GFC (CDR bypassed) operation. Transmit optical power and linear bandwidth are optimized accordingly. FEC is not expected for 16GFC or 8GFC. This is intended for use only with 16GFC and 8GFC traffic.
Rx Rate Select RS(0)	High	Receive Rate Select HIGH is defined for 32GFC operation. It configures the Rx CDR to lock on 28.05 Gb/s 64b/66b encoded data and sets the Rx optical sensitivity and bandwidth for 32GFC operation. FEC is expected for 32GFC.
	Low	Receive Rate Select LOW auto configures the internal Rx CDR for 16GFC (CDR locked) or 8GFC (CDR bypassed) operation. Receiver optical sensitivity and linear bandwidth are optimized accordingly. FEC is not expected for 16GFC or 8GFC. This is intended for use only with 16GFC and 8GFC traffic; however, when the CDR is bypassed, the SFP behaves like a legacy SFP (and is not bit-rate sensitive).

**NOTE:** During Fibre Channel link speed negotiation sequences, the host controls the Tx Rate and Rx Rate inputs separately to accomplish link initialization. When speed negotiation is complete, it is expected that both Tx Rate and Rx Rate are placed in the same state by the host.

# Rate Select Control

RX and TX rates can be independently controlled by either hardware input pins or using register writes. Module electrical input pins 7 and 9 are used to select RX and TX rates, respectively. The status of each logic level is reflected to register byte 110 bits 4 and 5 on address A2h as shown in the following figures. RX and TX rates can also be controlled using register writes to bytes 110 bit 3 and 118 bit 3. The power-on default of these bits is logic low. Hardware and software control inputs are ORed to allow flexible control.

Figure 4: RS0 RX Rate Select Control Flow

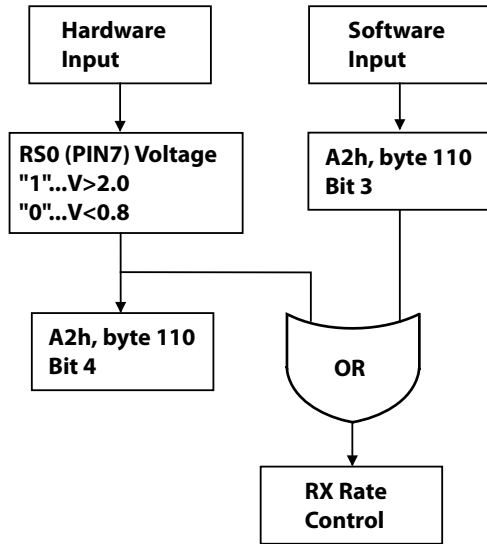
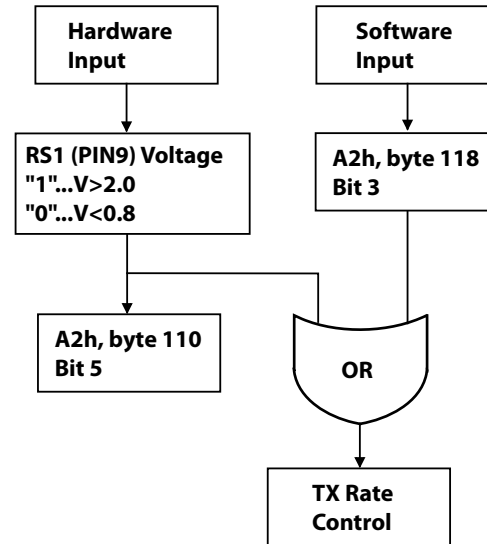

Figure 5: RS1 TX Rate Select Control Flow



RS0 Control Input		RX Operation	
Hardware	Software		
0	0	16G/8G FC	Rx CDR autodetect
0	1	32GFC	Rx CDR engaged
1	0	32GFC	Rx CDR engaged
1	1	32GFC	Rx CDR engaged

RS1 Control Input		TX Operation	
Hardware	Software		
0	0	16G/8G FC	Tx CDR autodetect
0	1	32GFC	Tx CDR engaged
1	0	32GFC	Tx CDR engaged
1	1	32GFC	Tx CDR engaged

$T_C = -10\text{ }^{\circ}\text{C}$  to  $70\text{ }^{\circ}\text{C}$ ,  $V_{ccT}$ ,  $V_{ccR} = 3.3\text{V} \pm 5\%$ .

**Table 10: Transceiver SOFT DIAGNOSTIC Timing Characteristics**

Parameter	Symbol	Min.	Max.	Units	Notes
Hardware TX_DISABLE Assert Time	t_off	—	100	μs	a
Hardware TX_DISABLE Negate Time	t_on	—	2	ms	b
Time to initialize, including reset of TX_FAULT	t_init	—	300	ms	c
Hardware TX_FAULT Assert Time	t_fault	—	1	ms	d
Hardware TX_DISABLE to Reset	t_reset	10	—	μs	e
Hardware RX_LOS Deassert Time	t_loss_on	—	100	μs	f
Hardware RX_LOS Assert Time	t_loss_off	—	100	μs	g
Hardware RATE_SELECT Assert Time	t_rate_high	—	2	ms	h
Hardware RATE_SELECT Deassert Time	t_rate_low	—	2	ms	h
Software TX_DISABLE Assert Time	t_off_soft	—	100	ms	i
Software TX_DISABLE Negate Time	t_on_soft	—	100	ms	j
Software Tx_FAULT Assert Time	t_fault_soft	—	100	ms	k
Software Rx_LOS Assert Time	t_loss_on_soft	—	100	ms	l
Software Rx_LOS Deassert Time	t_loss_off_soft	—	100	ms	m
Software RATE_SELECT Assert Time	t_rate_soft_high	—	100	ms	n
Software RATE_SELECT Deassert Time	t_rate_soft_low	—	100	ms	o
Analog Parameter Data Ready	t_data	—	1000	ms	p
Serial Bus Hardware Ready	t_serial	—	300	ms	q
Serial Bus Buffer Time	t_buf	20	—	μs	r
Complete Single or Sequential Write Up to 4 Bytes	twR	—	40	ms	s
Complete Sequential Write of 5 to 8 Bytes	twR	—	80	ms	
Serial Interface Clock Holdoff "Clock Stretching"	T_clock_hold	—	500	μs	t
Serial ID Clock Rate	f_serial_clock	—	400	kHz	u

- a. Time from rising edge of TX\_DISABLE to when the optical output falls below 10% of nominal.
- b. Time from falling edge of TX\_DISABLE to when the modulated optical output rises above 90% of nominal.
- c. Time from power-on or falling edge of Tx\_Disable to when the modulated optical output rises above 90% of nominal.
- d. From occurrence of fault to assertion of TX\_FAULT.
- e. Time TX\_DISABLE must be held high to reset the laser fault shutdown circuitry.
- f. Time from loss of optical signal to Rx\_LOS Assertion.
- g. Time from valid optical signal to Rx\_LOS Deassertion.
- h. Time from rising or falling edge of Rate\_Select input until transceiver is successfully passing traffic as designated by RS(0) and RS(1). For Rate\_Select going high, the internal CDR locks on valid 32GFC encoded data within the specified time. For Rate\_Select going low, the internal CDR attempts to lock on valid 16GFC encoded data for a certain gating period. If valid 16GFC data is not detected in that gating period, the internal CDR is automatically bypassed for use at 8GFC rates.
- i. Time from two-wire interface assertion of TX\_DISABLE (A2h, byte 110, bit 6) to when the optical output falls below 10% of nominal. Measured from falling clock edge after stop bit of write transaction.
- j. Time from two-wire interface deassertion of TX\_DISABLE (A2h, byte 110, bit 6) to when the optical output rises above 90% of nominal.
- k. Time from fault to two-wire interface TX\_FAULT (A2h, byte 110, bit 2) asserted.
- l. Time for two-wire interface assertion of Rx\_LOS (A2h, byte 110, bit 1) from loss of optical signal.

- m. Time for two-wire interface deassertion of Rx\_LOS (A2h, byte 110, bit 1) from presence of a valid optical signal.
- n. Time from two-wire interface assertion of Rate\_Select (either RS(0) in A2h, byte 110, bit 3 or RS(1) in A2h, byte 118, bit 3) to when the respective CDR is engaged at 32GCFC data rate.
- o. Time from two-wire interface deassertion of Rate\_Select (either RS(0) in A2h, byte 110, bit 3 or RS(1) in A2h, byte 118, bit 3) to when the respective CDR is either engaged at 16GCFC data rate or bypassed for 8GFC operation.
- p. From power-on to data ready bit asserted (A2h, byte 110, bit 0). Data ready indicates analog monitoring circuitry is functional.
- q. Time from power-on until the module is ready for data transmission over the serial bus (reads or writes over A0h and A2h).
- r. Time between START and STOP commands.
- s. Time from stop bit to completion of a 1- to 8-byte write command.
- t. Maximum time the SFP+ module may hold the SCL line low before continuing with a read or write operation.
- u. With a maximum clock stretch of 500  $\mu$ s. A maximum of 100-kHz operation can be supported without a clock stretch.

$T_C = -15\text{ }^\circ\text{C}$  to  $85\text{ }^\circ\text{C}$ ,  $V_{CCT}$ ,  $V_{CCR} = 3.3\text{V} \pm 10\%$ .

**Table 11: Transceiver Digital Diagnostic Monitor (Real-Time Sense) Characteristics**

Parameter	Symbol	Min.	Units	Notes
Transceiver Internal Temperature Accuracy	$T_{INT}$	$\pm 3.0$	$^\circ\text{C}$	Temperature is measured internal to the transceiver. Valid from $0^\circ\text{C}$ to $70^\circ\text{C}$ case temperature.
Transceiver Internal Supply Voltage Accuracy	$V_{INT}$	$\pm 0.1$	V	Supply voltage is measured internal to the transceiver and can, with less accuracy, be correlated to voltage at the SFP $V_{CC}$ pin. Valid over $3.3\text{V} \pm 5\%$ .
Transmitter Laser DC Bias Current Accuracy	$I_{INT}$	$\pm 10$	%	$I_{INT}$ is better than $\pm 10\%$ of the nominal value.
Transmitted Average Optical Output Power Accuracy	$P_T$	$\pm 3.0$	dB	Coupled into 50- $\mu\text{m}$ multi-mode fiber. Valid from $-8.2\text{ dBm}$ to $+2\text{ dBm}$ avg.
Received Optical Input Power Accuracy	$P_R$	$\pm 3.0$	dB	Coupled from 50- $\mu\text{m}$ multi-mode fiber. Valid from $-10.3\text{ dBm}$ to $+2\text{ dBm}$ avg.

Figure 6: Transceiver Timing Diagrams (Module Installed Except Where Noted)

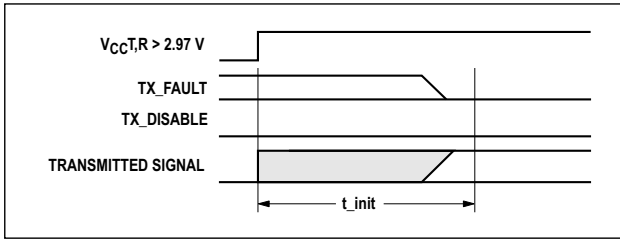

t-init: TX DISABLE NEGATED

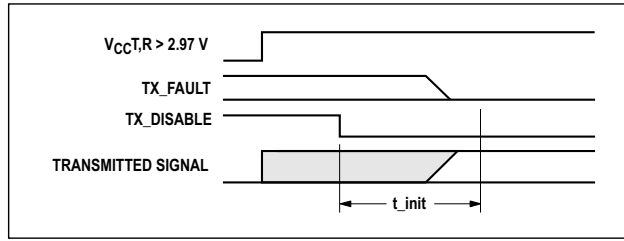

t-init: TX DISABLE ASSERTED

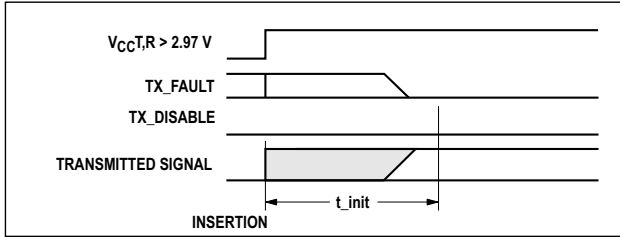

t-init: TX DISABLE NEGATED, MODULE HOT PLUGGED

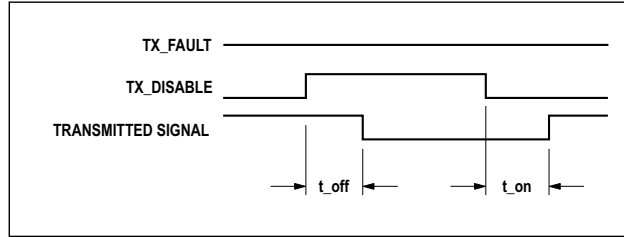

t-off & t-on: TX DISABLE ASSERTED THEN NEGATED

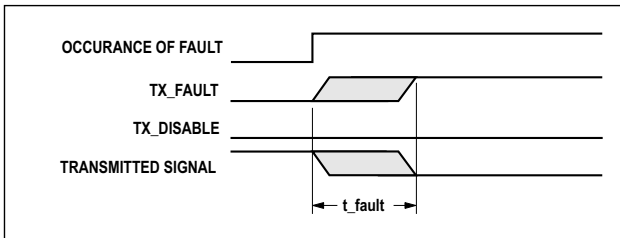

t-fault: TX FAULT ASSERTED, TX SIGNAL NOT RECOVERED

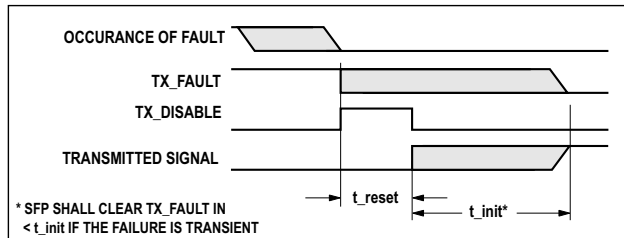

t-reset: TX DISABLE ASSERTED THEN NEGATED, TX SIGNAL RECOVERED

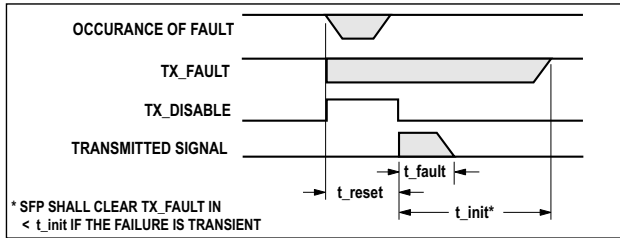

t-fault: TX DISABLE ASSERTED THEN NEGATED, TX SIGNAL NOT RECOVERED

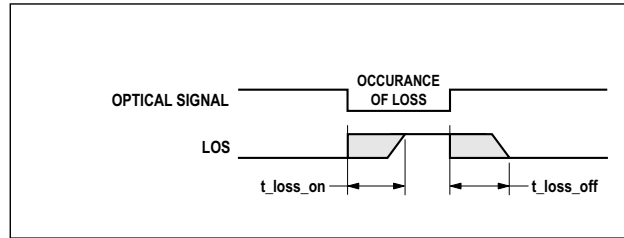

t-loss-on & t-loss-off

Table 12: EEPROM Serial ID Memory Contents – Address A0h

Byte Number Decimal	Hex	Description	Byte Number Decimal	Hex	Description
0	03	SFP physical device	37	00	Hex Byte of Vendor OUI <sup>a</sup>
1	04	SFP function defined by serial ID only	38	17	Hex Byte of Vendor OUI <sup>a</sup>
2	07	LC optical connector	39	6A	Hex Byte of Vendor OUI <sup>a</sup>
3	00		40	41	"A" – Vendor Name ASCII Character
4	00		41	46	"F" – Vendor Name ASCII Character
5	00		42	42	"B" – Vendor Name ASCII Character
6	00		43	52	"R" – Vendor Name ASCII Character
7	60	Short and Intermediate link distance (per FC-PI-6)	44	2D	"-" – Vendor Name ASCII Character
8	40	Shortwave laser without OFC (open fiber control)	45	35	"5" – Vendor Name ASCII Character
9	04	Multi-mode 50- $\mu$ m optical media	46	37	"7" – Vendor Name ASCII Character " "
10	68	800, 1600, and 3200 MB/s FC-PI-6 speed <sup>b</sup>	47	47	G" – Vendor Name ASCII Character " "
11	06	64B/66B data at 32GFC/16GFC and 8B/10B at 8GFC	48	35	"5" – Vendor Name ASCII Character
12	FF	Greater than 25.5 Gb/s (see Address 66)	49	41	"A" – Vendor Name ASCII Character
13	0C	Rate Select (High=32GFC, Low=16GFC, 8GFC)	50	4D	"M" – Vendor Name ASCII Character
14	00		51	5A	"Z" – Vendor Name ASCII Character
15	00		52	20	" " – Vendor Name ASCII Character
16	02	20m of OM2 50/125- $\mu$ m distance at 32GFC <sup>c</sup>	53	20	" " – Vendor Name ASCII Character
17	00	Unspecified OM1 62.5/125- $\mu$ m distance at 32GFC <sup>d</sup>	54	20	" " – Vendor Name ASCII Character
18	0A	100m of OM4 50/125- $\mu$ m fiber at 32GFC <sup>e</sup>	55	20	" " – Vendor Name ASCII Character
19	07	70m of OM3 50/125- $\mu$ m fiber at 32GFC <sup>f</sup>	56	20	" " – Vendor Name ASCII Character
20	41	"A" – Vendor Name ASCII Character	57	20	" " – Vendor Name ASCII Character
21	56	"V" – Vendor Name ASCII Character	58	20	" " – Vendor Name ASCII Character
22	41	"A" – Vendor Name ASCII Character	59	20	" " – Vendor Name ASCII Character
23	47	"G" – Vendor Name ASCII Character	60	03	Hex Byte of Laser Wavelength <sup>g</sup>
24	4F	"O" – Vendor Name ASCII Character	61	52	Hex Byte of Laser Wavelength <sup>g</sup>
25	20	" " – Vendor Name ASCII Character	62	00	
26	20	" " – Vendor Name ASCII Character	63		Checksum for Bytes 0 to 62 <sup>h</sup>
27	20	" " – Vendor Name ASCII Character	64	08	CDRs present. 1W power class
28	20	" " – Vendor Name ASCII Character	65	3A	Hardware Tx_Disable, Tx_Fault, Rx_LOS, Rate_Select
29	20	" " – Vendor Name ASCII Character	66	70	28.050-Gb/s nominal bit rate (32GFC)
30	20	" " – Vendor Name ASCII Character	67	00	
31	20	" " – Vendor Name ASCII Character	68–83		Vendor Serial Number ASCII characters <sup>i</sup>
32	20	" " – Vendor Name ASCII Character	84–91		Vendor Date Code ASCII characters <sup>j</sup>
33	20	" " – Vendor Name ASCII Character	92	68	Digital diagnostics, Internal Cal, Rx Pwr Avg

**Table 12: EEPROM Serial ID Memory Contents – Address A0h (Continued)**

Byte Number Decimal	Hex	Description	Byte Number Decimal	Hex	Description
34	20	" " – Vendor Name ASCII Character	93	FA	Alarms/Warnings, Software Tx_Disable, Tx-Fault, Rx_LOS, Rate_Select
35	20	" " – Vendor Name ASCII Character	94	08	SFF-8472 compliance to revision 12.2
36	00		95		Checksum for Bytes 62 to 94 <sup>h</sup>
			96–255	00	

- a. The IEEE Organizationally Unique Identified (OUI) assigned to Broadcom is 00-17-6A (3 bytes of hex).
- b. FC-PI-6 speed 3200 MB/s is a serial bit rate of 28.05 Gb/s using FEC encoded data (RS 528/514). FC-PI-5 speed 1600 MB/s is a serial bit rate of 14.025 Gb/s. 800 MB/s is a serial bit rate of 8.5 Gb/s.
- c. Link distance with OM2 50/125- $\mu$ m cable at 16GFC is 35m and at 8GFC is 50m.
- d. Link distance with OM1 62.5/125- $\mu$ m cable at 8.5Gb/s is 25m (and is unspecified at 16GFC).
- e. Link distance with OM4 50/125- $\mu$ m cable at 16GFC is 125m and at 8GFC is 190m.
- f. Link distance with OM3 50/125- $\mu$ m cable at 16GFC is 100m and at 8GFC is 150m.
- g. Laser wavelength is represented in 16 unsigned bits. The hex representation of 850 nm is 0352.
- h. Addresses 63 and 95 are checksums calculated (per SFF-8472 and SFF-8074) and stored prior to product shipment.
- i. Addresses 68–83 specify the AFBR-57G5MZ ASCII serial number and vary on a per-unit basis.
- j. Addresses 84–91 specify the AFBR-57G5MZ ASCII data code and vary on a per-date code basis.

**Table 13: EEPROM Serial ID Memory Contents – Enhanced SFP Memory (Address A2h)**

Byte Number Decimal	Notes	Byte Number Decimal	Notes	Byte Number Decimal	Notes
0	Temp H Alarm MSB <sup>a</sup>	26	Tx Power L Alarm MSB <sup>g</sup>	104	Real Time Rx Power MSB <sup>b</sup>
1	Temp H Alarm LSB <sup>a</sup>	27	Tx Power L Alarm LSB <sup>g</sup>	105	Real Time Rx Power LSB <sup>b</sup>
2	Temp L Alarm MSB <sup>a</sup>	28	Tx Power H Warning MSB <sup>g</sup>	106	Reserved
3	Temp L Alarm LSB <sup>a</sup>	29	Tx Power H Warning LSB <sup>g</sup>	107	Reserved
4	Temp H Warning MSB <sup>a</sup>	30	Tx Power L Warning MSB <sup>g</sup>	108	Reserved
5	Temp H Warning LSB <sup>a</sup>	31	Tx Power L Warning LSB <sup>g</sup>	109	Reserved
6	Temp L Warning MSB <sup>a</sup>	32	Rx Power H Alarm MSB <sup>b</sup>	110	Status/Control – See <a href="#">Table 14</a>
7	Temp L Warning LSB <sup>a</sup>	33	Rx Power H Alarm LSB <sup>b</sup>	111	Status/Control – See <a href="#">Table 15</a>
8	Vcc H Alarm MSB <sup>c</sup>	34	Rx Power L Alarm MSB <sup>b</sup>	112	Flag Bits – See <a href="#">Table 16</a>
9	Vcc H Alarm LSB <sup>c</sup>	35	Rx Power L Alarm LSB <sup>b</sup>	113	Flag Bits – See <a href="#">Table 16</a>
10	Vcc L Alarm MSB <sup>c</sup>	36	Rx Power H Warning MSB <sup>b</sup>	114	Tx Input EQ Control – See <a href="#">Table 19</a> , <a href="#">Table 20</a>
11	Vcc L Alarm LSB <sup>c</sup>	37	Rx Power H Warning LSB <sup>b</sup>	115	Rx Output Emphasis Control See <a href="#">Table 21</a> , <a href="#">Table 22</a>
12	Vcc H Warning MSB <sup>c</sup>	38	Rx Power L Warning MSB <sup>b</sup>	116	Flag Bits – See <a href="#">Table 16</a>
13	Vcc H Warning LSB <sup>c</sup>	39	Rx Power L Warning LSB <sup>b</sup>	117	Flag Bits – See <a href="#">Table 16</a>
14	Vcc L Warning MSB <sup>c</sup>	40–55	Optional Alarm and Warning	118	Status/Control – See <a href="#">Table 17</a>
15	Vcc L Warning LSB <sup>c</sup>	56–94	External Calibration Constants <sup>d</sup>	119	CDR Loss of Lock Status – See <a href="#">Table 18</a>



**Table 13: EEPROM Serial ID Memory Contents – Enhanced SFP Memory (Address A2h) (Continued)**

Byte Number Decimal	Notes	Byte Number Decimal	Notes	Byte Number Decimal	Notes
16	Tx Bias H Alarm MSB <sup>e</sup>	95	Checksum for Bytes 0 to 94 <sup>f</sup>	120–126	Reserved
17	Tx Bias H Alarm LSB <sup>e</sup>	96	Real Time Temperature MSB <sup>a</sup>	127	Page Select Control
18	Tx Bias L Alarm MSB <sup>e</sup>	97	Real Time Temperature LSB <sup>a</sup>	128–247	Customer Writable
19	Tx Bias L Alarm LSB <sup>e</sup>	98	Real Time Vcc MSB <sup>c</sup>	248–255	Vendor Specific
20	Tx Bias H Warning MSB <sup>e</sup>	99	Real Time Vcc LSB <sup>c</sup>		
21	Tx Bias H Warning LSB <sup>e</sup>	100	Real Time Tx Bias MSB <sup>e</sup>		
22	Tx Bias L Warning MSB <sup>e</sup>	101	Real Time Tx Bias LSB <sup>e</sup>		
23	Tx Bias L Warning LSB <sup>e</sup>	102	Real Time Tx Power MSB <sup>g</sup>		
24	Tx Power H Alarm MSB <sup>g</sup>	103	Real Time Tx Power LSB <sup>g</sup>		
25	Tx Power H Alarm LSB <sup>g</sup>				

- Temperature (Temp) is decoded as a 16-bit signed two's complement integer in increments of 1/256°C.
- Received average optical power (Rx Pwr) is decoded as a 16-bit unsigned integer in increments of 0.1 μW.
- Supply voltage (Vcc) is decoded as a 16-bit unsigned integer in increments of 100 μV.
- Bytes 56–94 are not intended for use, but have been set to default values per SFF-8472.
- Tx bias current (Tx Bias) is decoded as a 16-bit unsigned integer in increments of 2 μA.
- Byte 95 is a checksum calculated (per SFF-8472) and stored prior to product shipment.
- Transmitted average optical power (Tx Pwr) is decoded as a 16-bit unsigned integer in increments of 0.1 μW.

**Table 14: EEPROM Serial ID Memory Contents – Soft Commands (Address A2h, Byte 110)**

Bit Number	Status/Control Name	Description	Notes
7	TX_DISABLE State	Digital state of TX_DISABLE Input Pin (1 = TX_DISABLE asserted)	a
6	Soft TX_DISABLE Control	Read/write bit for changing digital state of TX_DISABLE function	a, b
5	RS(1) State	Digital state of TX Rate_Select Input Pin RS(1) (1 = Rate High asserted)	
4	RS(0) State	Digital state of RX Rate_Select Input Pin RS(0) (1 = Rate High asserted)	
3	Soft RS(0) Control	Read/write bit for changing digital state of Rx Rate_Select RS(0) function	c
2	TX_FAULT State	Digital state of TX_FAULT Output Pin (1 = TX_FAULT asserted)	a
1	RX_LOS State	Digital state of SFP RX_LOS Output Pin (1 = RX_LOS asserted)	a
0	Data Ready (Bar)	Indicates transceiver is powered and real time sense data is ready (0 = Data Ready)	

- The response time for soft commands of the AFBR-57G5MZ is 100msec as specified by MSA SFF-8472.
- Bit 6 is log ORed with the SFP TX\_DISABLE input pin 3 .... either asserted will disable the SFP transmitter.
- Bit 3 is log ORed with the SFP RS(0) RX Rate\_Select input pin 7 .... either asserted will set receiver to Rate = High.

**Table 15: EEPROM Serial ID Memory Contents – Soft Commands (Address A2h, Byte 111)**

Bit Number	Status/Control Name	Description	Notes
3–7	Reserved		
2	OWRAP Control Bit	Logic Low = OWRAP disabled. Logic High = OWRAP enabled. When enabled, OWRAP routes incoming SFP Rx optical data to the Tx optical output and Rx electrical output. Enabling clears all other bits in byte 111.	
1	EWRAP FORWARD Control Bit	Logic Low = FORWARD disabled. Logic High = FORWARD enabled. When used in combination with EWRAP enable, FORWARD routes incoming SFP Tx electrical data to both Rx electrical output and Tx optical output. Enabling sets bit 0 and clears all other bits in byte 111.	
0	EWRAP Control Bit	Logic Low = EWRAP disabled. Logic High = EWRAP enabled. When enabled, EWRAP routes incoming SFP Tx electrical data to the Rx electrical output. Enabling clears all other bits in byte 111.	

**Table 16: EEPROM Serial ID Memory Contents – Alarms and Warnings (Address A2h, Bytes 112, 113, 116, 117)**

Byte	Bit	Flag Bit Name	Description
112	7	Temp High Alarm	Set when transceiver internal temperature exceeds high alarm threshold.
	6	Temp Low Alarm	Set when transceiver internal temperature exceeds low alarm threshold.
	5	Vcc High Alarm	Set when transceiver internal supply voltage exceeds high alarm threshold.
	4	Vcc Low Alarm	Set when transceiver internal supply voltage exceeds low alarm threshold.
	3	Tx Bias High Alarm	Set when transceiver laser bias current exceeds high alarm threshold.
	2	Tx Bias Low Alarm	Set when transceiver laser bias current exceeds low alarm threshold.
	1	Tx Power High Alarm	Set when transmitted average optical power exceeds high alarm threshold.
	0	Tx Power Low Alarm	Set when transmitted average optical power exceeds low alarm threshold.
113	7	Rx Power High Alarm	Set when received average optical power exceeds high alarm threshold.
	6	Rx Power Low Alarm	Set when received average optical power exceeds low alarm threshold.
	0–5	Reserved	
116	7	Temp High Warning	Set when transceiver internal temperature exceeds high warning threshold.
	6	Temp Low Warning	Set when transceiver internal temperature exceeds low warning threshold.
	5	Vcc High Warning	Set when transceiver internal supply voltage exceeds high warning threshold.
	4	Vcc Low Warning	Set when transceiver internal supply voltage exceeds low warning threshold.
	3	Tx Bias High Warning	Set when transceiver laser bias current exceeds high warning threshold.
	2	Tx Bias Low Warning	Set when transceiver laser bias current exceeds low warning threshold.
	1	Tx Power High Warning	Set when transmitted average optical power exceeds high warning threshold.
	0	Tx Power Low Warning	Set when transmitted average optical power exceeds low warning threshold.
117	7	Rx Power High Warning	Set when received average optical power exceeds high warning threshold.
	6	Rx Power Low Warning	Set when received average optical power exceeds low warning threshold.
	0–5	Reserved	

**Table 17: EEPROM Serial ID Memory Contents – Soft Commands (Address A2h, Byte 118)**

Bit Number	Status/Control Name	Description	Notes
4–7	Reserved		
3	Soft RS(1) Control	Read/write bit for changing digital state of Tx Rate_Select RS(1) function.	a
2	Reserved		
1	Power Level State	Always set to zero. Value of zero indicates Power Level 1 operation (1W max.).	
0	Power Level Select	Unused. This device supports power level zero (1W max.) only.	

a. Bit 3 is log ORed with the SFP RS(1) TX Rate\_Select input pin 9 .... either asserted will set transmitter to Rate = High.

**Table 18: EEPROM Serial ID Memory Contents – CDR Loss of Lock (LOL) Status Indicators (Address A2h, Byte 119)**

Bit Number	Status/Control Name	Description	Notes
7–2	Reserved		
1	Tx CDR LOL Flag	A value of 0 indicates the CDR is locked. A value of 1 indicates CDR loss of lock. If the CDR is operationally bypassed (that is, for 8.5-Gb/s operation), a value of 0 is shown.	
0	Rx CDR LOL Flag	A value of 0 indicates the CDR is locked. A value of 1 indicates CDR loss of lock. If the CDR is operationally bypassed (that is, for 8.5-Gb/s operation), a value of 0 is shown.	

**Table 19: EEPROM Serial ID Memory Contents – Transmitter Input Electrical Equalization Control (Address A2h, Byte 114)**

Bit Number	Status/Control Name	Description	Notes
7–4	TX EQ, RS(1)=HIGH	Selects an input equalization value per Table 9-13 of SFF-8472 for high rate operation.	
3–0	TX EQ, RS(1)=LOW	Selects an input equalization value per Table 9-13 of SFF-8472 for low rate operation.	

From Table 9-13 of SFF-8472.

**Table 20: Transmitter Input Equalization Control Values (Address A2h, Byte 114)**

Code	Transmitter Input Equalization	
	Nominal	Units
11xx	Reserved	
1011	Reserved	
1010	10	dB
1001	9	dB
1000	8	dB
0111	7	dB
0110	6	dB
0101	5	dB
0100	4	dB
0011	3	dB
0010	2	dB
0001	1	dB
0000	0	No Equalization

**Table 21: EEPROM Serial ID Memory Contents – Receiver Output Electrical Emphasis Control (Address A2h, Byte 115)**

Bit Number	Status/Control Name	Description	Notes
7–4	RX EMPH, RS(0)=HIGH	Selects an output emphasis value per Table 9-14 of SFF-8472 for high rate operation.	
3–0	RX EMPH, RS(0)=LOW	Selects an output emphasis value per Table 9-14 of SFF-8472 for low rate operation.	

From Table 9-14 of SFF-8472.

**Table 22: Receiver Output Emphasis Control Values (Address A2h, Byte 115)**

Code	Receiver Output Emphasis At Nominal Output Amplitude	
	Nominal	Units
1xxx	Vendor Specific	
0111	7	dB
0110	6	dB
0101	5	dB
0100	4	dB
0011	3	dB
0010	2	dB
0001	1	dB
0000	0	No Emphasis

Figure 7: Module Drawing

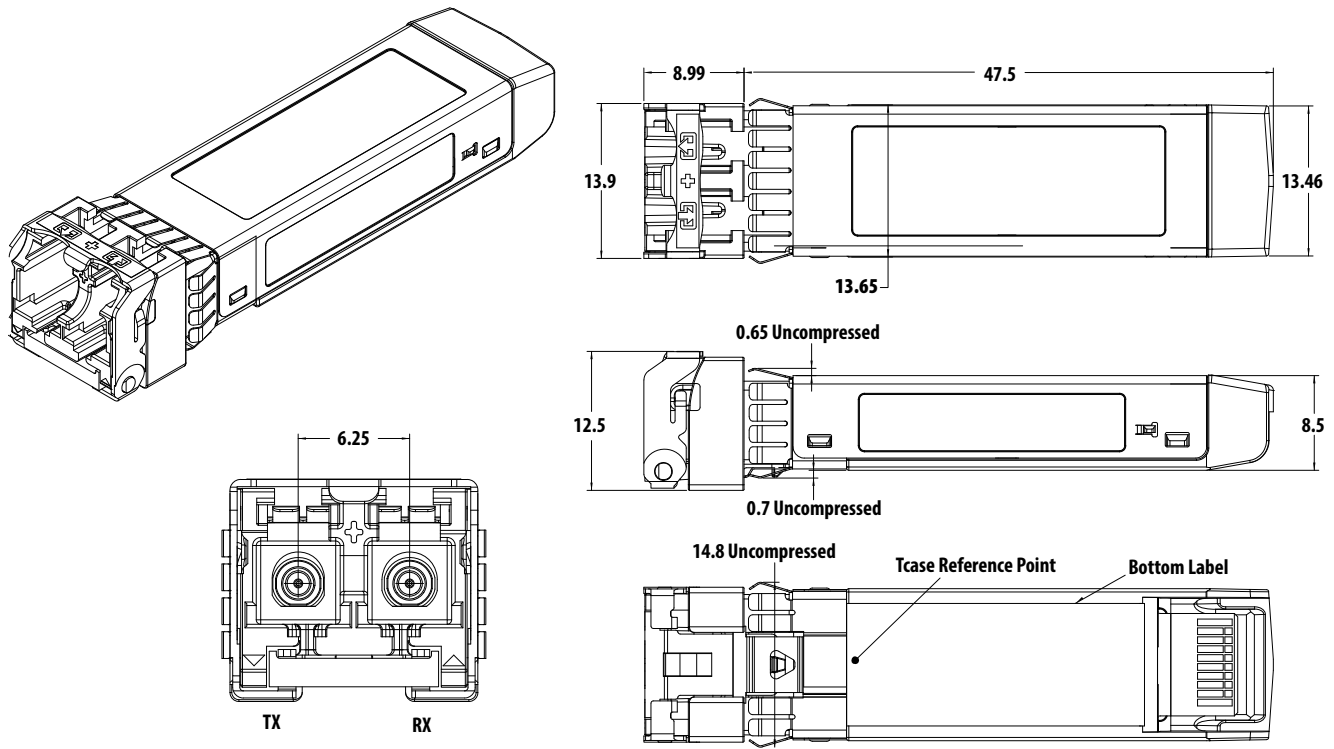

Figure 8: Module Label



Figure 9: SFP Host Board Mechanical Layout

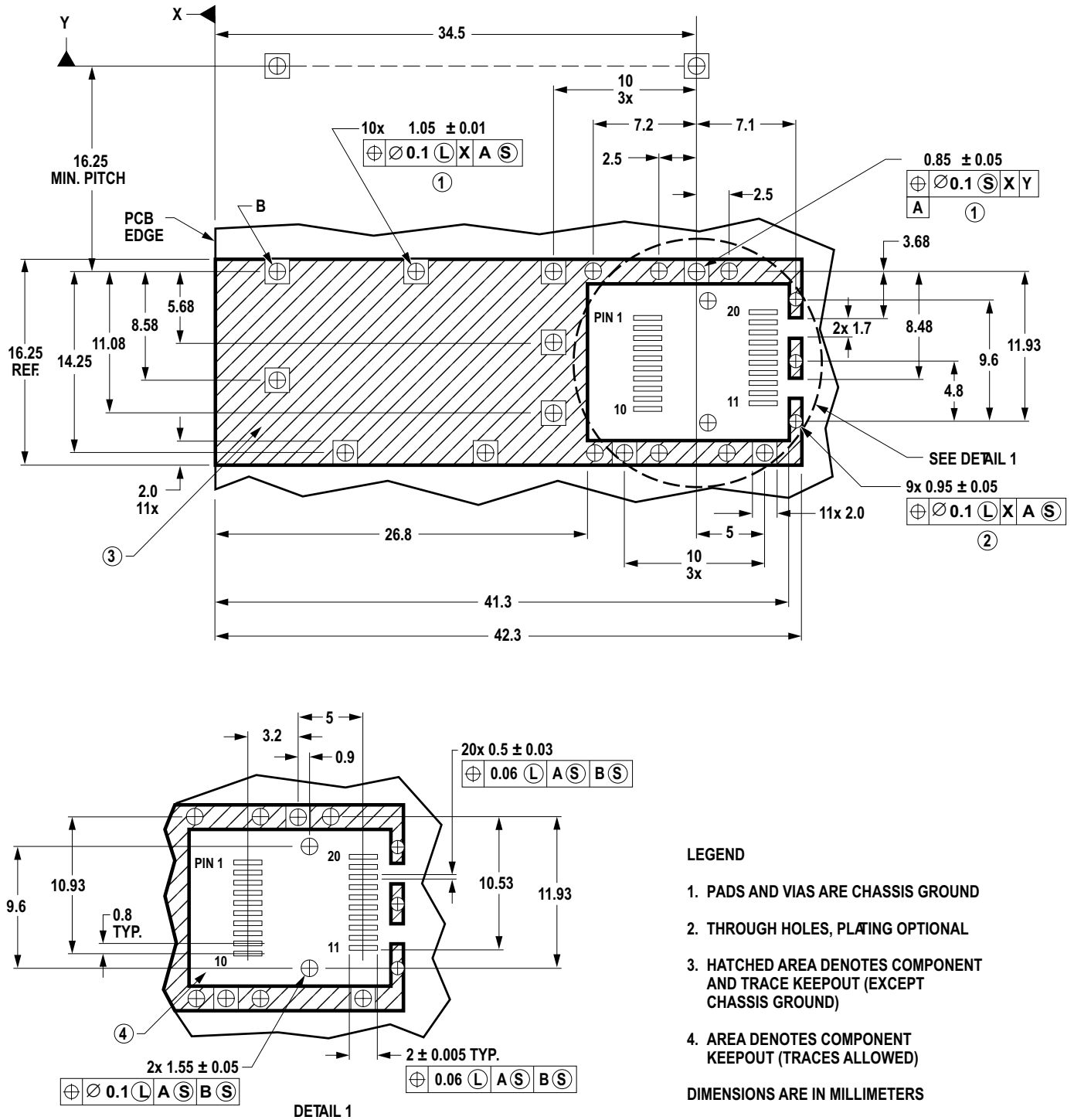
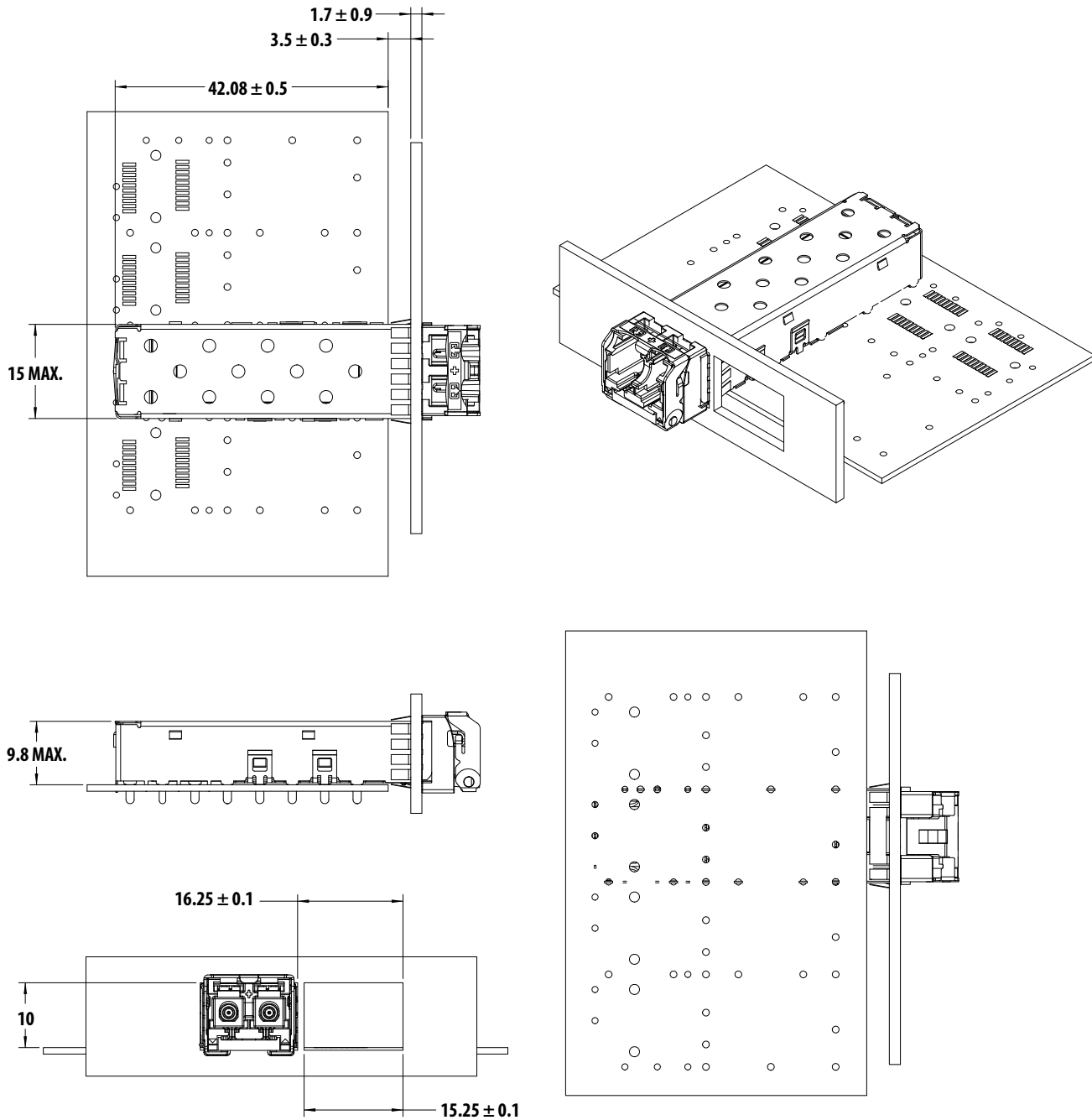

Figure 10: SFP Assembly Drawing



## Customer Manufacturing Processes

This module is pluggable and is not designed for aqueous wash, IR reflow, or wave soldering processes.

Broadcom, the pulse logo, Connecting everything, Avago Technologies, Avago, and the A logo are among the trademarks of Broadcom and/or its affiliates in the United States, certain other countries, and/or the EU.

Copyright © 2015–2021 Broadcom. All Rights Reserved.

The term “Broadcom” refers to Broadcom Inc. and/or its subsidiaries. For more information, please visit [www.broadcom.com](http://www.broadcom.com).

Broadcom reserves the right to make changes without further notice to any products or data herein to improve reliability, function, or design. Information furnished by Broadcom is believed to be accurate and reliable. However, Broadcom does not assume any liability arising out of the application or use of this information, nor the application or use of any product or circuit described herein, neither does it convey any license under its patent rights nor the rights of others.