



Quartz Crystal

SMD-version

part no.	12.60126
model	KX – 7F
frequency	8.0 MHz
mode	fundamental
operating temperature	-40° ~ +125°C
frequency tolerance at +25°C	±50 ppm
temperature tolerance -40° ~ +125°C	±150 ppm
load capacitance C_L	12 pF
series resistance R_1 max.	800 Ohm
aging at +25°C (first year) max.	±2 ppm
shunt capacitance C_0 max.	3.5 pF
drive level max.	200 μ W
contents of reel	1000 pcs.

Dimensions (mm):

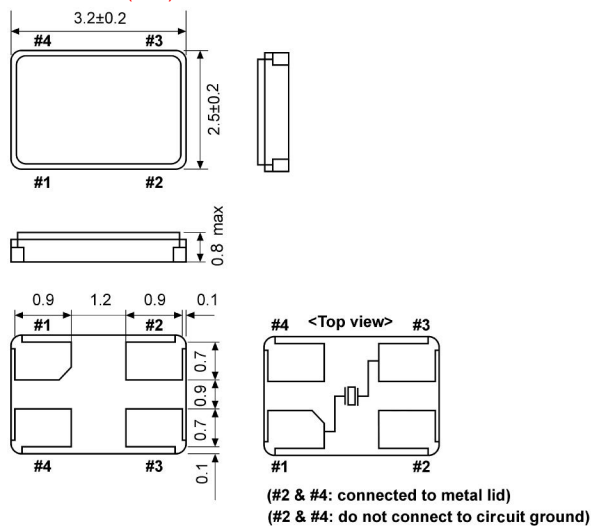

Reflow soldering condition:

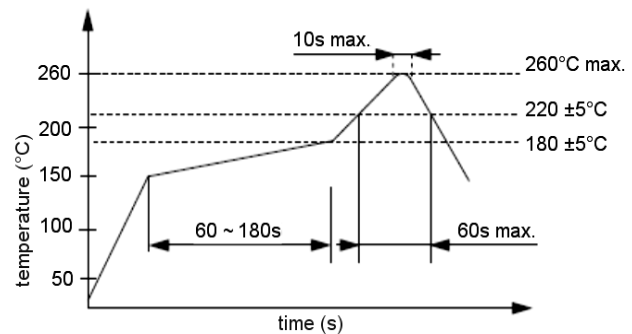

Suggested soldering pad:

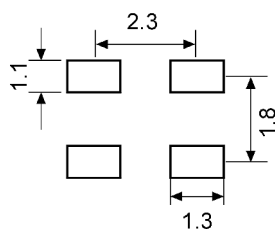

Tape specification:

