

| 未注公差/General tolerances (mm) | | | | | | | | | | | | | 0.1/10 ±2' |
|------------------------------|-------|-------|-------|-------|-------|-------|-------|-------|-------|-------|-------|-------|---------------|
| 0 | >3 | >6 | >10 | >18 | >30 | >50 | >80 | >120 | >180 | >250 | >315 | >400 | |
| ~3 | ~6 | ~10 | ~18 | ~30 | ~50 | ~80 | ~120 | ~180 | ~250 | ~315 | ~400 | ~500 | >500 |
| ±0.12 | ±0.18 | ±0.22 | ±0.26 | ±0.31 | ±0.37 | ±0.57 | ±0.80 | ±0.93 | ±1.05 | ±1.15 | ±1.60 | ±2.20 | ±2.50 |

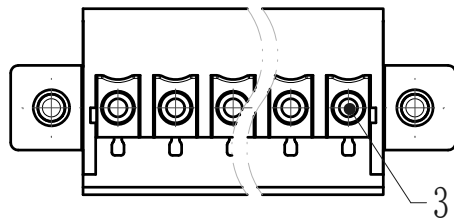

02P-06P have the salient,
07P-24P have not the salient

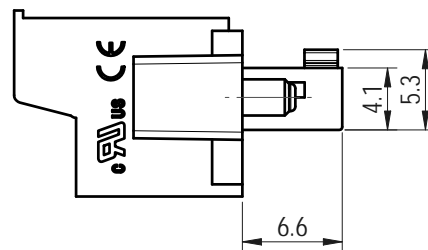
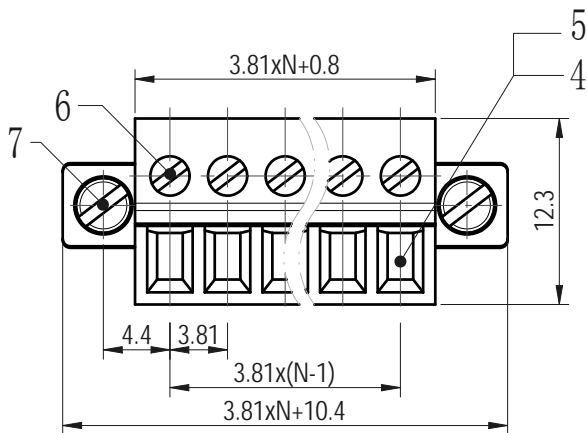
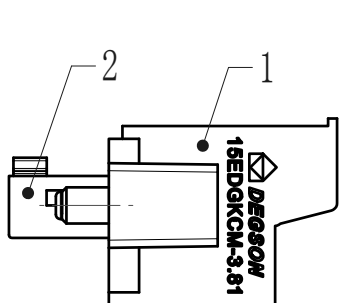
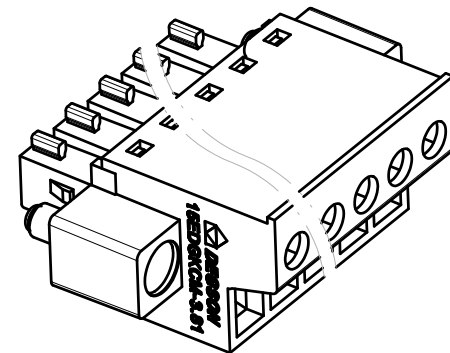
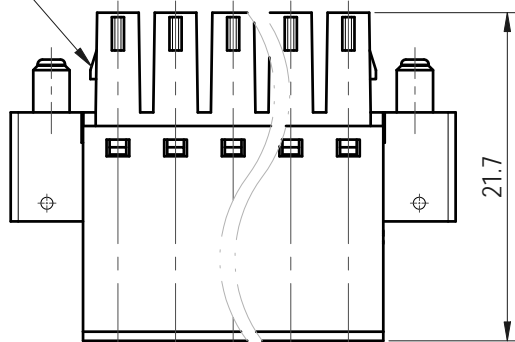

| ITEM | NAME OF PART | MATERIAL | NOTES |
|------|--------------|--------------|----------------|
| 7 | Screw2 | Steel | M2.5/Zn Plated |
| 6 | Screw1 | Steel | M2/Zn Plated |
| 5 | Cage | Steel | M2/Zn Plated |
| 4 | Block | Steel | Zn Plated |
| 3 | Clamp | Copper alloy | Sn Plated |
| 2 | Cover | PA66 | UL94V-0 |
| 1 | Housing | PA66 | UL94V-0 |

| UL 标准/UL Standard: | B | C | D |
|---|-----------------|-------|-------|
| 额定电压/电流/Rated Voltage(V)/Current(A) | 300/8 | / | 300/8 |
| IEC 标准/IEC Standard: | | | |
| 过压类别/Ovenvoltage Category/污染等级/Pollution Degree | III/3 | III/2 | II/2 |
| 额定电压/电流/Rated Voltage(V)/Current(A) | / | 250/8 | / |
| 额定脉冲电压(KV)/Rate Impulse Voltage(KV) | / | 2.5 | / |
| 螺丝扭矩/Torque Tightening(N·m/Lb.in) | M2, 0.2/1.77 | | |
| 线径范围(硬线和软线)/Wire Range(rigid and flexible)(AWG/mm²) | 30~16 / 0.2~1.5 | | |
| 间距/Pitch(mm)/线数范围/Poles | 3.81/N=02~24P | | |
| 剥线长度/Stripping length(mm) | 8~9 | | |
| 使用温度范围/Operating temperature(°C) | -40~+105 | | |
| 符合RoHS环保要求/Conform to RoHS | Yes | | |

| | | | | |
|----------------------|------------------|-----------------------------|----------------|-------|
| | | MATERIAL: | SURFACE/COLOR: | |
| APPD: 兰春华 2023.02.23 | | MAT NO./REV: | / 00 | |
| CHKD: 龚耀志 2023.02.22 | | NAME | | |
| DRFT: 朱岳鹏 2023.02.22 | | 15EDGKCM-3.81-XXP-1Y-00L(H) | | |
| DRAWING NO. | TYPE | DRAWING STATUS | SCALE | SHEET |
| 200020028 | CUSTOMER DRAWING | 已发布 | 2:1 | 1/1 |

| REV | ECN | DESCRIPTION | DRFT | DATE |
|-----|-----|-------------|------|------------|
| 00 | | | 朱岳鹏 | 2023.02.22 |

Transfer or duplication of this document as well as the utilization or communication of its content are prohibited unless authorized in writing by DEGSON. All rights reserved for patent. 除专利号明确标注外，其他内容均受版权保护。未经授权，不得复制或传播。 未经授权，不得复制或传播。 未经授权，不得复制或传播。