

PRODUCT DATA DRAWING

REVISION HISTORY			
REV	DESCRIPTION	DATE	APPROVED
-	NRN 42358	05/18	STW
A	DCN 47550	06/18	JDT

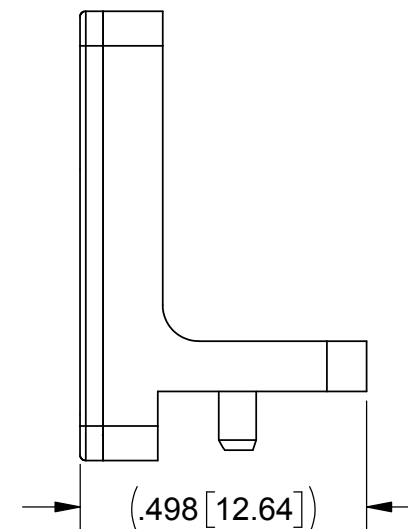
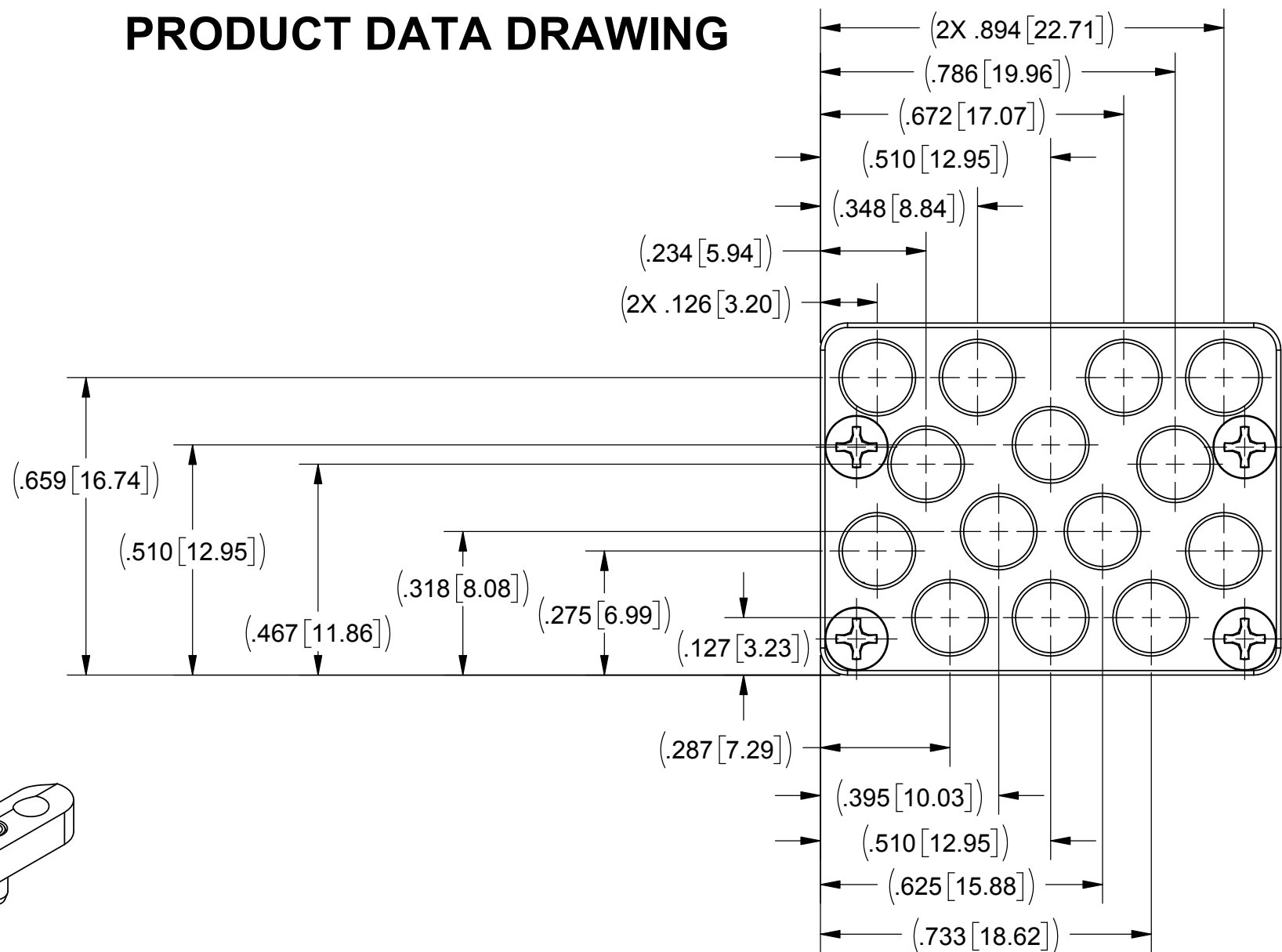
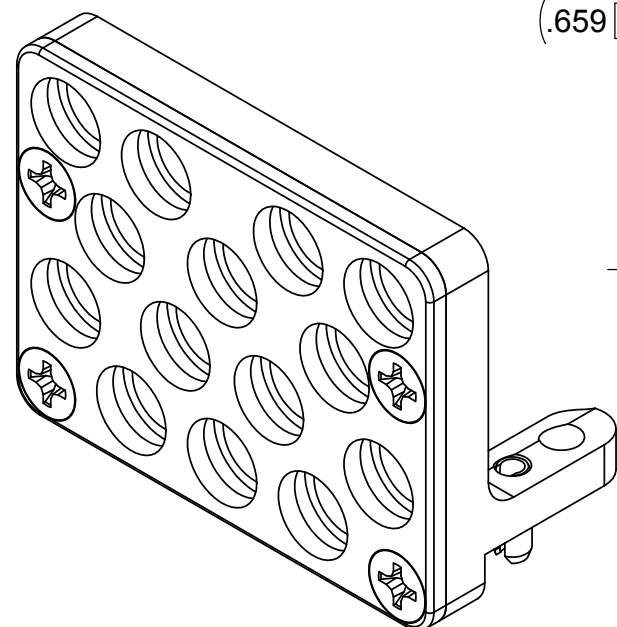

MATERIAL:

BODIES: STAINLESS STEEL PER AMS-5640, ALLOY UNS S30300, TYPE 1; OR ASTM A582 TYPE 303, COND. A

CONTACT: BERYLLIUM COPPER PER ASTM B196, ALLOY No. UNS C17300, TD04

INSULATOR: PTFE PER ASTM D1710, TYPE I, GRADE 1, CLASS B

SPRING PIN: 420 STAINLESS STEEL

FINISH:

BODIES: PASSIVATED PER AMS-2700

CONTACT: GOLD PER ASTM B488, TYPE II, CODE C, CLASS 1.27, OVER NICKEL PER AMS-QQ-N-290, CLASS 1, .00005" MIN.

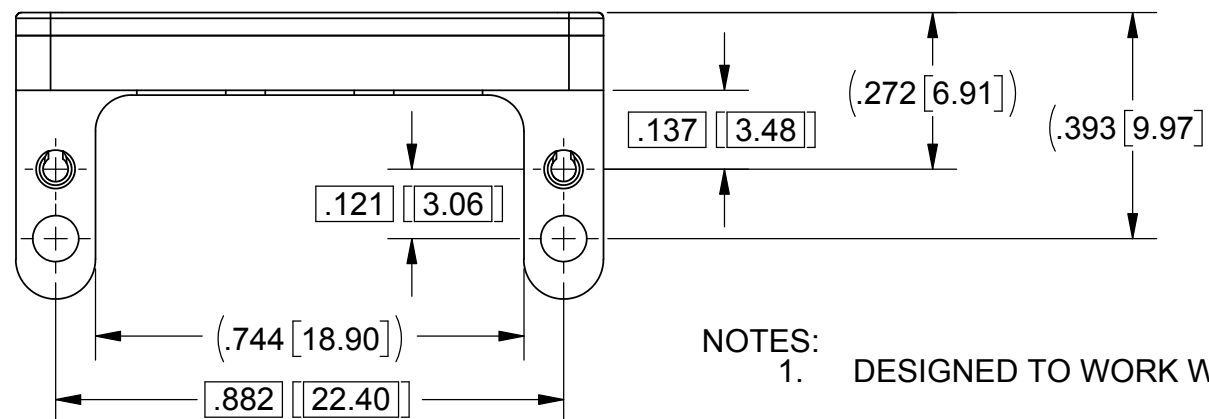

NOTES:
1. DESIGNED TO WORK WITH SF9321-60086.

MATERIAL: SEE NOTES	DIMENSIONS ARE IN INCHES TOLERANCES: FRACTIONAL: ±1/64 ANGULAR: X° ±1'0" X'X' ±15'	UNLESS OTHERWISE SPECIFIED 1) ALL DIMENSIONS ARE IN INCHES (MILLIMETERS) 2) ALL DIMENSIONS ARE AFTER PLATING. 3) BREAK CORNERS & EDGES .005 R. MAX. 4) CHAM. 1ST & LAST THREADS. 5) SURFACE ROUGHNESS 63-MIL-STD-10. 6) DIA: 'S ON COMMON CENTERS TO BE CONCENTRIC WITHIN .005 T.I.R. 7) REMOVE ALL BURRS	 2400 Centrepark West Drive, Suite 100 West Palm Beach, FL 33409 TITLE: VITA 67.3 PLUG-IN MODULE C 14 PORT, SMPM
FINISH: SEE NOTES	DECIMAL: X ±.030 .XX ±.010 .XXX ±.005	INTERPRET DIMENSIONS AND TOLERANCES PER ASME Y14.5M - 1994	
SURFACE AREA: N/A	THIRD ANGLE PROJECTION	DRAWN: VB 04/19/18	SIZE: B CAGE CODE: 95077 DWG. NO.: SF9311-60147
<p>PROPRIETARY</p> <p>THE INFORMATION CONTAINED IN THIS DRAWING IS THE SOLE PROPERTY OF SV MICROWAVE, INC. ANY REPRODUCTION IN PART OR AS A WHOLE WITHOUT THE WRITTEN PERMISSION OF SV MICROWAVE, INC IS PROHIBITED.</p>		CHECKED: JDT 04/19/18	SCALE: 4:1
		APPROVED: JDT 04/19/18	SHEET 1 OF 2

CUI BASIC PRODUCT DATA DRAWING

REVISION HISTORY			
REV	DESCRIPTION	DATE	APPROVED
	SEE SHEET 1		

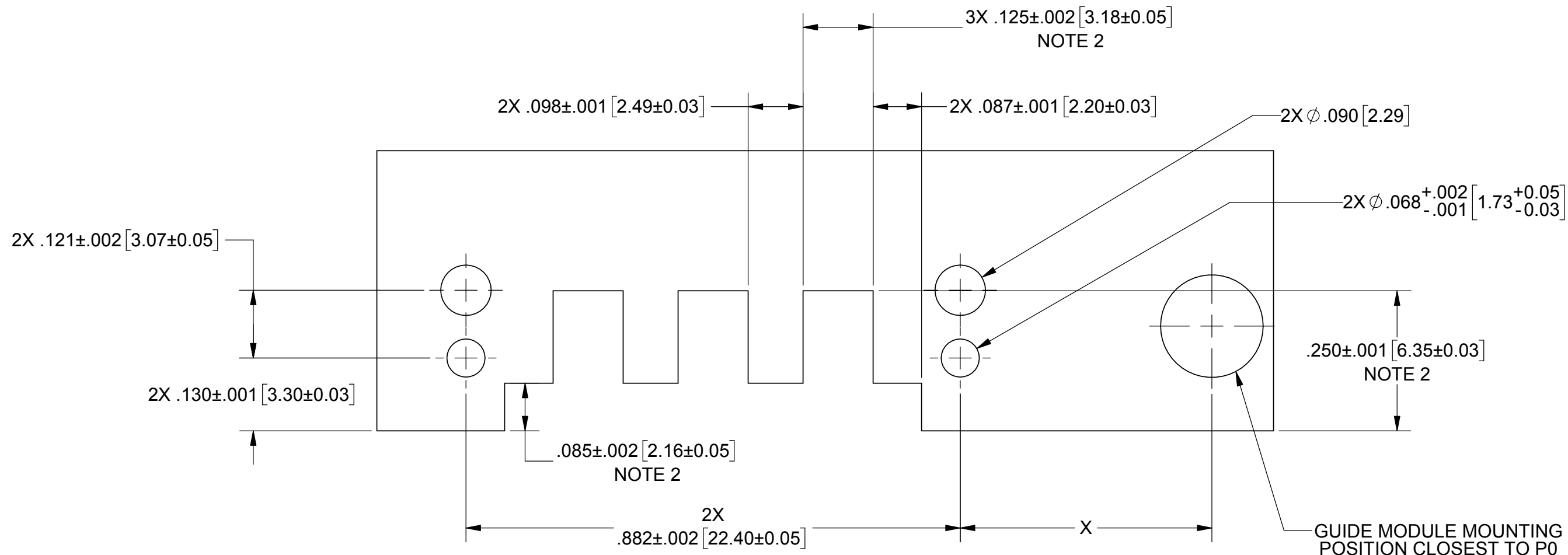

RECOMMENDED PCB CUTOUT

CONNECTOR LOCATION ON DAUGHTER CARD PCB	
POSITION	DIM 'X'
P2	2.144" [54.46]
P3	3.701" [94.01]
P4	5.035" [127.89]
P5	6.168" [156.67]
P6	7.316" [185.83]

NOTES:
2. DIMENSIONS WHEN USING 3211-60035 EDGE LAUNCH CONNECTOR.

MATERIAL:	SEE NOTES	DIMENSIONS ARE IN INCHES TOLERANCES: FRACTIONAL: ±1/64 ANGULAR: X° ±1'0" X°X' ±15'	UNLESS OTHERWISE SPECIFIED 1) ALL DIMENSIONS ARE IN INCHES (MILLIMETERS) 2) ALL DIMENSIONS ARE AFTER PLATING. 3) BREAK CORNERS & EDGES .005 R. MAX. 4) CHAM. 1ST & LAST THREADS. 5) SURFACE ROUGHNESS 63-MIL-STD-10. 6) DIA. 'S' ON COMMON CENTERS TO BE CONCENTRIC WITHIN .004 T.I.R. 7) REMOVE ALL BURRS	Amphenol SV MICROWAVE 2400 Centrepark West Drive, Suite 100 West Palm Beach, FL 33409
FINISH:	SEE NOTES	DECIMAL: X ±.030 .XX ±.010 .XXX ±.005	INTERPRET DIMENSIONS AND TOLERANCES PER ASME Y14.5M - 1994	TITLE: VITA 67.3 PLUG-IN MODULE C, 14 PORT, SMPM
SURFACE AREA:	N/A	THIRD ANGLE PROJECTION	DRAWN: VB 04/19/18 CHECKED: JDT 04/19/18 APPROVED: JDT 04/19/18	SIZE: B CAGE CODE: 95077 DWG. NO.: SF9311-60147
PROPRIETARY THE INFORMATION CONTAINED IN THIS DRAWING IS THE SOLE PROPERTY OF SV MICROWAVE, INC. ANY REPRODUCTION IN PART OR AS A WHOLE WITHOUT THE WRITTEN PERMISSION OF SV MICROWAVE, INC IS PROHIBITED.				SCALE: 5:1 SHEET 2 OF 2