

DO NOT SCALE FROM THIS PRINT

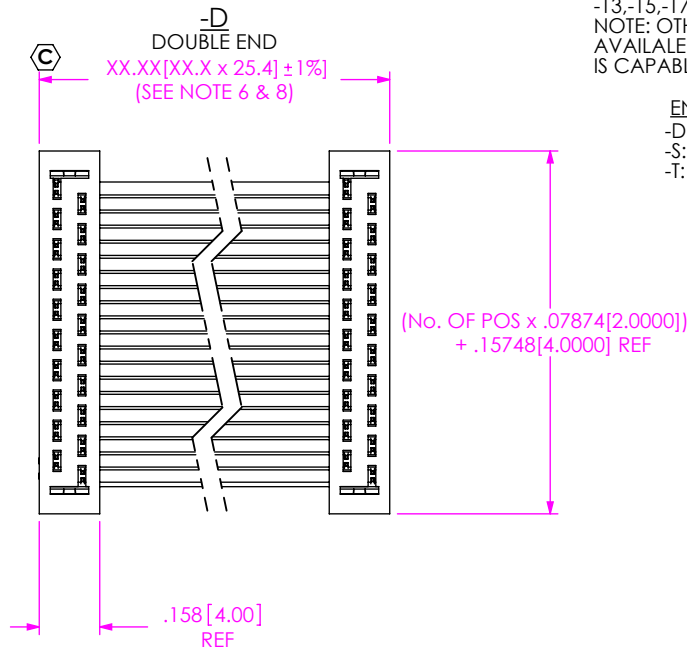

No OF POSITIONS
 -03,-04,-05,-08,-10,-12,
 -13,-15,-17,-20,-22,-25
 NOTE: OTHER POSITIONS
 AVAILALE AS ASO. TOOL
 IS CAPABLE OF POSITIONS 2-25

END ASSEMBLY
 -D: DOUBLE END
 -S: SINGLE END
 -T: TRANSFER END

ASSEMBLY LENGTH
 (2 INCH MINIMUM)

LEAD STYLE

OPTION
 SEE SHEETS 2, 3 & 4

OPTION
 SEE SHEETS 2, 3 & 4

OPTION
 LEAVE BLANK FOR TIN PLATING
 (FOR -S & -D USE TCMD-XX-01)
 (FOR TRANSFER OPTION USE TCMD-XX-01 AND TCSD-XX-01)
 -F: FLASH GOLD PLATING
 (FOR TRANSFER OPTION ONLY)
 (USE TCMD-XX-01 AND TCSD-XX-01-F)
 -RF: FLASH GOLD PLATING
 (FOR DOUBLE AND SINGLE ENDED USE TCMD-XX-01-RF)
 (FOR TRANSFER OPTION USE TCMD-XX-01-RF AND TCSD-XX-01-F)

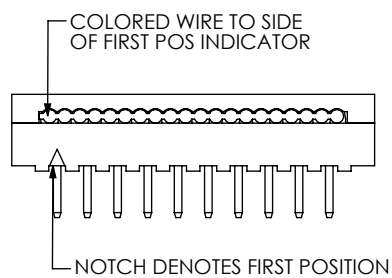
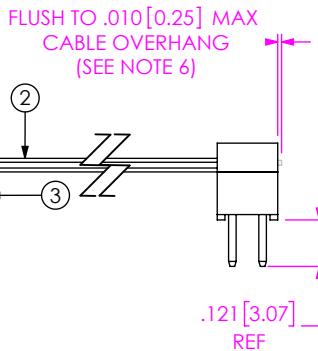
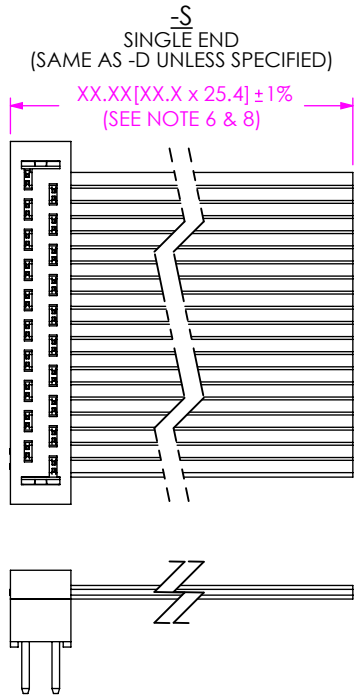

- NOTES:
- ⊕ REPRESENTS A CRITICAL DIMENSION.
 - AS OF REV C ON TCB-50 CABLE, ASSEMBLIES WILL BE LEAD FREE.
 - ALL ASSEMBLIES TO BE 100 % ELECTRONICALLY TESTED FOR SHORTS AND OPENS.
 - ALL ASSEMBLIES TO BE 100 % HI-POT TESTED AT 800V.
 - STRAIN RELIEF TO WITHSTAND 5LBS STRAIGHT PULL.
 - WHEN CUTTING CABLE TO LENGTH, CONDUCTORS SHOULD NOT EXTEND PAST THE CABLE INSULATION, EXTENDING LESS THAN 25% OF CABLE THICKNESS ON CONSECUTIVE AND LESS THAN 50% OF CABLE THICKNESS ON NON-CONSECUTIVE STRANDS IS CONSIDERED A PROCESS INDICATOR.
 - SEE TCMD-XX-XX-XX-XX (AND TCSD-XX-XX-X-XXX FOR -T END ASSEMBLY OPTION) PRINT FOR CONNECTOR ASSEMBLY INSTRUCTIONS AND ITS REQUIREMENTS.
 - FOR LENGTHS LESS THAN 12.5", TOLERANCE SHALL BE +/- .125, ALL OTHER LENGTHS SHALL BE +/- 1%.

TABLE 1

ITEM #	PART
1	TCSD-XX-01-XXX
2	TCB-50
3	TCMD-XX-01
4	TCMD-XX-01-SR
5	TMSR-XX
6	TTC-XX-D
7	T-1S14-XX-X

UNLESS OTHERWISE SPECIFIED, DIMENSIONS ARE IN INCHES.
 TOLERANCES ARE:
 DECIMALS ANGLES
 .XX: ±.01 [.3] 2°
 .XXX: ±.005 [.13]
 .XXXX: ±.0020 [.051]

PROPRIETARY NOTE
 * THIS DOCUMENT CONTAINS CONFIDENTIAL AND PROPRIETARY INFORMATION AND ALL DESIGN, MANUFACTURING, REPRODUCTION, USE, PATENT RIGHTS AND SALES RIGHTS ARE EXPRESSLY RESERVED BY SAMTEC, INC. THIS DOCUMENT SHALL NOT BE DISCLOSED, IN WHOLE OR PART, TO ANY UNAUTHORIZED PERSON OR ENTITY NOR REPRODUCED, TRANSFERRED OR INCORPORATED IN ANY OTHER PROJECT IN ANY MANNER WITHOUT THE EXPRESS WRITTEN CONSENT OF SAMTEC, INC.

MATERIAL: DO NOT SCALE DRAWING SHEET SCALE: 2:1
 INSULATOR: VALOX 420 SEO, COLOR: BLACK
 CONTACT: #25 BeCu 1/2 HARD, AGE HARDENED
 TERMINAL: SPRING TEMPER PHOS BRONZE, ALLOY 510
 STRAIN RELIEF: CELANEX 3300, COLOR: BLACK
 WIRE: 28 AWG, 7/36, TINNED Cu, STRANDED WITH PVC
 INSULATOR

520 PARK EAST BLVD, NEW ALBANY, IN 47150
 PHONE: 812-944-6733 FAX: 812-948-5047
 e-Mail: info@SAMTEC.com code: 5332

DESCRIPTION:
 2MM DOUBLE ROW MALE IDC CABLE ASSEMBLY
 DWG. NO.
 TCMD-XX-X-XX.XX-01-XX-XXX-XXX
 BY: B RAY 11/26/2007 SHEET 1 OF 5

-SR:
 STRAIN RELIEF
 (NOT AVAILABLE WITH -O, -M, -R, -DXX, OR -BXX)
 (SOLD AS ASSEMBLIES ONLY)
 (SAME AS -D UNLESS SPECIFIED)
 (MUST USE HEAT BEND/STRAIN RELIEF TOOL ON POSITIONS 20-25)

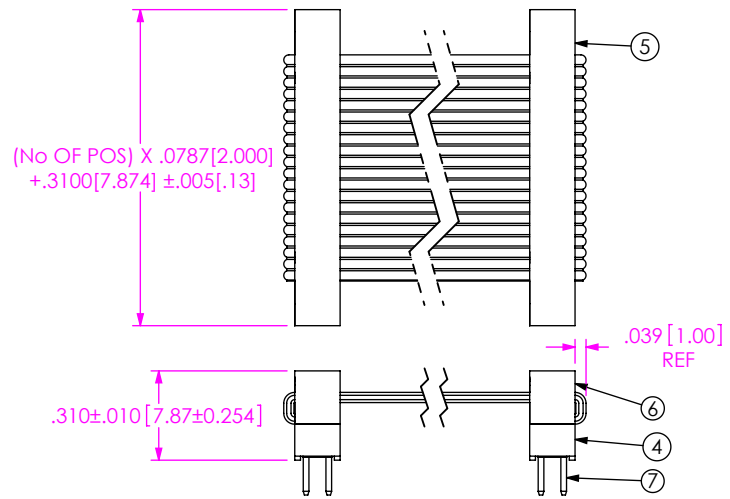

IN-PROCESS 1
 -SR ONLY

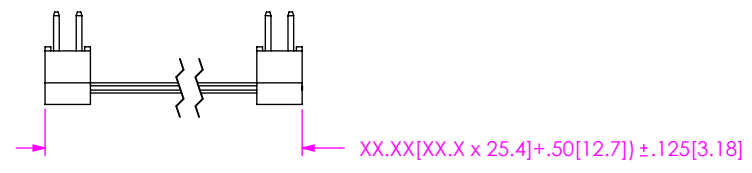

IN-PROCESS 2
 -SR ONLY

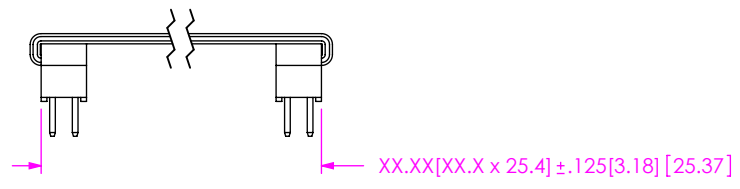

-N
 NOTCH POLARIZATION
 (FOR -T ONLY)
 (IF OPTION IS SPECIFIED USE TCSD-XX-01-N)

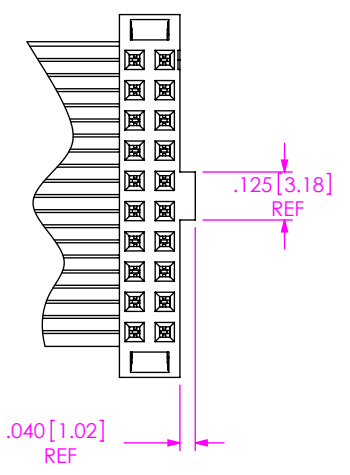

-RW
 REVERSE WIRING

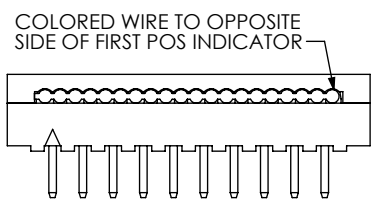

-BXX
 BREAKOUT OPTION
 "XX" = NO OF CONDUCTORS PER ROW
 BROKEN OUT FROM THE FIRST POSITION

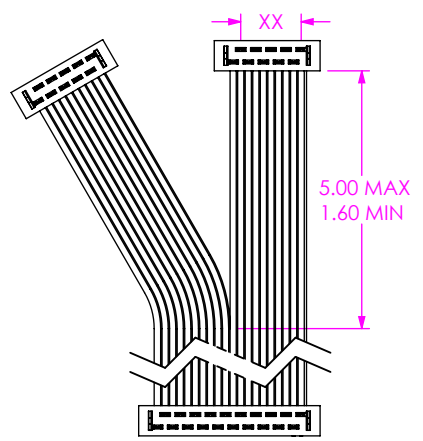

-S-BXX-RW
 SINGLE END & BREAKOUT & REVERSE WIRING OPTION
 "XX" = NO OF CONDUCTORS
 BROKEN OUT FROM THE FIRST POSITION

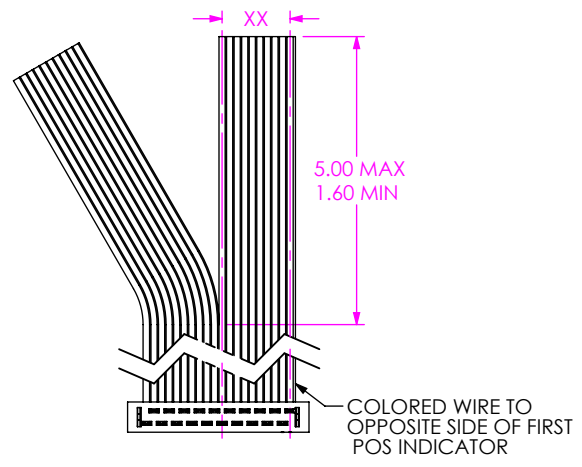

-T
 TRANSFER END
 (SAME AS -D UNLESS SPECIFIED)

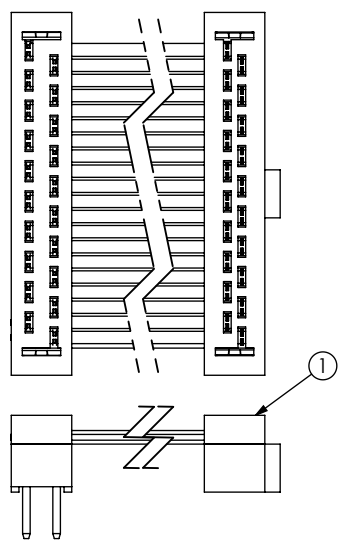

-P"XX"
 POLARIZED MATING
 (USE PK-07-N POLARIZING KEY)
 (REQUIRES TRANSFER END. ONLY SOCKET IS POLARIZED)

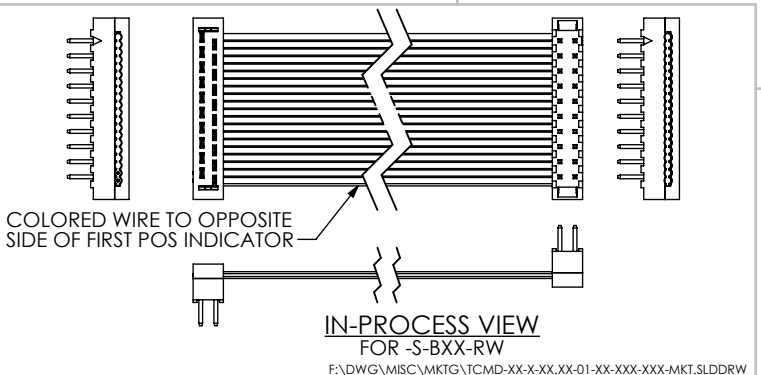
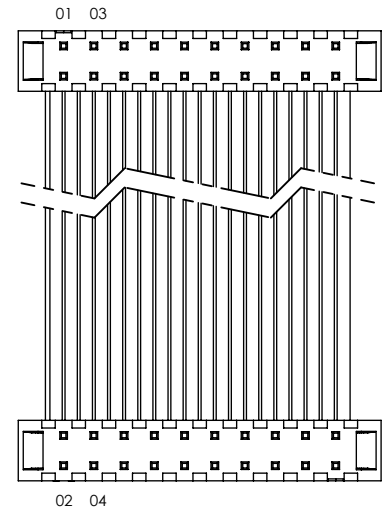

PROPRIETARY NOTE
 THIS DOCUMENT CONTAINS CONFIDENTIAL AND PROPRIETARY INFORMATION AND ALL DESIGN, MANUFACTURING, REPRODUCTION, USE, PATENT RIGHTS AND SALES RIGHTS ARE EXPRESSLY RESERVED BY SAMTEC, INC. THIS DOCUMENT SHALL NOT BE DISCLOSED, IN WHOLE OR PART, TO ANY UNAUTHORIZED PERSON OR ENTITY NOR REPRODUCED, TRANSFERRED OR INCORPORATED IN ANY OTHER PROJECT IN ANY MANNER WITHOUT THE EXPRESS WRITTEN CONSENT OF SAMTEC, INC.

DO NOT SCALE DRAWING
 SHEET SCALE: 1.5:1



520 PARK EAST BLVD, NEW ALBANY, IN 47150
 PHONE: 812-944-6733 FAX: 812-948-5047
 e-Mail: info@SAMTEC.com code: 55322

DESCRIPTION:
 2MM DOUBLE ROW MALE IDC CABLE ASSEMBLY
 DWG. NO.
TCMD-XX-X-XX.XX-01-XX-XXX-XXX
 BY: B RAY 11/26/2007 SHEET 2 OF 5

-O
OUTSIDE REVERSED
 (NOT AVAILABLE WITH -R OR -M OPTIONS)

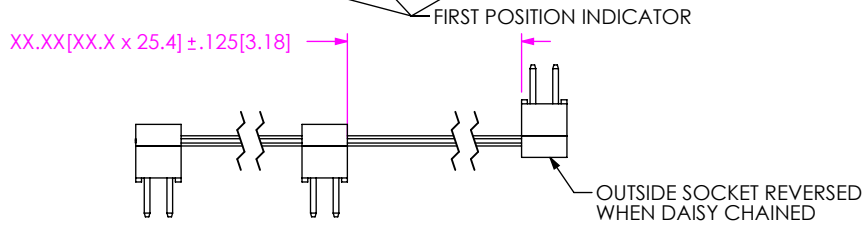
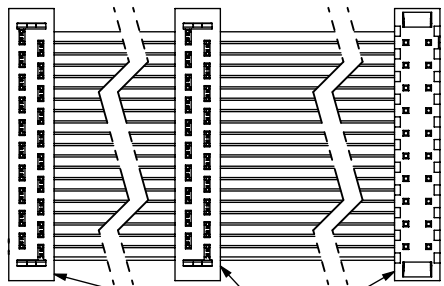

-M
MIDDLE REVERSED
 (NOT AVAILABLE WITH -R OR -O OPTIONS)

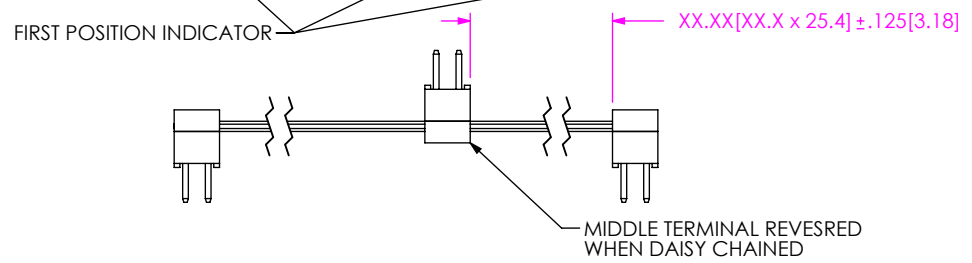
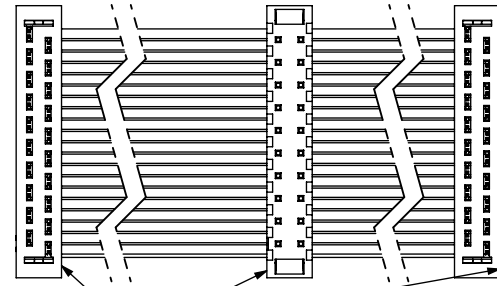

-O
OUTSIDE TRANSFER
 (NOT AVAILABLE WITH -R OR -M OPTIONS)

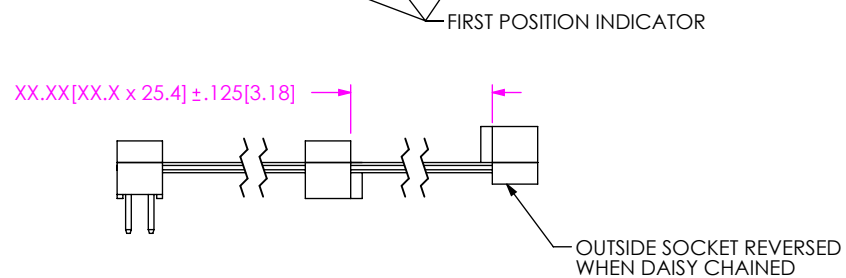
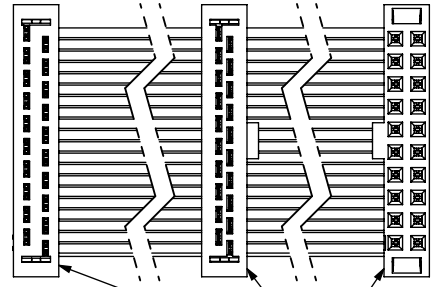

-M
MIDDLE TRANSFER
 (NOT AVAILABLE WITH -R OR -O OPTIONS)

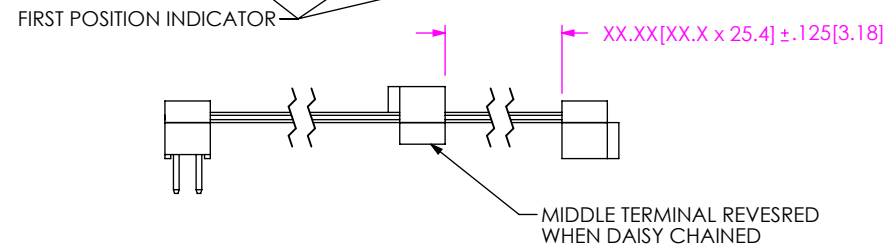
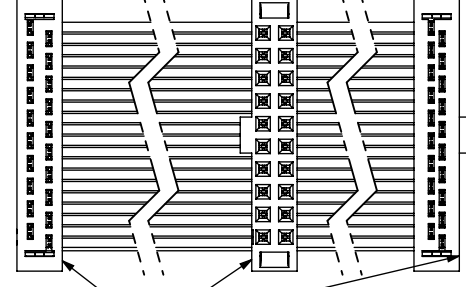

PROPRIETARY NOTE
 THIS DOCUMENT CONTAINS CONFIDENTIAL AND PROPRIETARY INFORMATION AND ALL DESIGN, MANUFACTURING, REPRODUCTION, USE, PATENT RIGHTS AND SALES RIGHTS ARE EXPRESSLY RESERVED BY SAMTEC, INC. THIS DOCUMENT SHALL NOT BE DISCLOSED, IN WHOLE OR PART, TO ANY UNAUTHORIZED PERSON OR ENTITY NOR REPRODUCED, TRANSFERRED OR INCORPORATED IN ANY OTHER PROJECT IN ANY MANNER WITHOUT THE EXPRESS WRITTEN CONSENT OF SAMTEC, INC.

DO NOT SCALE DRAWING
 SHEET SCALE: 1.5:1



520 PARK EAST BLVD, NEW ALBANY, IN 47150
 PHONE: 812-944-6733 FAX: 812-948-5047
 e-Mail: info@SAMTEC.com code: 55322

DESCRIPTION:
 2MM DOUBLE ROW MALE IDC CABLE ASSEMBLY
 DWG. NO.
 TCMD-XX-X-XX.XX-01-XX-XXX-XXX
 BY: B RAY 11/26/2007 SHEET 3 OF 5

-R
REVERSE CONNECTOR
 (NOT AVAILABLE WITH -M OR -O OPTIONS)

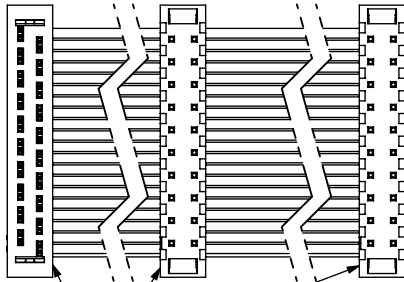

FIRST POSITION INDICATOR

BOTH TERMINAL REVERSED
 WHEN DAISY CHAINED

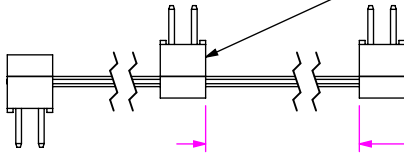

$XX.XX[XX.X \times 25.4] \pm .125[3.18]$

-D"XX"
DAISY CHAIN - DOUBLE

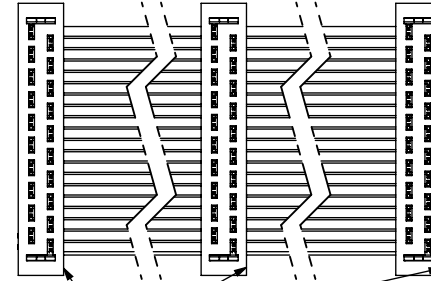

FIRST POSITION INDICATOR

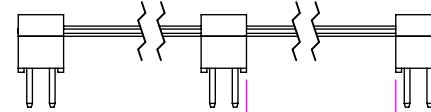

$XX.XX[XX.X \times 25.4] \pm .125[3.18]$

NOTE:
 2" MINIMUM LENGTH
 1" INCREMENTS ONLY

-R
REVERSE TRANSFER
 (NOT AVAILABLE WITH -M OR -O OPTIONS)

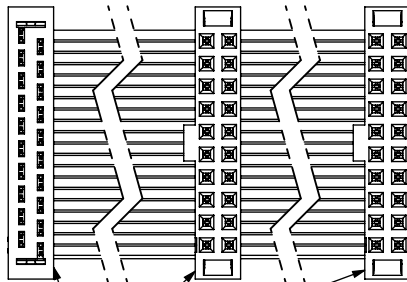

FIRST POSITION INDICATOR

BOTH TERMINAL REVERSED
 WHEN DAISY CHAINED

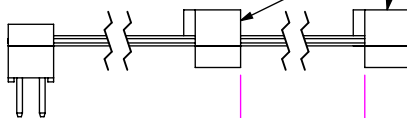

$XX.XX[XX.X \times 25.4] \pm .125[3.18]$

-D"XX"
DAISY CHAIN TRANSFER

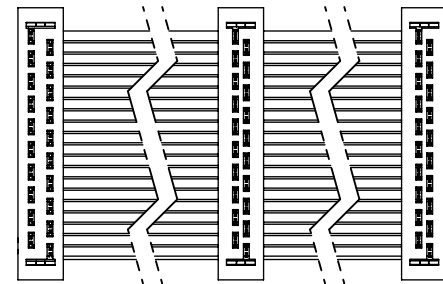

$XX.XX[XX.X \times 25.4] \pm .125[3.18]$

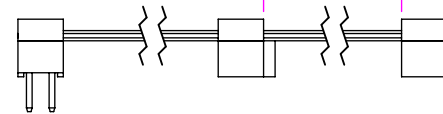

NOTE:
 2" MINIMUM LENGTH
 1" INCREMENTS ONLY

PROPRIETARY NOTE
 * THIS DOCUMENT CONTAINS CONFIDENTIAL AND PROPRIETARY INFORMATION AND ALL DESIGN, MANUFACTURING, REPRODUCTION, USE, PATENT RIGHTS AND SALES RIGHTS ARE EXPRESSLY RESERVED BY SAMTEC, INC. THIS DOCUMENT SHALL NOT BE DISCLOSED, IN WHOLE OR PART, TO ANY UNAUTHORIZED PERSON OR ENTITY NOR REPRODUCED, TRANSFERRED OR INCORPORATED IN ANY OTHER PROJECT IN ANY MANNER WITHOUT THE EXPRESS WRITTEN CONSENT OF SAMTEC, INC.



520 PARK EAST BLVD, NEW ALBANY, IN 47150
 PHONE: 812-944-6733 FAX: 812-948-5047
 e-Mail: info@SAMTEC.com code: 55322

DO NOT SCALE DRAWING

SHEET SCALE: 1.5:1

DESCRIPTION:
 2MM DOUBLE ROW MALE IDC CABLE ASSEMBLY

DWG. NO.
TCMD-XX-X-XX.XX-01-XX-XXX-XXX

BY: B RAY 11/26/2007 SHEET 4 OF 5

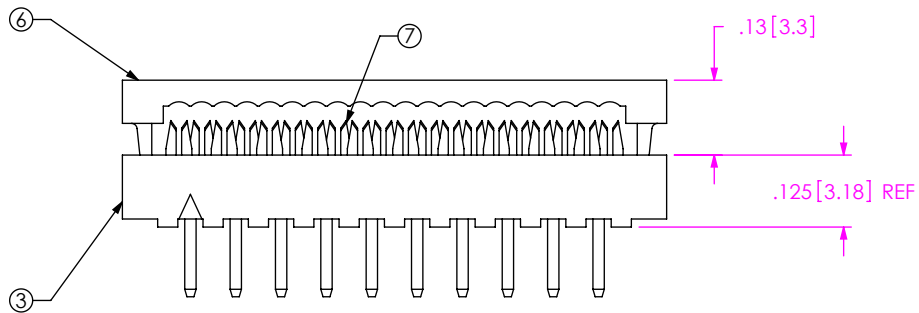

END VIEW SHOWN WITH
TTC-XX-D REMOVED

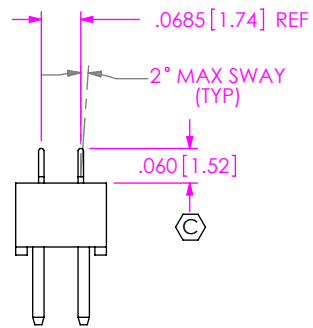

IN-PROCESS VIEW

PROPRIETARY NOTE
 THIS DOCUMENT CONTAINS CONFIDENTIAL AND PROPRIETARY INFORMATION AND ALL DESIGN, MANUFACTURING, REPRODUCTION, USE, PATENT RIGHTS AND SALES RIGHTS ARE EXPRESSLY RESERVED BY SAMTEC, INC. THIS DOCUMENT SHALL NOT BE DISCLOSED, IN WHOLE OR PART, TO ANY UNAUTHORIZED PERSON OR ENTITY NOR REPRODUCED, TRANSFERRED OR INCORPORATED IN ANY OTHER PROJECT IN ANY MANNER WITHOUT THE EXPRESS WRITTEN CONSENT OF SAMTEC, INC.

DO NOT SCALE DRAWING

SHEET SCALE: 1.5:1



520 PARK EAST BLVD, NEW ALBANY, IN 47150
 PHONE: 812-944-6733 FAX: 812-948-5047
 e-Mail: info@SAMTEC.com code: 55322

DESCRIPTION:
 2MM DOUBLE ROW MALE IDC CABLE ASSEMBLY

DWG. NO.
 TCMD-XX-X-XX.XX-01-XX-XXX-XXX

BY: B RAY 11/26/2007 SHEET 5 OF 5