

DO NOT SCALE FROM THIS PRINT

DESIGNED & DIMENSIONED IN MILLIMETERS [INCHES]

MCX7-P-C-XX-ST-CA3-X

GENDER
-P: PLUG

TYPE
-C: CABLE

PACKAGING
-BLANK: INDIVIDUALLY BAGGED
-B: BULK PACKAGED (QTY=100 MAX)

TERMINATION
-CA3: CABLE (RG179)

ORIENTATION
-ST: STRAIGHT

TABLE 1			
ITEM	COMPONENT	-HN	-H
1	SUB ASSEMBLY	SUB-MCX7-P-C-FN-ST-CA3	SUB-MCX7-P-C-F-ST-CA3
2	PIN	MCX7-P-C-H-ST-CA3-PIN	
3	OUTER FERRULE	MCX-FER-001-N	MCX-FER-001-F

PLATING SPECIFICATION

-HN: 30µ" GOLD CENTER CONTACT, 100µ" NICKEL OUTER CONTACT
-H: 30µ" GOLD CENTER CONTACT, 3µ" GOLD OUTER CONTACT (SEE TABLE 1)

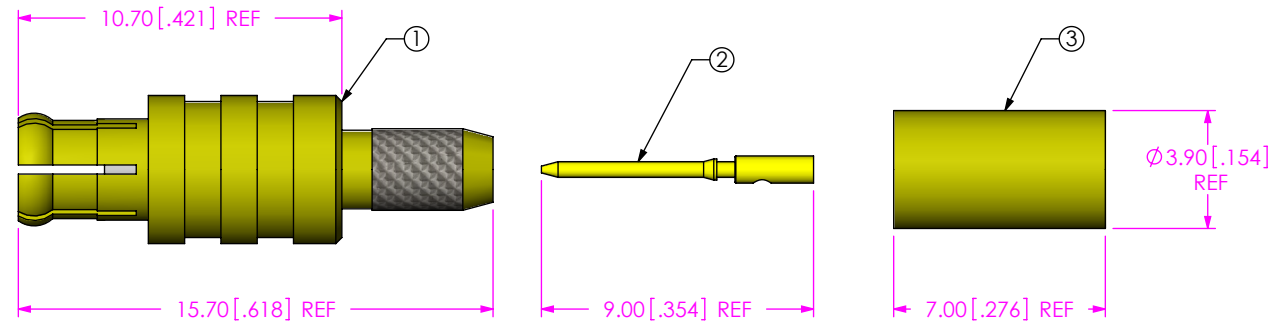

NOTES:

1. NOTE DELETED.
2. NOTE DELETED.
3. NOTE DELETED.
4. NOTE DELETED.
5. PRODUCT TO BE PACKAGED PER PRECISION RF SECTION OF PACKAGING MANUAL.
6. NOTE DELETED.
7. NOTE DELETED.
8. NOTE DELETED.

F:\DWG\MISC\MKTG\MCX7-P-C-XX-ST-CA3-X-MKT.SLDDRW

UNLESS OTHERWISE SPECIFIED, DIMENSIONS ARE IN MILLIMETERS [INCHES].
TOLERANCES ARE:
DECIMALS ANGLES
.X: ±0.3 [.01] 5°
.XX: ±0.13 [.005]
.XXX: ±0.051 [.0020]

PROPRIETARY NOTE
THIS DOCUMENT CONTAINS CONFIDENTIAL AND PROPRIETARY INFORMATION AND ALL DESIGN, MANUFACTURING, REPRODUCTION, USE, PATENT RIGHTS AND SALES RIGHTS ARE EXPRESSLY RESERVED BY SAMTEC, INC. THIS DOCUMENT SHALL NOT BE DISCLOSED, IN WHOLE OR PART, TO ANY UNAUTHORIZED PERSON OR ENTITY NOR REPRODUCED, TRANSFERRED OR INCORPORATED IN ANY OTHER PROJECT IN ANY MANNER WITHOUT THE EXPRESS WRITTEN CONSENT OF SAMTEC, INC.

MATERIAL: DO NOT SCALE DRAWING SHEET SCALE: 4:1
SHELL, FERRULES: BRASS
CONTACT: BRASS
DIELECTRIC: PTFE



520 PARK EAST BLVD, NEW ALBANY, IN 47150
PHONE: 812-944-6733 FAX: 812-948-5047
e-Mail info@SAMTEC.com code 55322

DESCRIPTION:
TRUE 75 OHM, MCX STRAIGHT PLUG, RG179
DWG. NO.
MCX7-P-C-XX-ST-CA3-X
BY: R MUSSER 02/06/2008 SHEET 1 OF 3

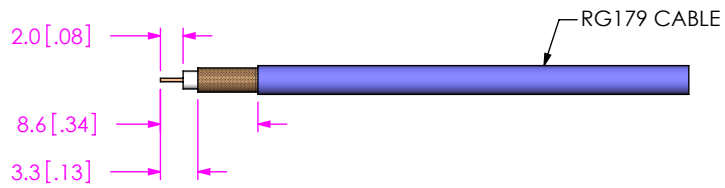

IN-PROCESS 1
STRIP CABLE AND TIN INNER CONDUCTOR

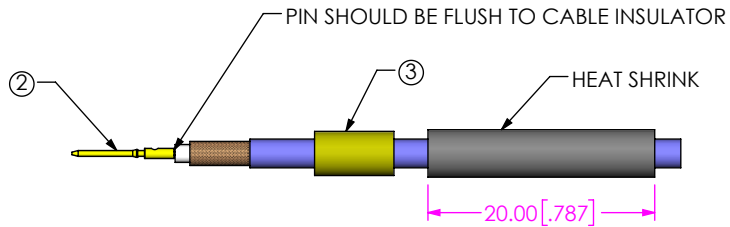

IN-PROCESS 2
ADD HEAT SHRINK TUBING AND FERRULE, SOLDER SIGNAL PIN

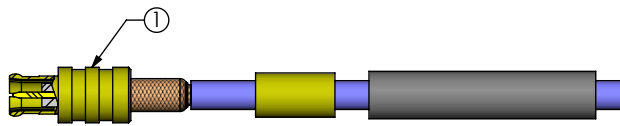

IN-PROCESS 3
FLARE SHIELD & ADD SUB ASSEMBLY

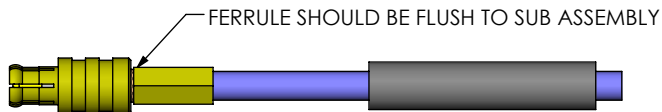

IN-PROCESS 4
CRIMP FERRULE
(USE RF CRIMP HAND TOOL #CAT-RF-FER-01, AND USE .128" HEX DIE)



IN-PROCESS 5
ACTIVATE HEAT SHRINK

PROPRIETARY NOTE
THIS DOCUMENT CONTAINS CONFIDENTIAL AND PROPRIETARY INFORMATION AND ALL DESIGN, MANUFACTURING, REPRODUCTION, USE, PATENT RIGHTS AND SALES RIGHTS ARE EXPRESSLY RESERVED BY SAMTEC, INC. THIS DOCUMENT SHALL NOT BE DISCLOSED, IN WHOLE OR PART, TO ANY UNAUTHORIZED PERSON OR ENTITY NOR REPRODUCED, TRANSFERRED OR INCORPORATED IN ANY OTHER PROJECT IN ANY MANNER WITHOUT THE EXPRESS WRITTEN CONSENT OF SAMTEC, INC.

DO NOT SCALE DRAWING

SHEET SCALE: 1.5:1



520 PARK EAST BLVD, NEW ALBANY, IN 47150
PHONE: 812-944-6733 FAX: 812-948-5047
e-Mail info@SAMTEC.com code 55322

DESCRIPTION:
TRUE 75 OHM, MCX STRAIGHT PLUG, RG179

DWG. NO.
MCX7-P-C-XX-ST-CA3-X

BY: R MUSSER 02/06/2008 SHEET 2 OF 3

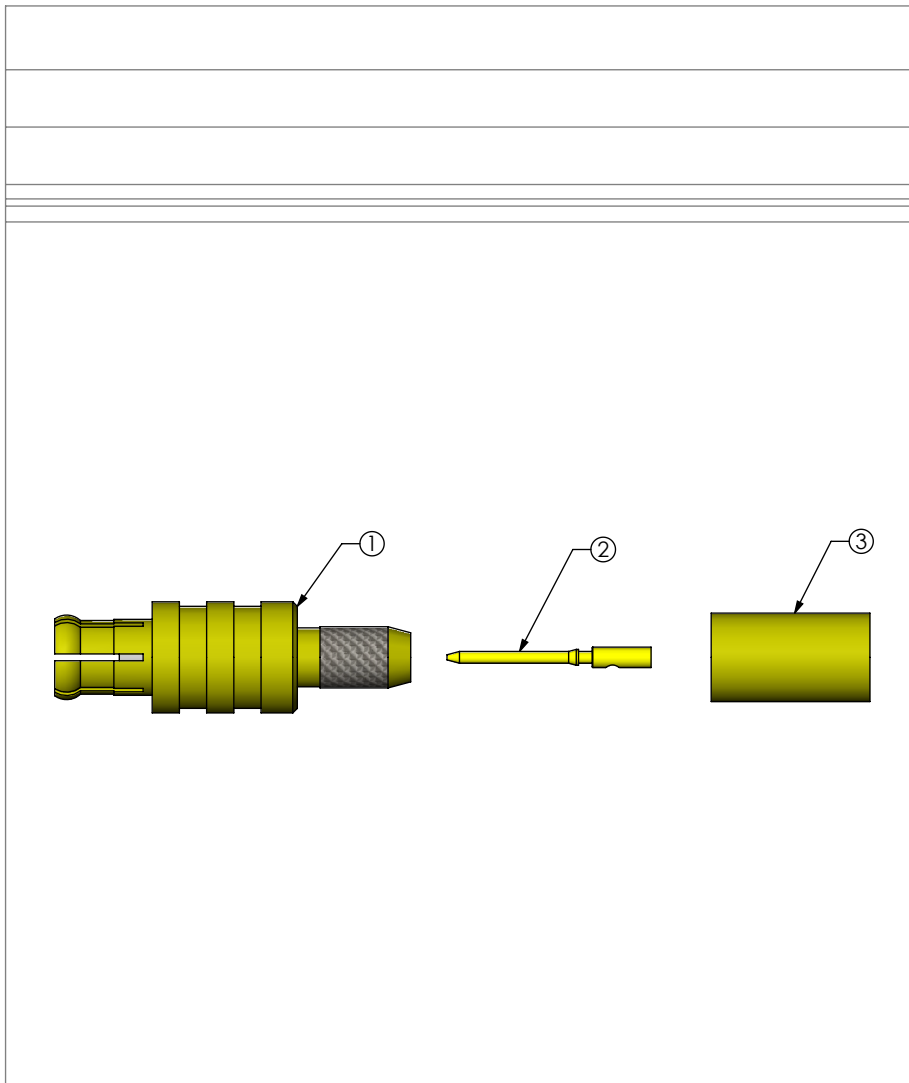

MCX7-P-C-XX-ST-CA3 SHOWN

<p>PROPRIETARY NOTE</p> <p>THIS DOCUMENT CONTAINS CONFIDENTIAL AND PROPRIETARY INFORMATION AND ALL DESIGN, MANUFACTURING, REPRODUCTION, USE, PATENT RIGHTS AND SALES RIGHTS ARE EXPRESSLY RESERVED BY SAMTEC, INC. THIS DOCUMENT SHALL NOT BE DISCLOSED, IN WHOLE OR PART, TO ANY UNAUTHORIZED PERSON OR ENTITY NOR REPRODUCED, TRANSFERRED OR INCORPORATED IN ANY OTHER PROJECT IN ANY MANNER WITHOUT THE EXPRESS WRITTEN CONSENT OF SAMTEC, INC.</p>	 <p>520 PARK EAST BLVD, NEW ALBANY, IN 47150 PHONE: 812-944-6733 FAX: 812-948-5047 e-Mail info@SAMTEC.com code 55322</p>
<p>DO NOT SCALE DRAWING SHEET SCALE: 4:1 INSULATOR: BRASS C3604B CONTACT OR TERMINAL: SHIELD: PHOS BRONZE PLATING: CONTACT AREA: .000010 REF GOLD REMAINDER: .000200 REF TIN</p>	<p>DESCRIPTION: TRUE 75 OHM, MCX STRAIGHT PLUG, RG179 DWG. NO. MCX7-P-C-XX-ST-CA3-X BY: R MUSSER 02/06/2008 SHEET 3 OF 3</p>