

# MI0603J102R-10

## PHYSICAL DIMENSIONS:

A	1.60 [.063]	$\pm$	0.15	[.006]
B	0.80 [.031]	$\pm$	0.15	[.006]
C	0.80 [.031]	$\pm$	0.15	[.006]
D	0.36 [.014]	$\pm$	0.15	[.006]

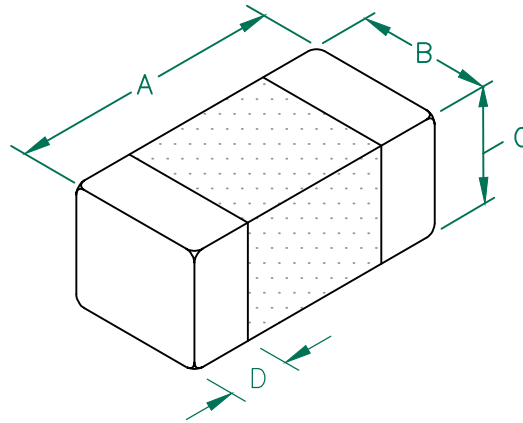

## ELECTRICAL CHARACTERISTICS:

Z @ 100MHz ( $\Omega$ )	DCR ( $\Omega$ )	Rated Current
Nominal	1000	
Minimum	750	
Maximum	1250	0.20
		1000 mA

NOTES: UNLESS OTHERWISE SPECIFIED

1. TAPED AND REELED per CURRENT EIA SPECIFICATIONS 7" REELS, 4000 PCS/REEL. PAPER TAPE.
2. TERMINATION FINISH IS 100% TIN.
3. COMPONENTS SHOULD BE ADEQUATELY PREHEATED BEFORE SOLDERING.
4. OPERATING TEMP. RANGE:  $-55^{\circ}\text{C} \sim +125^{\circ}\text{C}$  (INCLUDING SELF-HEATING)

Z vs FREQUENCY  
IMPEDANCE UNDER DC BIAS

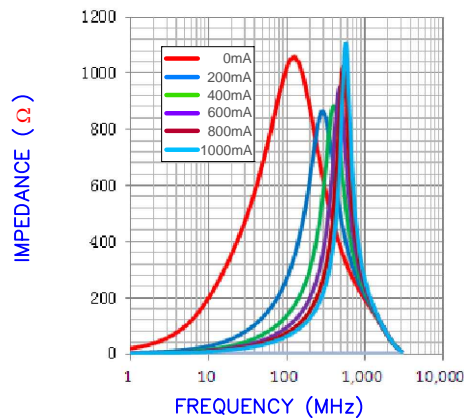

LAND PATTERNS FOR REFLOW SOLDERING

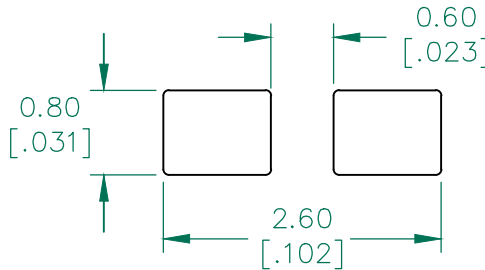

(For wave soldering, add 0.762 [.030] to this dimension)

RECOMMENDED SOLDERING CONDITIONS

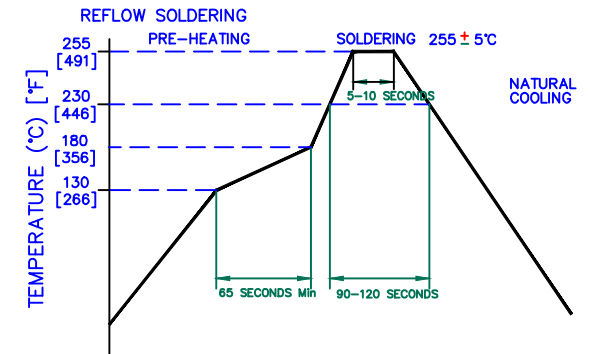

|Z|, R, AND X vs. FREQUENCY

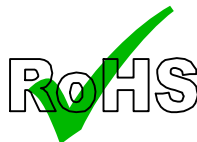
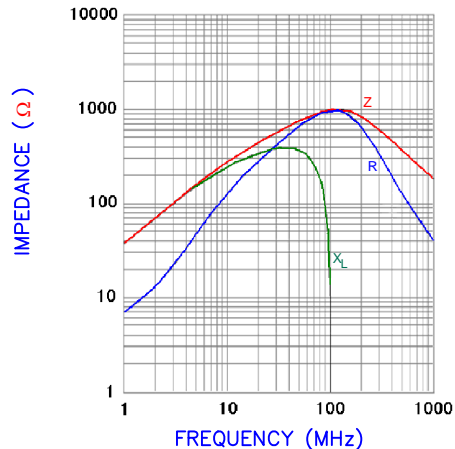

DIMENSIONS ARE IN mm [INCHES].

This print is the property of Laird Tech. and is loaned in confidence subject to return upon request and with the understanding that no copies shall be made without the written consent of Laird Tech. All rights to design or invention are reserved.



PROJECT/PART NUMBER:

MI0603J102R-10

REV C PART TYPE: CO-FIRE DRAWN BY: QU

REV	DESCRIPTION	DATE	INT	DATE:	SCALE:	SHEET:
C	UPDATE LAIRD LOGO AND NOTES 4	08/05/13	QU	11/26/12	-	2 of 2
B	ADD DC BIAS CURVE	11/26/12	QU			
A	ORIGINAL DRAFT	03/01/09	QU			
REV				CAD #	TOOL #	