

D-Subminiature connectors

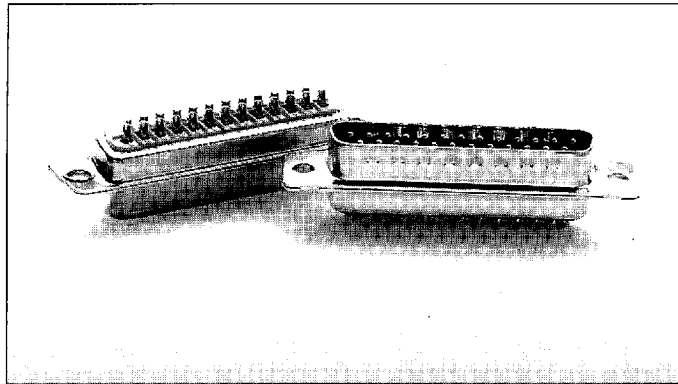

Solder cup

Socket connector

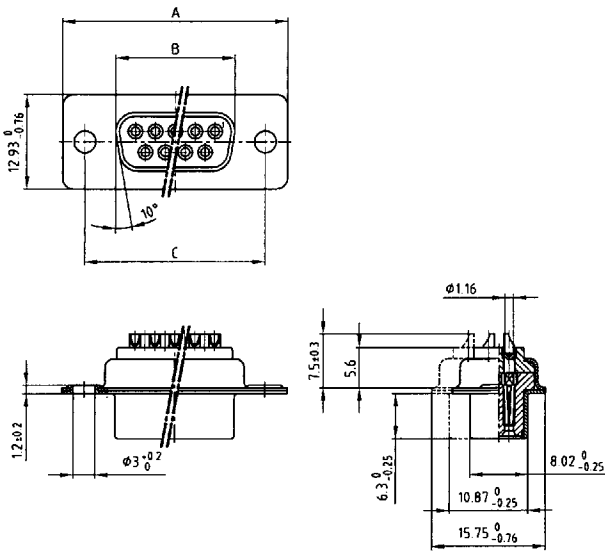

Solder cup accepts cable AWG 20

Plug connector

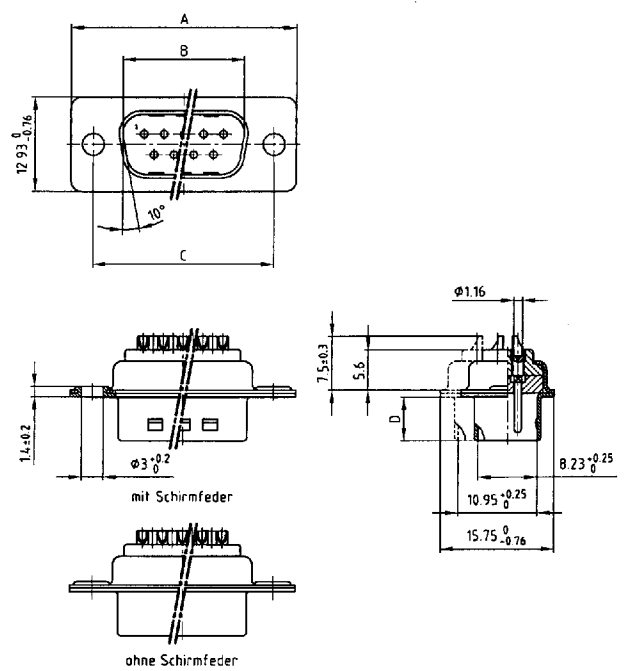

Kat 1 i F2A

No. of pos.	A - 0,76	B - 0,25	C
9	31,19	16,46	25,00 ^{+0.12} _{-0.15}
15	39,52	24,79	33,30 ^{+0.15} _{-0.10}
25	53,42	38,50	47,04 ^{+0.13}
37	69,70	54,96	63,50 ^{+0.13}
50	67,31	52,55	61,10 ^{+0.11}

Kat 1 i F3A

No. of pos.	A - 0,76	B + 0,25	C	D - 0,30
9	31,19	16,79	25,00 ^{+0.12} _{-0.15}	6,12
15	39,52	25,12	33,30 ^{+0.15} _{-0.10}	6,12
25	53,42	38,84	47,04 ^{+0.13}	5,99
37	69,70	55,30	63,50 ^{+0.13}	5,99
50	67,31	52,68	61,10 ^{+0.11}	5,99

Part numbers

No. of Pos.	Socket connector – solder cup	
	yellow zinc	tin-plated
9	CDF 09 L	CDF 09 LSN
	162 A 10019 X	164 A 10019 X
15	CDF 15 L	CDF 15 LSN
	162 A 10029 X	164 A 10029 X
25	CDF 25 L	CDF 25 LSN
	162 A 10039 X	164 A 10039 X
37	CDF 37 L	CDF 37 LSN
	162 A 10049 X	164 A 10049 X
50	CDF 50 L	CDF 50 LSN
	162 A 10059 X	164 A 10059 X

No. of Pos.	Plug connector – solder cup	
	yellow zinc without ground indent	tin-plated with ground indent
9	CDS 09 L	CDS 09 LFSN
	161 A 10019 X	163 A 11069 X
15	CDS 15 L	CDS 15 LFSN
	161 A 10029 X	163 A 11079 X
25	CDS 25 L	CDS 25 LFSN
	161 A 10039 X	163 A 11089 X
37	CDS 37 L	CDS 37 LFSN
	161 A 10049 X	163 A 11099 X
50	CDS 50 L	CDS 50 LFSN
	161 A 10059 X	163 A 11109 X

Part Number

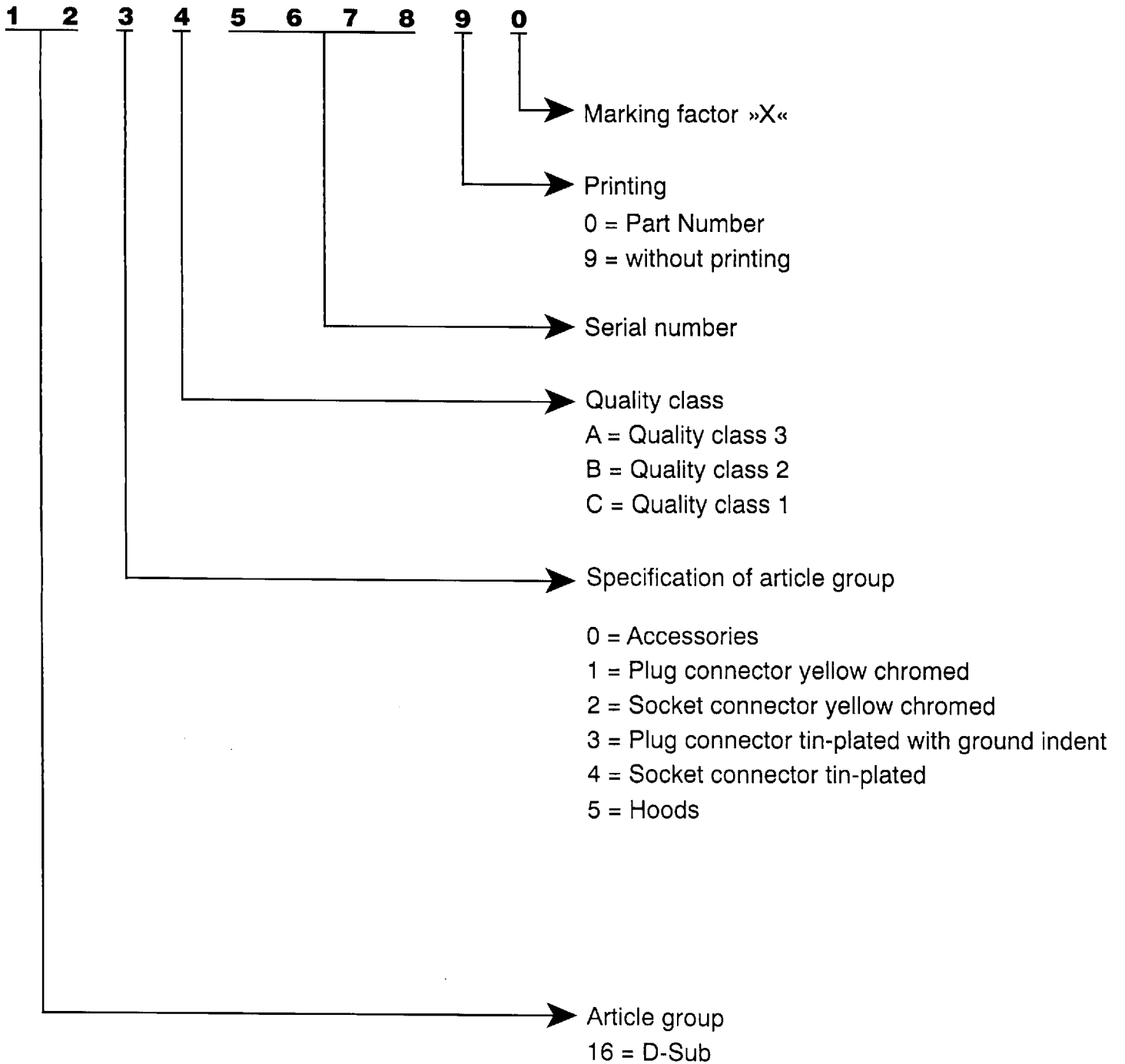

Order example

Plug connector Solder bucket 25 pos. without printing	
Quality class	Part Number
3	CDS 25 L 161 A 10039 X
2	CDS 25 L 161 B 10039 X
1	CDS 25 L 161 C 10039 X

9017935 0000071 237

Technical Data	D-Sub Standard	D-Sub High Density
Initial contact resistance	≤ 10 mΩ	≤ 10 mΩ
Initial insulation resistance	Quality class 1 ≥ 5GΩ Quality class 2 ≥ 5GΩ Quality class 3 ≥ 5GΩ	Quality class 1 ≥ 5GΩ Quality class 2 ≥ 5GΩ Quality class 3 ≥ 5GΩ
Clearance distance	contact–contact ≥ 1.0 mm contact–ground ≥ 1.2 mm	≥ 0.6 mm
Creepage distance	contact–contact ≥ 1.0 mm contact–ground ≥ 1.2 mm	≥ 0.6 mm
Test voltage V. r. m. s./NM	1000 V	1000 V
Working voltage/Insulation group* * nach SEV 50 V – acc. to SEV 50 V	125 V ≈	60 V ≈
Working current 20° C	5 A max.	25 A max.
Operating temperature	- 55° C – + 125° C	- 55° C – + 125° C
Moulding material	Polyester GF UL 94 V-O	PA 6.6 GF 25 UL 94 V-O
Contact material	Copper alloy	Copper alloy
Contact finish	hard-gold-plated over nickel	hard-gold-plated over nickel
Shell	Sheet steel, zinc lined and yellow chromate Sheet steel, nickel underneath and tin-plated	Sheet steel, nickel underneath and tin-plated
Insertion and withdrawal forces	9-polig/way 30 N 15-polig/way 50 N 25-polig/way 83 N 37-polig/way 123 N 50-polig/way 167 N	15-polig/way 50 N 26-polig/way 84 N 44-polig/way 120 N 62-polig/way 170 N 78-polig/way 200 N
Quality classes	Quality class 1 Quality class 2 Quality class 3	500 mating cycles 200 mating cycles 50 mating cycles