



ISO 9001 : 2008 CERTIFIED

DESIGNERS & MANUFACTURERS OF KNOBS, HANDLES, CASES & CUSTOM PLASTIC COMPONENTS

**Specializing in Insert-Molded Knobs,  
Handles, Cases, and Custom Plastic  
Components Since 1933**

---

## 2013 Standard Parts Catalog

---

**CLAMPING KNOBS**

**CONTROL KNOBS**

**BALL KNOBS**

**LEVER KNOBS**

**PUSH/PULL KNOBS**

**APPLIANCE KNOBS**

**SPECIALTY KNOBS**

**SOFT TOUCH/ 2 SHOT KNOBS**

**PLASTIC HANDLES**

**GENERAL PURPOSE HANDLES**

**ALUMINUM HANDLES**

**STAINLESS STEEL HANDLES**

**MULTIPURPOSE HANDLES**

**CLEAN LINE COMPONENTS**

**CASES & COVERS**

**CUSTOM PLASTIC COMPONENTS**



# Table of Contents

## Information

About Davies Molding.....	3-6
Custom Molding.....	7
Online Resources .....	8
Soft Touch .....	9

## Clamping Knobs

Bar .....	10-11
Three Arm .....	12
Four Arm .....	13
Five & Six Arm.....	14
Trigon.....	15
Husky .....	15
Four Lobe .....	16
Seven Lobe .....	17
Round Grip.....	18
Fluted Clamping.....	19
Knurled/Scalloped Clamping.....	20-21
Mini Clamping.....	22
Octagonal.....	23
Dominator .....	24
Leo .....	25

## Control Knobs

Soft Touch 2 and 3 Shot.....	26-27
Collet Knobs .....	28
Instrument Knobs.....	29-31
Pointer Series .....	32-33
Skirted Knobs .....	34
Fluted Knobs with Skirts.....	35

## Ball Knobs

Deluxe .....	37
Standard .....	38
Thermoplastic.....	39
Lever .....	40-41
Push/Pull .....	42-43

## Handles

Tapered .....	44
Fluted Tapered .....	45
Two Point/ Pull .....	46-47
Ratchet.....	48
Adjustable.....	49
Fixed Position.....	49
Appliance .....	50
Side.....	51

## Specialty Shapes

.....	36
-------	----

## Feet and Levelers

.....	52
-------	----

## Cases and Covers

.....	53-54
-------	-------

## General Purpose Handles

Handle Series MS.....	55
Handle Series EC.....	56
Handle Series KW.....	57
Handle Series KM.....	58
Handle Series KS.....	59
Handle Series KK.....	60
Handle Series MA.....	61
Handle Series SK.....	62

## Aluminum Handles

Aluminum R Series.....	63
Aluminum KG Series.....	64
Aluminum SK Series .....	65
Aluminum S Series.....	66
Aluminum RA Series .....	67
Aluminum OA Series.....	68
Aluminum MO Series.....	69
Aluminum RR Series .....	70
Aluminum MF Series.....	71
Cranked Machine Handles AM.....	71

## Steel Handles

Round Bar Steel ST Series.....	72
Round Bar Steel EF Series.....	73
Stainless Steel MK Series.....	74

## Multipurpose Handles

Handle Series RS.....	75-76
Handle Series UG .....	77-80

## Legs and Feet

Extension Legs GZ.....	81
Casing Feet GK .....	82
Casing Feet GG.....	82

## Clean Line

Handle Series R1 and S1 .....	83
Handle Series OA & MF.....	84
Handle Series MO .....	85
Handle Series SG .....	86
Knob Series BM.....	87
Knob Series BT .....	88
Knob Series BL.....	89

# About Davies Molding

As a designer and manufacturer of top quality plastic components, Davies Molding provides more than 80 years of molding experience to our customers. We specialize in insert-equipped standard and custom thermoplastic and thermoset plastic parts. Davies is known for having the world's most extensive line of knobs. Our standard product line also includes a diversified selection of handles and cases. Secondary operations include hot stamping, drilling, pad printing, and engraving. Davies' progressive, new management is dedicated to offering you the best possible customer service, including prompt quotes and expeditious fulfillment. Utilizing the latest 3-D CAD software, our engineers can help you create innovative plastic parts. In addition to molding, Davies offers contract manufacturing, assembly and packaging for the value-added performance you expect from a supplier.

## Representative Industries Served, But Are Not Limited To:

- |                        |                      |                      |
|------------------------|----------------------|----------------------|
| ■ Electronics          | ■ Power Tool         | ■ Cookware           |
| ■ Instrumentation      | ■ Food Processing    | ■ Recreation/Fitness |
| ■ Industrial/Machinery | ■ Medical/Laboratory | ■ Lawn & Garden      |

## Secondary Operations/Finishing Services:

- |                |  |
|----------------|--|
| ■ Hot Stamping | Illustrated on this page are some of the more than 1,000 parts that have been customized to provide our customer with specific logos, calibrations or decoration to enhance the unit to meet customer needs, with minimal amount of tooling. Send us your sketch or print for quotation. |
| ■ Drilling     |  |
| ■ Pad Printing |  |

- Engraving
- Ultrasonic Welding
- Branding
- Paint Fill
- Decorative Pointers
- Machining
- Turning
- Tapping
- Bagging
- Buff and Polish
- Sand Blasting
- 3-D CAD Imaging
- Assembly
- Packaging
- Custom Color
- Silk Screen
- Decorative Inlays
- Plating on Plastics



# General Information

This is a catalog of standard plastic parts for which we have proprietary tooling. We offer you these parts for your purchase without any tooling cost being involved. If your product requires a slight variance from our listings, it is likely it can be furnished to you at a moderate cost.

It is not our intent to keep in stock all of the many variations described in this catalog. We do, however, endeavor to keep all standard raw materials on hand in order that delivery lead times can be kept to a minimum.

Davies Molding guarantees that it will supply its customers with parts which are of good commercial quality. These parts are to be free of cracks and blisters, and are of mechanical strength commensurate with the plastic material used and the design of the product. Specific requirements can be met with tooling and/or material changes. Please contact customer service for guidance.

Davies Molding has no control over the end use of its products; therefore, we cannot accept liability for any loss or failure incurred by the purchaser other than replacement of items which we manufactured that are judged to be of less than good commercial quality. Customer acceptance of a shipment from Davies Molding L.L.C. will constitute acknowledgement that the parts are of good commercial quality.















The appearance of our parts will be deemed to be of good commercial quality when flaws are not noticed under the following conditions: viewed in normal incandescent or fluorescent light at a distance of at least 24 inches and for a period of not more than three seconds. Again, special appearances requirements can be met—contact customer service.

We suggest that the customer obtain a sample and test the part under the proposed end use conditions. Such samples are generally readily available at a modest charge, if any.

Claims for defective molded parts are not recognized if the part has been assembled, machined, altered or finished in any way after delivery to the customer.

## Colors

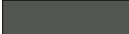
The standard color (as supplied to us) for phenolic (thermoset) material is black. Other colors are available at a slightly increased price. See below for the available standard colors in thermoset.

	2300-13 Red		732-25 Orange		732-16 Blue		732-03 Grey
	2567 Red		02300 Green		732-18 Yellow		548 Oak Mottle
	732-01 Red		732-14 Green		732-20 White		001 Black
					732-15 Dark Grey		002 Brown

\*Colors shown may not represent actual color—  
Please call for a sample.

Thermoplastic materials have a very wide range of available colors. In many cases we can match your color target.

There is an increase in price reflecting the cost of the color. We will be happy to assist you in making a color selection.



# General Information

## Customer Owned Material, Artwork, Supplies, Tooling

Davies Molding Company will store customer owned material, artwork, -supplies and tooling for use on future order requirement at no charge to customer. Items that have had no activity within any two year period will be considered of no value and we will notify the owner of this situation and request disposition. The customer's failure to respond to our letter will leave the disposition of the items at the discretion of Davies Molding L.L.C.\*5 at no cost or obligation.

## Terms & Conditions

For production parts, our terms are Net 30 days, F.O.B. our dock. Penalties for late payment will be assessed at a rate of 1.5% per month on the unpaid balance. All tool charges are due 50% with order and balance upon completion of tooling. Less than \$500.00 is due with order. Additional terms for custom molding are listed on our quotation forms.

## Quality Variance

We reserve the right to over or under ship 10% of order or release quantities. A greater percentage may be necessary for colors other than black and special inserts. Should exact quantities be mandatory, consult the factory for the premium charge necessary for this special requirement.

## Damage, Shortage

Damages or shortages in shipments en route: Our responsibility does not extend beyond our plant. Examine all shipments carefully before the delivering carrier leaves your premises. Where damage or shortage has occurred be sure and have the freight bill (truck freight shipments) show this and have it signed by the driver. Parcel post damages are to be reported to us immediately. United Parcel Delivery damages are to be taken up with the driver making the delivery. Concealed damage claims must be made within forty-eight hours. In all instances we will attempt to assist you in securing adjustment providing you follow the above recommendations.

## Insert Types:

### Threaded Insert:

- Common Names: Female Insert, Blind Insert, or Internal Threads.
- Standard Material: Brass or steel, zinc plated.
- Features: Molded into the plastic to provide optimum strength.



### Threaded Insert Thru-Hole:

- Common Name: Thru-Hole Insert.
- Standard Material: Brass or steel, zinc plated.
- Features: Molded into the plastic to provide optimum strength.



### Projecting Stud:

- Common Names: Male Insert, Stud, or External Threads.
- Standard Material: Steel, zinc plated.
- Features: Molded into the plastic to provide optimum strength.



### Bushing:

- Standard Material: Brass or steel, zinc plated.
- Features: Molded into the plastic to provide optimum strength, no internal threads, and can be used in conjunction with set screws.



### Set Screw:

- Standard Types: Slotted (pictured right, top) and socket head (pictured right, bottom)
- Standard Material: Steel, zinc plated, or black oxide finish.
- Features: One or multiple set screws used to keep knob in place (used in conjunction with a bushing or plain hole).



### Hex Nut:

- Standard Types: Standard (pictured right, top) or with a nylon locking ring (pictured right, bottom).
- Standard Material: Steel, zinc plated.
- Features: Molded into the plastic to provide optimum strength; thru-hole; nylon locking ring prevents loosening.



### Cap or Disk:

- Standard Material: Aluminum.
- Features: Used for decoration, or as a pointer when an indicator line is present; a disk is recessed (pictured right, top) and a cap is raised (pictured right, bottom).



# General Information

## Material

Davies Molding uses only the best molding materials available. We select these materials based on the end use of the product. Some of our items are produced from thermoset materials while others are thermoplastic. Our catalog describes the type material used in each product or product family. Only occasionally can substitutions be made, as the process is different for different materials.

These Raw Material Specifications shall not be construed as creating an express warranty. The specifications are approximate and are intended to serve only as guides and not as the basis of any sale, agreement, or contract, or of any goods sold. Davies Molding reserves the right to change the raw material of any of the goods contained in this catalog without notice to any buyer. Further, these Raw Material Specifications have been provided by the manufacturer and Davies Molding does not warrant their accuracy.

## GENERAL AVERAGE CHARACTERISTICS: THERMOSET and THERMOPLASTIC

### GENERAL PURPOSE PHENOLIC

Notched IZOD Impact-FT. LBS/IN	0.27 – 0.32
Tensile Strength at Break P.S.I.	5,000 MIN.
Hardness	Rockwell M100-115
Heat Resistance	325°F (163°C)
UL Flammability Rating	94V-0
Colors Available	Standard Black, Brown

### HEAT RESISTANT PHENOLIC

Notched IZOD Impact-FT. LBS/IN	0.29
Tensile Strength at Break P.S.I.	8,500 MIN.
Hardness	Rockwell M100-115
Heat Resistance	400°F (204°C)
Special Order	450°F (232°C)
UL Flammability Rating	94V-1
Colors Available	Standard Black, Brown

### MELAMINE PHENOLIC

Notched IZOD Impact-FT. LBS/IN	0.29
Tensile Strength at Break P.S.I.	6,200 MIN.
Hardness	Rockwell M100-115
Heat Resistance	300°F (149°C)
UL Flammability Rating	94V-0
Colors Available	Standard Black, Brown Limited to select colors manufactured by our supplier

### 30% GLASS FILLED NYLON

Notched IZOD Impact-FT. LBS/IN	2.1
Tensile Strength at Break P.S.I.	26,000
Hardness	Rockwell R-120
Heat Resistance	480°F (249°C)
UL Flammability Rating	HB
Colors Available	Natural, Black

### GENERAL PURPOSE 6/6 NYLON

Notched IZOD Impact-FT. LBS/IN	1.0
Tensile Strength at Break P.S.I.	11,000
Hardness	Rockwell R-118
Heat Resistance	160°F (71°C)
UL Flammability Rating	HB
Colors Available	Natural, Black

### 20% TALC FILLED POLYPROPYLENE

Notched IZOD Impact-FT. LBS/IN	1.5
Tensile Strength at Break P.S.I.	3,000
Hardness	Rockwell R-65

\*Most colors can be matched

## Packaging

Davies uses quality commercial packing for its shipments. Special packaging is available and will be quoted upon written request prior to receipt of orders.

Special note: While we do not claim to use fancy packaging, we always try to assure that it is functional and neat. We have studied our packaging with renowned packaging consultants. We have been assured that our method of packaging is suitable for shipping but not for the abusive handling that can occasionally occur in mail and U.P.S. type shipments. These carriers are prepared to accept claims made for damage in transit.

# Custom Molding

## 80 Years Experience

Davies Molding has the know-how in efficient, economical, and quality conversion of product design into finished plastic product. This know-how extends from management and production engineers to skilled machine operators.

## Quality Control

The quality control that begins at our receiving dock with resin and insert delivery continues through our entire molding and finishing operations.

Davies specializes in custom molded knobs and handles using special inserts or one of our thousands of stock inserts. Send a sketch or print for quick pricing.

## 76 Molding Presses

50 to 400 tons for both thermoset and thermoplastic materials, inline screw injection, shuttle, semi-automatic, and rotary equipment for molded only and insert molding.

## Tool Room

Expertly staffed and equipped to build new molds and maintain present tooling. Allows for better control of mold quality and delivery schedules.

## Engineering

Experienced field agents are located in the principal cities of the United States and Canada to give you prompt service and practical advice on any plastic problems you may have. To augment the field staff, technically trained plastic engineers are available from the plant to help you design your parts to take advantage of the most economical method of molding and finishing.

## Finishing

87 machines provide the most efficient methods for almost any secondary operations that may be required. Drilling, tapping, hot stamping, pad printing, engraving, paint filling, sanding, grinding, milling and assembly of inserts, set screws, springs, decorative inlays, and skirts.

## Davies Quality Custom Molding Solutions

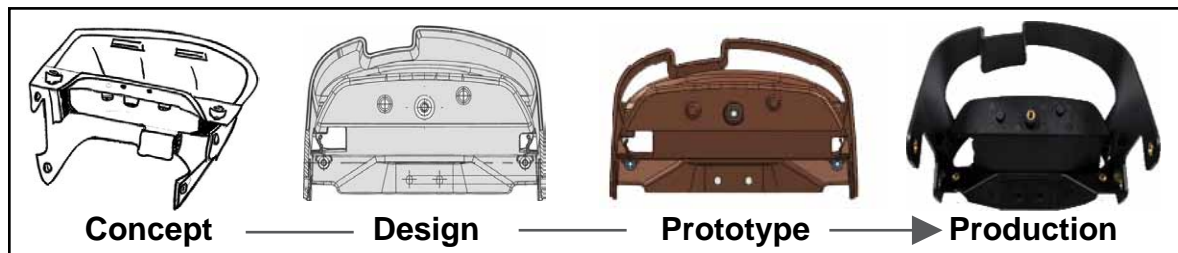

View our Custom Products Portfolio at [plastic-molding.daviesmolding.com](http://plastic-molding.daviesmolding.com)



# Online Resources

[www.daviesmolding.com](http://www.daviesmolding.com)

Visit our website for additional resources to help you find your ideal part!

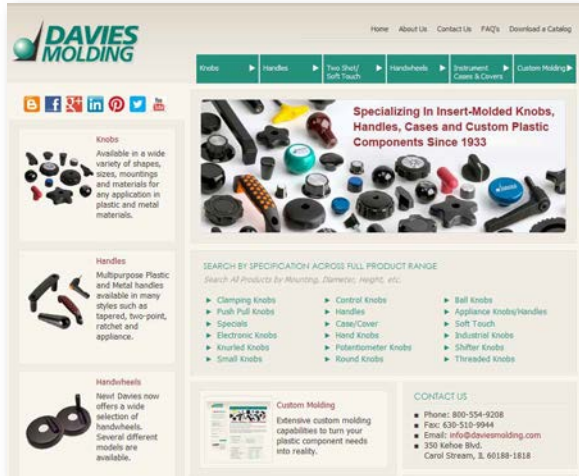

**Search by part #, diameter, insert threads, and more!**

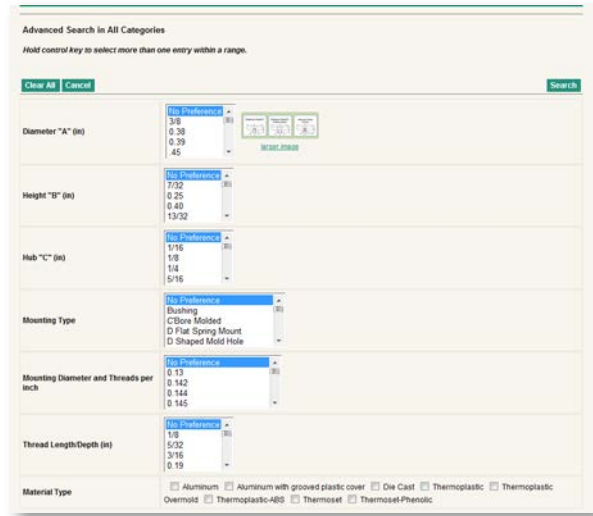

**View and download your part in 2-D or CAD drawing**

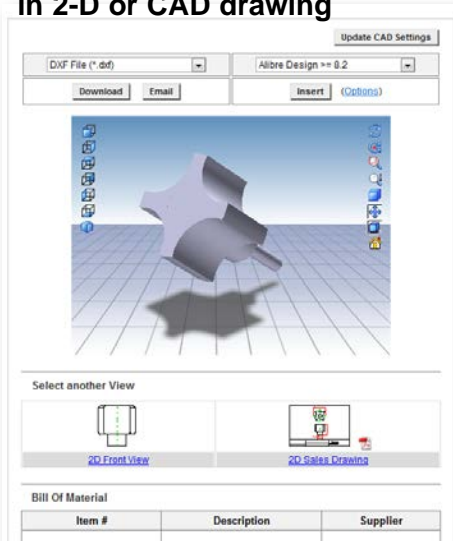

**Learn about custom molding in our project portfolio**

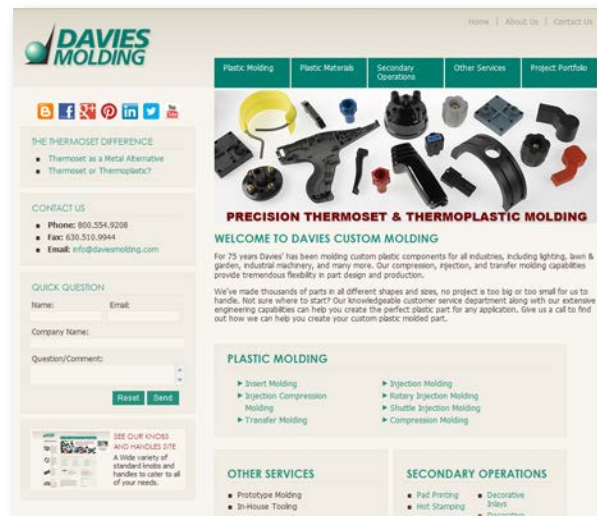

**Socialize with us!**



Learn about new products and innovations in manufacturing. Join our discussions on current industry topics and find resources to help build the right part for your application.

GENERAL INFORMATION



# NEW! 2 and 3 Shot Soft Touch Line

Molded with a soft thermoplastic overmolded "rubber" top with a tough thermoplastic substrate

Provides a non-slip, comfortable grip that is durable and resistant to scratches

Variety of sizes, styles, and color combinations

Custom finishes, including logo printing available

## Instrument Control

Available in a wide range of sizes and styles. Female insert, plain molded hole, spring mounting, and interference fit options are available. New! - Three-shot instrument control knobs available.



## Skirted Controls

One of our most versatile products that provides extra comfort, style, and high quality function. Female insert, plain molded hole, and spring mounting options are available.



## Clamping Knobs

Currently available in our Four Lobes and Five Lobes Clamping categories. Molded with an engineered thermoplastic elastomer with a tough inner core and molded in metal insert for high torque performance make these knobs unique, rugged, and ergonomical.



## Two-Point Handles

Our most popular two-shot handle! Davies two-shot and soft touch two-point handles are molded with glass-reinforced nylon and a thermoplastic elastomer to provide extra comfort and style.



## Custom Components

We specialize in custom plastic molded components for a variety of applications. Utilizing the latest CAD and 3-D modeling software, our engineering staff will help you create the exact look, feel, and dimensions of your ideal plastic part.



# Bar

Always functional and always in style. Excellent variety of sizes and finishes, for any need. Can be decorated. Knob specifications include a brass insert, steel, zinc plated projecting stud, and hex nut.

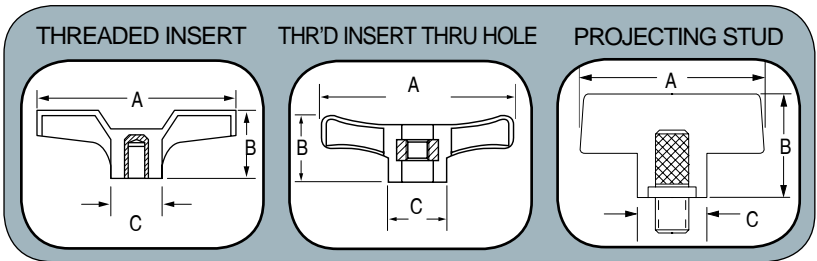

Material Type	Part No.	A Dia.	B Current Part Height	C Part Height Capab.	Hub Dia.	Threaded Female Insert												Threaded Male Stud*												Threaded Female Insert Thru-Hole																							
						8-32												10-32												10-32												10-32											
						8-32	10-24	10-32	1/4-20	1/4-28	5/16-18	5/16-24	3/8-16	3/8-24	1-2/13	1/2-20	8-32	10-24	10-32	1/4-20	1/4-28	5/16-18	5/16-24	3/8-16	3/8-24	1-2/13	1/2-20	8-32	10-24	10-32	1/4-20	1/4-28	5/16-18	5/16-24	3/8-16	3/8-24	1-2/13	1/2-20															
TP	2030	2 1/2	3/4	.750-1.00	3/4	■	▲	▲	▲	▲	▲	▲	▲	▲	▲	▲	▲	▲	▲	▲	▲	▲	▲	▲	▲	▲	▲	▲	▲	▲	▲	▲																					
TP	2031	2 1/2	1	.750-1.00	3/4	■	▲	▲	▲	▲	▲	▲	▲	▲	▲	▲	▲	▲	▲	▲	▲	▲	▲	▲	▲	▲	▲	▲	▲	▲	▲	▲																					
TP	2032	2 1/2	3/4	.750-1.00	3/4							▲	▲	▲	▲	▲	▲	▲	▲	▲	▲	▲	▲	▲	▲	▲	▲	▲	▲	▲	▲																						
TP	2033	2 1/2	1	.750-1.00	3/4							▲	▲	▲	▲	▲	▲	▲	▲	▲	▲	▲	▲	▲	▲	▲	▲	▲	▲	▲	▲																						
TP	2034	2 1/2	1 1/4	N/A	1/2	▲	▲	▲	▲	▲	▲	▲	▲	▲	▲	▲	▲	▲	▲	▲	▲	▲	▲	▲	▲	▲	▲	▲	▲	▲	▲																						
TP	3087	1 1/8	23/32, 1, 1 7/32	.700-1.250	1/2	▲	▲	▲	▲	▲	▲	▲	▲	▲	▲	▲	▲	▲	▲	▲	▲	▲	▲	▲	▲	▲	▲	▲	▲	▲	▲																						
TP	3088	2 1/2	45/64, 1 1/8, 1 1/4	.700-1.250	3/4	▲	▲	▲	▲	▲	▲	▲	▲	▲	▲	▲	▲	▲	▲	▲	▲	▲	▲	▲	▲	▲	▲	▲	▲	▲	▲	▲																					
TP	3089	2	3/4, 1 1/8, 1 9/16, 1 3/4	.750-1.750	3/4	▲	▲	▲	▲	▲	▲	▲	▲	▲	▲	▲	▲	▲	▲	▲	▲	▲	▲	▲	▲	▲	▲	▲	▲	▲	▲	▲																					
TP	3091	1 1/2	3/4	N/A	3/4	▲	▲	▲	▲	▲	▲	▲	▲	▲	▲	▲	▲	▲	▲	▲	▲	▲	▲	▲	▲	▲	▲	▲	▲	▲	▲	▲																					
TP	3093	3	1 11/64	N/A	25/32	▲	▲	▲	▲	▲	▲	▲	▲	▲	▲	▲	▲	▲	▲	▲	▲	▲	▲	▲	▲	▲	▲	▲	▲	▲	▲	▲																					
TP	3094	3 1/2	1 1/8	N/A	15/16	▲	▲	▲	▲	▲	▲	▲	▲	▲	▲	▲	▲	▲	▲	▲	▲	▲	▲	▲	▲	▲	▲	▲	▲	▲	▲	▲																					
TP	3098	3 3/8	1	N/A	1 1/8																																																
TS	3090	2	3/4, 25/32, 51/64, 1 1/8	.656-1.25	3/4	▲	▲	▲	▲	▲	▲	▲	▲	▲	▲	▲	▲	▲	▲	▲	▲	▲	▲	▲	▲	▲	▲	▲	▲	▲	▲	▲																					
TS	3092	2 1/2	1 1/8, 1 5/32	.687-1.156	3/4	▲	▲	▲	▲	▲	▲	▲	▲	▲	▲	▲	▲	▲	▲	▲	▲	▲	▲	▲	▲	▲	▲	▲	▲	▲	▲	▲																					
TS	3085	1 1/8	3/4, 7/8, 59/64, 1 1/4	.656-1.309	1/2	■	■	■	■	■	■	■	■	■	■	■	■	■	■	■	■	■	■	■	■	■	■	■	■	■	■	■																					
TP	3099	1 31/32	1 9/64	N/A	3/4																																																

\* For parts with male studs. LENGTH projecting below knob must be specified.  
 ■ Currently Manufacture/Tooled  
 ▲ Could Manufacture/Requires Tooling  
 TS Thermoset  
 TP Thermoplastic









Very durable knob in our popular triangular shape. Available in both thermoplastic and phenolic materials. Engraving, hot stamping, and pad printing available for all parts.

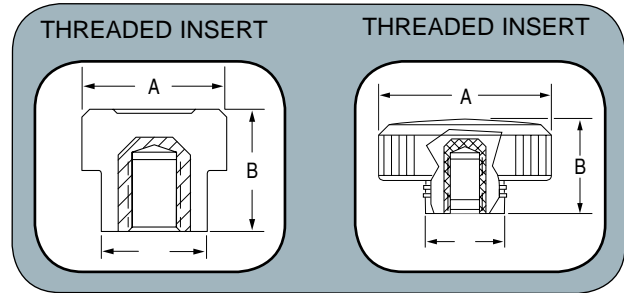

3072/3073/3075

Material Type	Part No.	A Dia.	B Current Part Height	C Part Height Capab.	Hub Dia.	Threaded Female Insert									Threaded Male Stud*									Threaded Female Insert Thru-Hole																									
						8-32	10-24	10-32	1/4-20	1/4-28	5/16-18	5/16-24	3/8-16	3/8-24	1-2/13	1/2-20	8-32	10-24	10-32	1/4-20	1/4-28	5/16-18	5/16-24	3/8-16	3/8-24	1-2/13	1/2-20	8-32	10-24	10-32	1/4-20	1/4-28	5/16-18	5/16-24	3/8-16	3/8-24	1-2/13	1/2-20											
TP	3070	3/4	33/64, 5/8, 23/32	.813-1.000	15/32	■	■	■	■	▲							■	■	■	■				■	■	■	■							■	■	■	■												
TP	3071	1	13/16	.625-1.000	5/8	■	■	■	■	▲	■	■					■	■	■	■	▲				■	■	■	■	▲							■	■	■	■	▲									
TP	3076	2 1/4	1 7/64	N/A	23/32	▲	▲	▲	▲	■	■	■	■	▲			▲	▲	▲	▲	▲	▲				▲	▲	▲	▲	▲								▲	▲	▲	▲	▲	▲						
TP	3077	1 25/64	25/32	N/A	3/4	▲	▲	▲	▲	■	■	■	■	▲			▲	▲	▲	▲	▲	▲				▲	▲	▲	▲	▲								▲	▲	▲	▲	▲	▲						
TP	3078	1 1/18	11/16	N/A	1/2	▲	▲	▲	▲	■	■	■	■	▲			▲	▲	▲	▲	▲	▲				▲	▲	▲	▲	▲								▲	▲	▲	▲	▲	▲						
TS	3072	1 1/4	5/8, 7/8	.625-1.000	3/4	▲	▲	▲	▲	■	■	■	■	▲			▲	▲	▲	▲	▲	▲				▲	▲	▲	▲	▲								▲	▲	▲	▲	▲	▲						
TS	3073	1 5/8	13/16, 7/8	.750-1.000	3/4	▲	▲	▲	▲	■	■	■	■	▲			▲	▲	▲	▲	▲	▲				▲	▲	▲	▲	▲								▲	▲	▲	▲	▲	▲						
TS	3075	2 1/8	7/8, 1 13/64, 1 1/4	N/A	1	▲	▲	▲	▲	■	■	■	■	▲			▲	▲	▲	▲	▲	▲				▲	▲	▲	▲	▲								▲	▲	▲	▲	▲	▲						

\* For parts with male studs, LENGTH projecting below knob must be specified.  
 ■ Currently Manufacture/Tooled  
 ▲ Could Manufacture/Requires Tooling  
 TS Thermoset  
 TP Thermoplastic

# Husky

Just as its name implies, the Husky does the job. Available in both thermoplastic and phenolic materials. The Husky design guarantees you the best possible grip. Can be decorated.



2850/2855/2860

2870/2890

2851

Material Type	Part No.	A Dia.	B Current Part Height	C Part Height Capab.	Hub Dia.	Threaded Female Insert									Threaded Male Stud*									Threaded Female Insert Thru-Hole																									
						8-32	10-24	10-32	1/4-20	1/4-28	5/16-18	5/16-24	3/8-16	3/8-24	1-2/13	1/2-20	8-32	10-24	10-32	1/4-20	1/4-28	5/16-18	5/16-24	3/8-16	3/8-24	1-2/13	1/2-20	8-32	10-24	10-32	1/4-20	1/4-28	5/16-18	5/16-24	3/8-16	3/8-24	1-2/13	1/2-20											
TS	2850	1	7/8	.875-1.000	3/4	■	■	■	■	▲								■	■	■	■							■	■	■	■							■	■	■	■								
TS	2855	3/4	35/64, 5/8, 11/16	.547-.750	1/2	■	■	■	■	▲								■	■	■	■	▲						■	■	■	■								■	■	■	■	▲						
TS	2860	1 3/16	13/16	N/A	13/16	▲	▲	▲	▲	■	■	■	■	▲			▲	▲	▲	▲	▲	▲				▲	▲	▲	▲	▲								▲	▲	▲	▲	▲	▲						
TS	2870	1 5/8	7/8	N/A	1 5/32	▲	▲	▲	▲	■	■	■	■	▲			▲	▲	▲	▲	▲	▲				▲	▲	▲	▲	▲								▲	▲	▲	▲	▲	▲						
TS	2890	2 1/2	1 1/2	N/A	1 1/4	▲	▲	▲	▲	■	■	■	■	▲			▲	▲	▲	▲	▲	▲				▲	▲	▲	▲	▲								▲	▲	▲	▲	▲	▲						
TP	2851	1	7/8	.875-1.000	3/4	▲	▲	▲	▲	■	■	■	■	▲			▲	▲	▲	▲	▲	▲				▲	▲	▲	▲	▲								▲	▲	▲	▲	▲	▲						

\* For parts with male studs, LENGTH projecting below knob must be specified.  
 ■ Currently Manufacture/Tooled  
 ▲ Could Manufacture/Requires Tooling  
 TS Thermoset  
 TP Thermoplastic

# Four Lobe - Metric Sizes



Davies now offers metric four lobe knobs with standard inserts! These new knobs offer the same exceptional appearance as our four arm knobs and are part of a family that will provide a comfortable ergonomic grip.



2805



2821



2823



2829



2832



2841

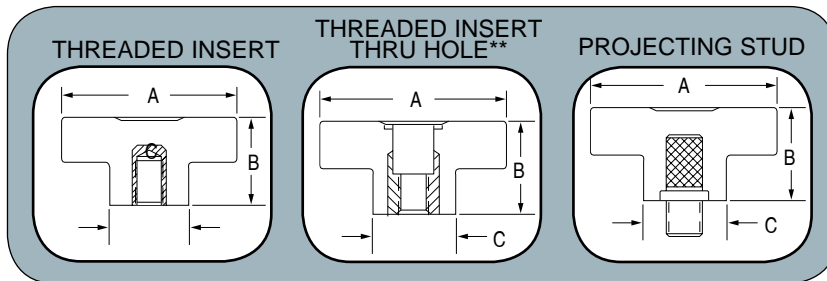

Material Type	Part No.	A Dia.	B Current Part Height	C Part Height Capab.	Hub Dia.	Threaded Female Insert								Threaded Male Stud*																										
						8-32	10-24	10-32	1/4-20	1/4-28	5/16-18	5/16-24	3/8-16	3/8-24	1-2/13	1/2-20	8-32	10-24	10-32	1/4-20	1/4-28	5/16-18	5/16-24	3/8-16	3/8-24	1-2/13	1/2-20													
TS	2805	25	16	NA	12				■																															
TS	2821	32	32	NA	14				■		■																													
TS	2823	40	25	NA	18				■		■		■																											
TS	2829	50	32	NA	22				■		■		■																											
TS	2832	63	40	NA	26						■		■		■																									
TS	2841	80	50	NA	35						■		■		■																									

\* For parts with male studs. LENGTH projecting below knob must be specified.

■ Currently Manufacture/Tooled

▲ Could Manufacture/Requires Tooling

TS Thermoset

TP Thermoplastic

\*\* Threaded Thru-Hole Available, Call for a quotation





# Seven Lobe - Metric Sizes

Davies now offers metric seven lobe knobs with standard inserts! These new knobs offer a comfortable ergonomic grip and provide exceptional strength and grip.

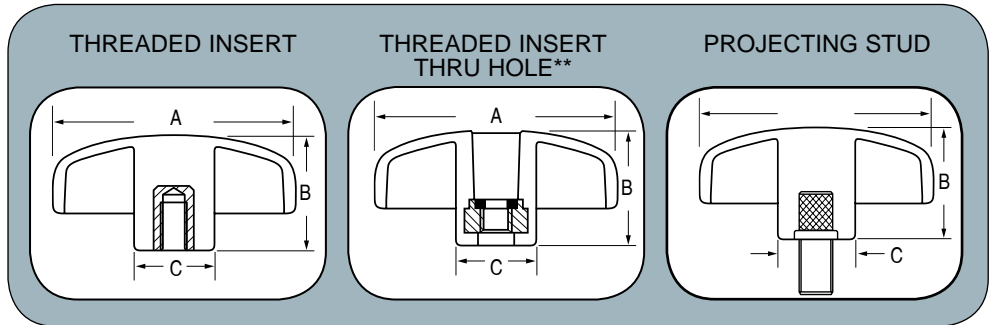

Material Type	Part No.	A				Threaded Female Insert												Threaded Male Stud*									
		Dia.	Current Part Height	Part Height Capab.	Hub Dia.	8-32	10-24	10-32	1/4-20	1/4-28	5/16-18	5/16-24	3/8-16	3/8-24	1-2/13	1/2-20	8-32	10-24	10-32	1/4-20	1/4-28	5/16-18	5/16-24	3/8-16	3/8-24	1-2/13	1/2-20
						8-32	10-24	10-32	1/4-20	1/4-28	5/16-18	5/16-24	3/8-16	3/8-24	1-2/13	1/2-20	8-32	10-24	10-32	1/4-20	1/4-28	5/16-18	5/16-24	3/8-16	3/8-24	1-2/13	1/2-20
TS	2968	25	16	NA	12				■											■							
TS	2972	32	32	NA	14				■		■									■		■					
TS	2974	40	25	NA	18				■		■		■							■		■		■			
TS	2978	50	32	NA	22				■		■		■							■		■		■			
TS	2983	63	40	NA	26						■		■		■						■		■		■		
TS	2988	80	50	NA	35						■		■		■						■		■		■		

\* For parts with male studs, LENGTH projecting below knob must be specified.  
 ■ Currently Manufacture/Tooled  
 ▲ Could Manufacture/Requires Tooling  
 TS Thermoset  
 TP Thermoplastic  
 \*\* Threaded Thru-Hole Available, Call for a quotation



# Fluted Clamping

We offer a variety of sizes to suit your clamping needs. High impact thermoplastic. Wide range of uses – pulls, feet, clamping, fine adjustments, etc. Can be decorated.

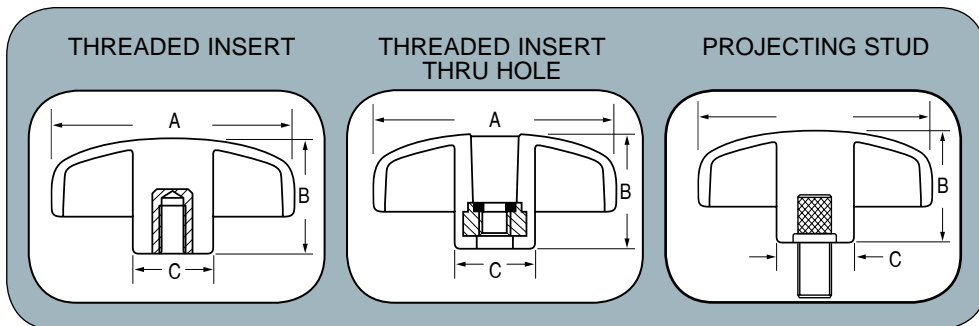

Material Type	Part No.	A Dia.	B Current Part Height	C Part Height Capab.	Hub Dia.	Threaded Female Insert												Threaded Male Stud*												Threaded Female Insert Thru-Hole											
						8-32	10-24	10-32	1/4-20	1/4-28	5/16-18	5/16-24	3/8-16	3/8-24	1-2/13	1/2-20	8-32	10-24	10-32	1/4-20	1/4-28	5/16-18	5/16-24	3/8-16	3/8-24	1-2/13	1/2-20	8-32	10-24	10-32	1/4-20	1/4-28	5/16-18	5/16-24	3/8-16	3/8-24	1-2/13	1/2-20			
TP	4300	2 1/2	1 5/32	N/A	13/16	■	▲	■	▲	■	▲	■	▲	■	▲	■	▲	■	▲	■	▲	■	▲	■	▲	■	▲	■	▲	■	▲	■	▲	■	▲	■	▲	■	▲		
TP	4302	2 1/2	1 5/32	N/A	13/16																				▲	■	■	■	■	■	■	■	■	■	■	■	■	■	■		
TP	4310	1 3/4	1	N/A	11/16	■	▲	■	▲	■	▲	■	▲	■	▲	■	▲	■	▲	■	▲	■	▲																		
TP	4312	1 3/4	1	N/A	11/16																			▲	■	■	■	■	■	■	■	■	■	■	■	■	■	■	■		
TP	4320	1 1/4	13/16	N/A	1/2	■	▲	■	▲	■	▲	■	▲	■	▲	■	▲	■	▲	■	▲	■	▲																		
TP	4322	1 1/4	13/16	N/A	1/2																			■	■	■	■	■	■	■	■	■	■	■	■	■	■	■	■		

\* For parts with male studs, LENGTH projecting below knob must be specified.  
 ■ Currently Manufacture/Tooled  
 ▲ Could Manufacture/Requires Tooling  
 TS Thermoset  
 TP Thermoplastic

CLAMPING KNOBS





# Knurled/Scalloped Clamping

Another solid family of phenolic utility knobs for mechanical and electric applications. Good heat resistance and durability. Engraving, hot stamping, and pad printing available for all parts.



3030/3080



3050/3055/3065

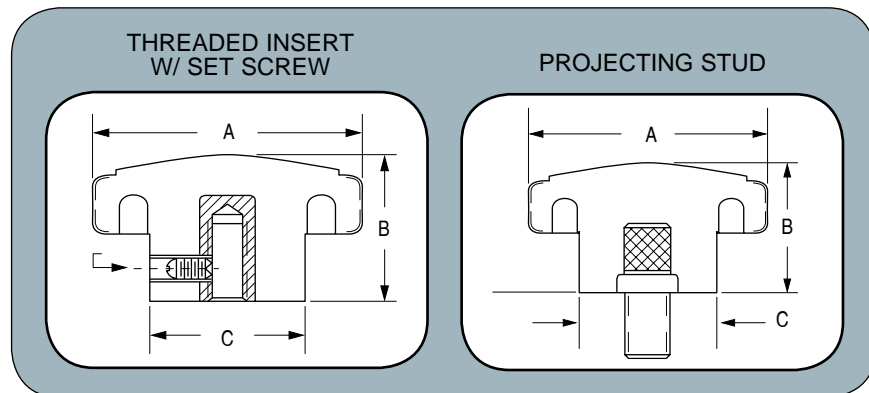

Material Type	Part No.	A Dia.	B Current Part Height	C Part Height Capab.	Hub Dia.	Threaded Female Insert								Threaded Male Stud*																
						8-32	10-24	10-32	1/4-20	1/4-28	5/16-18	5/16-24	3/8-16	3/8-24	1-2/13	1/2-20	8-32	10-24	10-32	1/4-20	1/4-28	5/16-18	5/16-24	3/8-16	3/8-24	1-2/13	1/2-20			
TS	3030	1 3/4	25/32, 1 1/32, 1 9/32, 1 1/4	.781-1.250	3/4	▲	■	■	■	■	■	■	■	■	■	■	■	■	■	■	■	■	■	■	■	■	■	■	▲	▲
TS	3050	1 3/4	15/16, 31/32, 1 1/4	.934-1.375	1	▲	■	■	■	▲	■	■	■	■	■	■	■	■	■	■	■	■	■	■	■	■	■	■	■	
TS	3055	1 1/4	3/4, 1 1/16	.750-1.250	3/4	▲	■	■	■	▲	■	■	■	■	■	■	■	■	■	■	■	■	■	■	■	■	■	▲	▲	
TS	3065	1	1/2, 9/16, 3/4, 1	.500-1.125	5/8	■	■	■	■	▲	■	■	■	■	■	■	■	■	■	■	■	■	■	■	■	■	■	■	■	
TS	3080	1 1/4	3/4, 7/8, 1 5/16	.750-1.375	5/8	▲	■	■	■	▲	■	■	■	■	■	■	■	■	■	■	■	■	■	■	■	■	■	■	■	

\* For parts with male studs. LENGTH projecting below knob must be specified.  
 ■ Currently Manufacture/Tooled  
 ▲ Could Manufacture/Requires Tooling  
 TS Thermoset  
 TP Thermoplastic

# Mini Clamping

Available with a wide flange female insert for positive contact, as in battery posts. Good electrical properties in small clamping knobs.

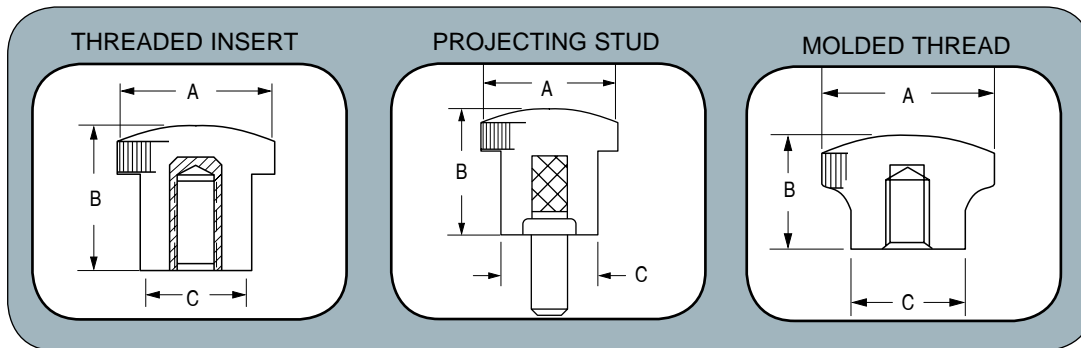

Material Type	Part No.	A Dia.	B Current Part Height	C Part Height Capab.	Hub Dia.	Threaded Female Insert				Threaded Male Stud*				Threaded Female Insert Thru-Hole										
						6-32	8-32	10-24	10-32	1/4-20	1/4-28	5/16-18	5/16-24	6-32	8-32	10-24	10-32	1/4-20	1/4-28	5/16-18	5/16-24			
TS	1770	31/64	1/2, 33/64, 5/8, 3/4, 7/8, 29/32	.500-906	3/8	■	■	▲	▲								■	■	▲	▲				
TS	2710	3/4	1/2, 33/64	N/A	1/2	▲	■	■	■	▲	▲						▲	■	■	■	▲	▲		
TS	2720	5/8	9/16	N/A	7/16	▲	■	■	■	▲	▲						▲	■	■	■	▲	▲		
TS	2730	13/16	33/64, 17/32	N/A	7/16	▲	▲	■	■	▲	▲						▲	▲	■	■	▲	▲		
TP	2700	9/16	1/2, 17/32, 35/64, 5/8	N/A	1/2	■	■	■	■	▲	▲	▲	▲	▲	▲	▲	■	■	■	■	▲	▲	▲	▲
TP	2715	45/64	35/64	N/A	7/16					▲	■	■	■	■	■									
TP	2745	9/16	9/16	N/A	1/2	■	■	▲	▲	▲	▲	▲	▲	▲	▲	▲	■	■	■	■	▲	▲	▲	▲
TP	7094	41/64	1/4, 17/32	.250-.562	29/64	▲	▲	▲	■	▲	▲	▲	▲	▲	▲		▲	▲	▲	■	▲	▲		

\* For parts with male studs. LENGTH projecting below knob must be specified.  
 ■ Currently Manufacture/Tooled  
 ▲ Could Manufacture/Requires Tooling  
 TS Thermoset  
 TP Thermoplastic



# Dominator

Our largest knob for serious clamping needs. Domed top or thru hole with exceptional strength. Attractive textured top. Shown in grey and black.



3340



3350



3370



3341



3351



3371

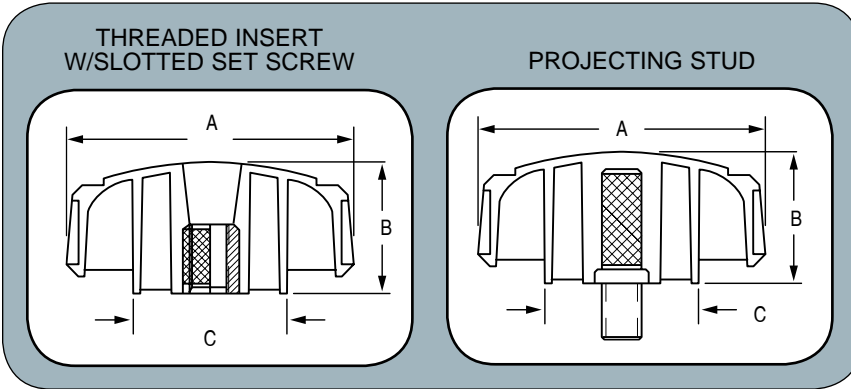

Material Type	Part No.	A Dia.	B Current Part Height	C Part Height Capab.	Hub Dia.	Threaded Female Insert					Threaded Male Stud*					Threaded Female Insert Thru-Hole																																
						8-32	10-24	10-32	1/4-20	1/4-28	5/16-18	5/16-24	3/8-16	3/8-24	1-2/13	1/2-20	8-32	10-24	10-32	1/4-20	1/4-28	5/16-18	5/16-24	3/8-16	3/8-24	1-2/13	1/2-20																					
TP	3340	1 7/8	53/64	N/A	1	▲	▲	▲	▲	▲	▲	▲	▲	▲	▲	▲	▲																															
TP	3341	1 7/8	53/64	N/A	1																				▲	▲	▲																					
TP	3350	2 9/16	1 1/8	N/A	1 3/8	▲	▲	▲	▲	▲	▲	▲	▲	▲	▲	▲	▲	▲	▲	▲	▲	▲	▲																									
TP	3351	2 9/16	1 1/8	N/A	1 3/8	▲	▲	▲	▲	▲	▲	▲	▲	▲	▲	▲	▲	▲	▲	▲	▲	▲	▲																									
TP	3370	3 23/32	1 21/32	N/A	2	▲	▲	▲	▲	▲	▲	▲	▲	▲	▲	▲	▲	▲	▲	▲	▲	▲	▲																									
TP	3371	3 23/32	1 21/32	N/A	2	▲	▲	▲	▲	▲	▲	▲	▲	▲	▲	▲	▲	▲	▲	▲	▲	▲	▲																									

\* For parts with male studs. LENGTH projecting below knob must be specified.

■ Currently Manufacture/Tooled  
▲ Could Manufacture/Requires Tooling  
TS Thermoset  
TP Thermoplastic



The lion of clamping knobs. Rock solid performance with a multitude of uses. Very comfortable handle. Can have an inlay added to provide identification, decorations, or instructions. Glossy finish. Engraving, hot stamping, and pad printing available for all parts.



4100/4101

4102

4103

with Pointer

Specify Part Numbers and Pointer Length				
"P" Length	Pointer Adaptable to			
	4100	4101	4102	4103
5/8	■			
3/4	■	■		
7/8	■	■	■	
1-1/16	■	■	■	■
1-3/16	■	■	■	■
1-1/4	■	■	■	■
1-9/16	■	■	■	■

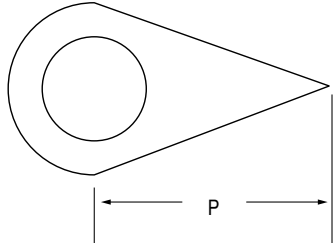

Pointer Information: Material: White vinylite, .040" thick. Assembly: Spun tight to brass insert. Specials: Available upon request.

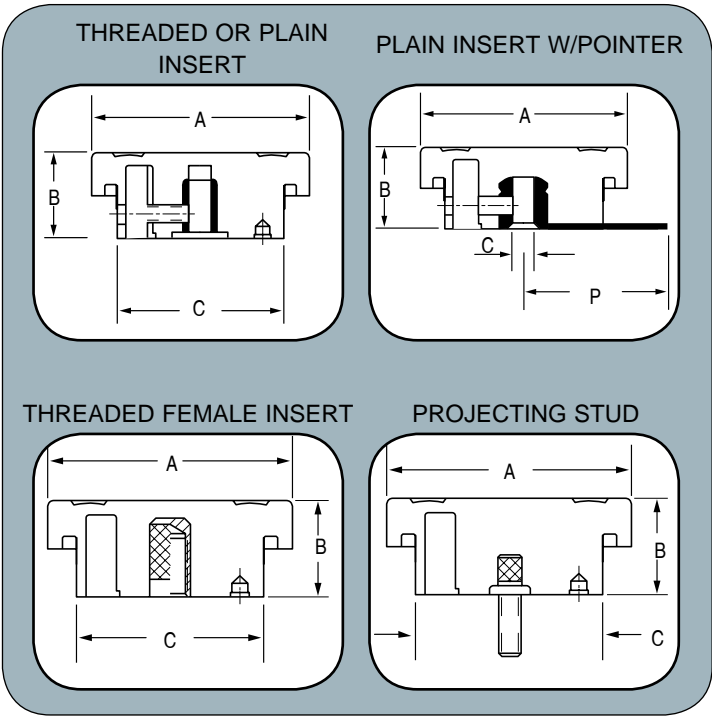

Material Type	Part No.	A Dia.	B Current Part Height	C Part Height Capab.	Hub Dia.	Threaded Female Insert											Threaded Male Stud*							Female Insert	Plain Molded Hole	Square Valve Stem											
						8-32	10-24	10-32	1/4-20	1/4-28	5/16-18	5/16-24	3/8-16	3/8-24	7/16-14	7/16-20	1-2/13	1-2/20	8-32	10-24	10-32	1/4-20	5/16-18	5/16-24	3/8-16		3/8-24	7/16-14	7/16-20	1-2/13	1-2/20	1/4	5/16	3/8	1/4	5/16	3/8
TS	4100	1 1/8	5/8	13/16	9/16	▲▲▲▲	▲▲▲▲	▲▲▲▲	▲▲▲▲	▲▲▲▲	▲▲▲▲	▲▲▲▲	▲▲▲▲	▲▲▲▲	▲▲▲▲	▲▲▲▲	▲▲▲▲	▲▲▲▲	▲▲▲▲	▲▲▲▲	▲▲▲▲	▲▲▲▲	▲▲▲▲	▲▲▲▲	▲▲▲▲	▲▲▲▲	▲▲▲▲	▲▲▲▲	▲▲▲▲	▲▲▲▲	▲▲▲▲	▲▲▲▲	▲▲▲▲	▲▲▲▲	▲▲▲▲	▲▲▲▲	▲▲▲▲
TS	4101	1 3/8	11/16	13/16	9/16	▲▲▲▲	▲▲▲▲	▲▲▲▲	▲▲▲▲	▲▲▲▲	▲▲▲▲	▲▲▲▲	▲▲▲▲	▲▲▲▲	▲▲▲▲	▲▲▲▲	▲▲▲▲	▲▲▲▲	▲▲▲▲	▲▲▲▲	▲▲▲▲	▲▲▲▲	▲▲▲▲	▲▲▲▲	▲▲▲▲	▲▲▲▲	▲▲▲▲	▲▲▲▲	▲▲▲▲	▲▲▲▲	▲▲▲▲	▲▲▲▲	▲▲▲▲	▲▲▲▲	▲▲▲▲	▲▲▲▲	▲▲▲▲
TS	4102	1 5/8	3/4	1 1/8	5/8	▲▲▲▲	▲▲▲▲	▲▲▲▲	▲▲▲▲	▲▲▲▲	▲▲▲▲	▲▲▲▲	▲▲▲▲	▲▲▲▲	▲▲▲▲	▲▲▲▲	▲▲▲▲	▲▲▲▲	▲▲▲▲	▲▲▲▲	▲▲▲▲	▲▲▲▲	▲▲▲▲	▲▲▲▲	▲▲▲▲	▲▲▲▲	▲▲▲▲	▲▲▲▲	▲▲▲▲	▲▲▲▲	▲▲▲▲	▲▲▲▲	▲▲▲▲	▲▲▲▲	▲▲▲▲	▲▲▲▲	▲▲▲▲
TS	4103	2 3/8	27/32	1 3/4	47/64	▲▲▲▲	▲▲▲▲	▲▲▲▲	▲▲▲▲	▲▲▲▲	▲▲▲▲	▲▲▲▲	▲▲▲▲	▲▲▲▲	▲▲▲▲	▲▲▲▲	▲▲▲▲	▲▲▲▲	▲▲▲▲	▲▲▲▲	▲▲▲▲	▲▲▲▲	▲▲▲▲	▲▲▲▲	▲▲▲▲	▲▲▲▲	▲▲▲▲	▲▲▲▲	▲▲▲▲	▲▲▲▲	▲▲▲▲	▲▲▲▲	▲▲▲▲	▲▲▲▲	▲▲▲▲	▲▲▲▲	▲▲▲▲

\* For parts with male studs. LENGTH projecting below knob must be specified.  
 ▲ Currently Manufacture/Tooled  
 ▲▲ Could Manufacture/Requires Tooling  
 TS Thermoset  
 TP Thermoplastic

# 2 Shot Soft Touch Control



Distinctive knobs for special applications. Available in a wide range of sizes and styles. Female insert, plain molded hole, spring mounting, and interference fit options.



Other 2-shot control knobs available in ABS, polypropylene, nylon, and other thermoplastic material for more demanding applications.



Popular colors include red, gray, blue, green, white, black, and yellow. We can color match for your application.

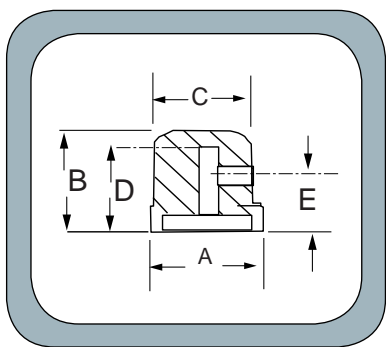

Material Type	Part No.	A	B	C	D	E	Molded Hole				Female Insert				Interference Fit				"D" Flat Spring Mount			
							1/8"	3/16"	1/4"	6mm	1/8"	3/16"	1/4"	6mm	1/8"	3/16"	1/4"	6mm	1/4" flat to 5/32"	6mm flat to 4.5mm		
TPO	1221	0.45	0.55	0.45	0.44	0.375	■	■	■	■					■	■	■	■	■	■	■	■
TPO	1226	0.60	0.85	0.60	0.60	0.375	■	■	■	■					■	■	■	■	■	■	■	■
TPO	1227	0.60	0.85	0.50	0.60	0.375	■	■	■	■					■	■	■	■	■	■	■	■
TPO	1230	0.72	0.70	0.72	0.60	0.375	■	■	■	■	■	■	■	■	■	■	■	■	■	■	■	■
TPO	1231	0.79	0.70	0.66	0.60	0.375	■	■	■	■	■	■	■	■	■	■	■	■	■	■	■	■

\* For parts with male studs. LENGTH projecting below knob must be specified.  
 ■ Currently Manufacture/Tooled  
 ▲ Could Manufacture/Requires Tooling  
 TPO Thermoplastic Overmold



# 2 and 3 Shot Soft Touch Control

2 Shot and 3 Shot knobs for special applications. Available in a wide range of sizes and styles.



1101



1104, set screw on side



1106



1107



1108



1109



1116



1117

## New! 3 Shot Soft Touch Control Knobs



1167



1168



1169

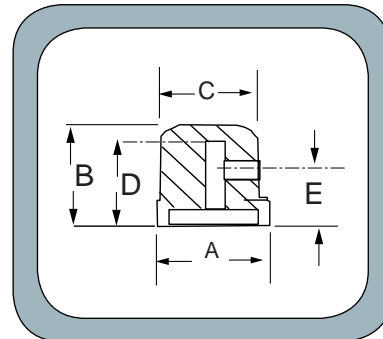

Material Type	Part No.	A	B	C	D	E	"D" Flat Spring Mount	Molded Spline Mount
TPO	1101	0.63	0.58	NA	0.48	NA	6 x 4.5 mm	6mm x18 teeth
TPO	1104	1.14	0.55	NA	0.49	NA		6mm**
TPO	1106	0.73	0.71	NA	0.66	NA	6 x 4.5 mm	6mm x18 teeth
TPO	1107	0.72	0.57	0.34	NA	NA	2.5 x 3.4 mm	
TPO	1108	0.48	0.57	0.34	NA	NA	6 x 4.5 mm	
TPO	1109	0.67	0.69	NA	0.56	NA	6 x 4.5 mm	6mm x18 teeth
TPO	1116	0.74	0.61	NA	0.51	NA		6mm x18 teeth
TPO	1117	0.57	0.58	0.66	0.53	NA	6 x 4.5 mm	6mm x18 teeth
TPO	1167	0.46	0.61	NA	0.51	NA		6mm x18 teeth
TPO	1168	0.58	0.64	NA	0.51	NA		6mm x18 teeth
TPO	1169	0.58	0.63	NA	0.54	NA		6mm x18 teeth

TPO Thermoplastic Overmold

\*\* Brass Bushing Insert Mount

# Collet Mount New!

Unique knobs with secure collet mounting for special applications. Available with or without a bottom nylon pointer. Base colors: Black(B) or Slate Gray(S) and Top/Pointer colors: black(B), red(R), slate gray(S), blue(L), green(G), or yellow(Y).



- Thermoplastic Material
- Indicator line is optional
- With nylon color inlay
- Collet Mount, set screw on top
- Brass Bushing insert

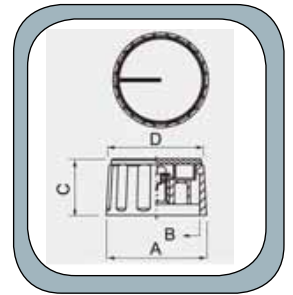

Material Type	A (mm)	B (mm)	C (mm)	D (mm)	Brass Insert Ø	Black Top	Blue Top	Slate Gray Top	Green Top	Red Top	Yellow Top
TP black	36.5	30	20.5	33	1/4"	1121-BB	1121-BL	1121-BS	1121-BG	1121-BR	1121-BY
TP gray	36.5	30	20.5	33	1/4"	1121-SB	1121-SL	1121-SB	1121-SG	1121-SR	1121-SY
TP black	28.5	23	19.5	25	1/4"	1122-BB	1122-BL	1122-BS	1122-BG	1122-BR	1122-BY
TP gray	28.5	23	19.5	25	1/4"	1122-SB	1122-SL	1122-SS	1122-SG	1122-SR	1122-SY
TP black	21.3	16	18.8	18.5	1/4"	1123-BB	1123-BL	1123-BS	1123-BG	1123-BR	1123-BY
TP gray	21.3	16	18.8	18.5	1/4"	1123-SB	1123-SL	1123-SS	1123-SG	1123-SR	1123-SY
TP black	15.3	NA	18	12.8	1/4"	1124-BB	1124-BL	1124-BS	1124-BG	1124-BR	1124-BY
TP gray	15.3	NA	18	12.8	1/4"	1124-SB	1124-SL	1124-SS	1124-SG	1124-SR	1124-SY
TP black	10	NA	15	8.1	1/8"	1125-BB	1125-BL	1125-BS	1125-BG	1125-BR	1125-BY
TP gray	10	NA	15	8.1	1/8"	1125-SB	1125-SL	1125-SS	1125-SG	1125-SR	1125-SY

# Collet Mount with Pointer New!



- Thermoplastic Material
- Indicator line is optional
- With nylon color inlay
- Collet Mount, set screw on top
- Brass Bushing insert
- With bottom nylon pointer

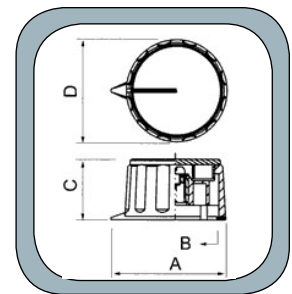

Material Type	A (mm)	B (mm)	C (mm)	D (mm)	Brass Insert Ø	Black Top	Blue Top	Slate Gray Top	Green Top	Red Top	Yellow Top
TP black	41.8	30	21.8	36.7	1/4"	1161-BB	1161-BL	1161-BS	1161-BG	1161-BR	1161-BY
TP gray	41.8	30	21.8	36.7	1/4"	1161-SB	1161-SL	1161-SB	1161-SG	1161-SR	1161-SY
TP black	33	23	21	28.7	1/4"	1162-BB	1162-BL	1162-BS	1162-BG	1162-BR	1162-BY
TP gray	33	23	21	28.7	1/4"	1162-SB	1162-SL	1162-SS	1162-SG	1162-SR	1162-SY
TP black	26	16	19.8	21.7	1/4"	1163-BB	1163-BL	1163-BS	1163-BG	1163-BR	1163-BY
TP gray	26	16	19.8	21.7	1/4"	1163-SB	1163-SL	1163-SS	1163-SG	1163-SR	1163-SY
TP black	18.5	NA	19.2	15.6	1/4"	1164-BB	1164-BL	1164-BS	1164-BG	1164-BR	1164-BY
TP gray	18.5	NA	19.2	15.6	1/4"	1164-SB	1164-SL	1164-SS	1164-SG	1164-SR	1164-SY
TP black	13.5	NA	15.8	10.5	1/8"	1165-BB	1165-BL	1165-BS	1165-BG	1165-BR	1165-BY
TP gray	13.5	NA	15.8	10.5	1/8"	1165-SB	1165-SL	1165-SS	1165-SG	1165-SR	1165-SY

# Instrument

Distinctive knobs for special applications. Glossy or satin finish. Phenolic for durability and attractive appearance. Line or slot for indicating a setting.



1100



1105



1110



1120



1140



1145



1150



1155

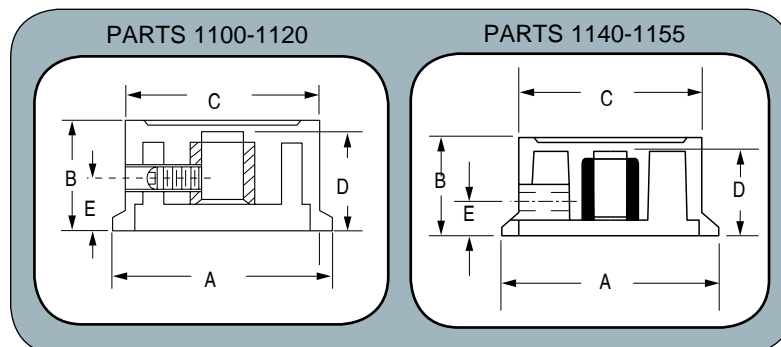

Material Type	Part No.	A	B	C	D	E
TS	1100	25/32	15/32	21/32	13/32	1/2
TS	1105	1	37/64	29/32	1/2	27/32
TS	1110	1 9/32	21/32	1 5/32	33/64	1 1/32
TS	1120	1 3/4	13/16	1 1/2	45/64	1 15/32
TS	1140	19/32	35/64	31/64	27/64	23/64
TS	1145	13/16	5/8	41/64	1/2	1/2
TS	1150	15/16	25/32	3/4	19/32	19/32
TS	1155	1 3/8	45/64	1 9/64	19/32	29/32

Note: All parts include 1/4" brass insert with set screw.  
 \* For parts with male studs. LENGTH projecting below knob must be specified.  
 ■ Currently Manufacture/Tooled  
 ▲ Could Manufacture/Requires Tooling  
 TS Thermoset  
 TP Thermoplastic

# Instrument

Fine ABS control knobs. Sophisticated, low profile appearance, combined with high quality function. Inlay and imprinting available on all parts.



8070



8090



8125/8175



8225



8450



8460

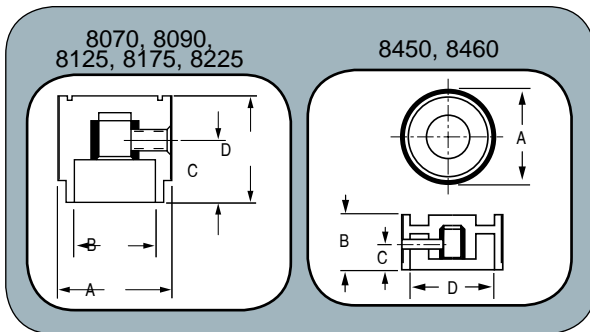

Material Type	Part No.	A	B	C	D	Plain Molded Hole			Female Insert			Spring Mounting
						1/8	3/16	1/4	1/8	3/16	1/4	1/4 Flatted to 5/32
TP	8070	23/32	1/2	13/32	5/8	▲	▲	▲	▲	▲	■	▲
TP	8090	29/32	27/32	11/16	21/32	▲	▲	■	▲	▲	■	■
TP	8125	1 1/4	11/16	17/32	1 3/64	▲	▲	■	▲	▲	■	■
TP	8175	1 3/4	7/8	21/32	1 15/32	▲	▲	▲	▲	▲	■	■
TP	8225	2 1/4	7/8	21/32	1 61/64	▲	▲	▲	▲	▲	■	■
TP	8450	1 1/2	27/32	5/8	1 5/16	▲	▲	▲	▲	▲	■	▲
TP	8460	2 1/8	27/32	11/16	1 55/64	▲	▲	▲	▲	▲	■	▲

Note: All parts can be supplied with or without set screw.  
 \* For parts with male studs, LENGTH projecting below knob must be specified.  
 ■ Currently Manufacture/Tooled  
 ▲ Could Manufacture/Requires Tooling  
 TS Thermoset  
 TP Thermoplastic

# Instrument

Terrific range of sizes and styles to suit your needs. Available in both thermoplastic and phenolic materials. Can be customized to your needs with decorative inlays, indicator lines, or slots. Engraving, hot stamping, and pad printing available.

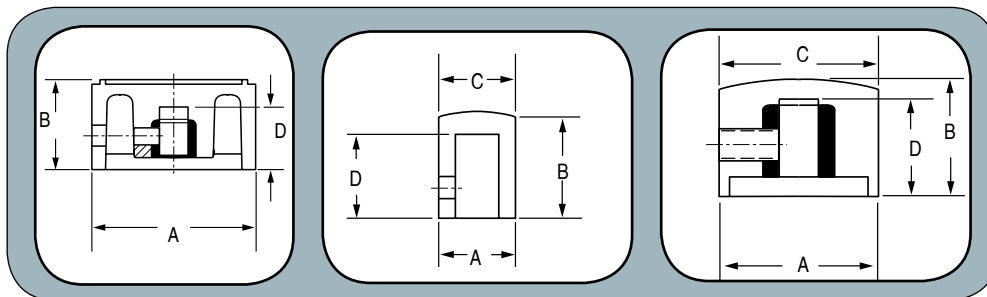

Material Type	Part No.	A	B	C	D	E	Plain Molded Hole			Female Insert			Spring Mounting
							1/8	3/16	1/4	1/8	3/16	1/4	1/4 Flatted to 5/32
TS	1200	17/32	5/8	-	7/16	-	■	■	■	▲	▲	▲	■
TS	1202	25/32	5/8	21/32	17/32	-	■	■	■	■	■	■	■
TS	1204	1 1/32	11/16	11/16	17/32	-	■	■	■	■	■	■	■
TS	1206	1 13/32	3/4	5/8	17/32	-	▲	▲	■	▲	▲	■	▲
TS	1208	1 25/32	13/16	5/8	17/32	-	▲	▲	■	▲	▲	■	■
TS	1450	11/16	13/32	11/32	-	-	■	■	■	■	▲	■	■
TS	1475	1	1/2	7/16	11/16	-	▲	▲	■	■	■	■	■
TS	1700	3/4	19/32	15/32	-	-	■	■	■	▲	▲	■	■
TS	1900	1/2	5/8	15/32	1/2	-	■	■	■	▲	▲	■	▲
TS	1914	3/4	31/64	3/4	13/32	5/8	■	■	■	■	■	■	▲
TS	1922	1 1/16	23/32	31/32	THRU	11/16	▲	▲	■	▲	▲	■	▲

\* For parts with male studs. LENGTH projecting below knob must be specified.

- Currently Manufacture/Tooled
- ▲ Could Manufacture/Requires Tooling
- TS Thermoset
- TP Thermoplastic

# Pointer

There is no larger selection of pointer knobs available anywhere. We carry the widest range of sizes, shapes, and inserts. Can be imprinted. Samples available.

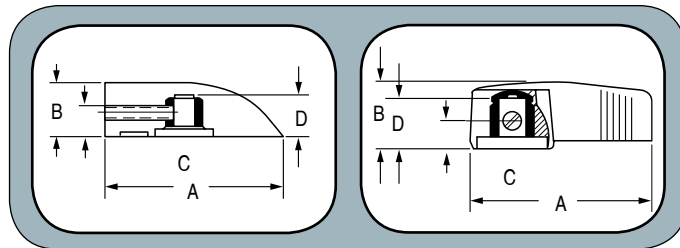

Material Type	Part No.	A	B	C	D	Plain Molded Hole			Female Insert			Spring Mounting 1/4 flatted to 5/32	Molded Spline Mount 6mm x 18 teeth
						1/8	3/16	1/4	1/8	3/16	1/4		
TS	0110	2 3/16	25/32	-	-	▲	▲	▲	▲	▲	■	▲	
TS	0112	1 3/4	5/8	-	1	▲	▲	▲	▲	▲	■	▲	
TS	0115	1 1/4	9/16	-	5/8	▲	▲	▲	▲	▲	■	▲	
TP	1118	0.77	0.64	0.66	0.54								■
TP	1119	1	0.65	0.85	0.55								■
TS	1210	1 1/32	5/8	21/32	17/32	■	■	■	■	■	■	■	
TS	1214	1 21/32	5/8	21/32	17/32	■	■	■	■	■	■	■	
TS	1216	1 9/32	5/8	21/32	17/32	■	■	■	■	■	■	■	
TS	1400	27/32	13/32	11/32	-	■	■	■	■	▲	■	■	
TS	1470	1 1/8	1/2	7/16	11/16	▲	■	■	■	■	■	■	
TS	1500	1 1/8	9/16	1/2	11/16	■	■	■	▲			▲	
TS	1510	3/4	9/16	13/32	9/16	■	■	■	▲			▲	
TS	1520	1 1/2	3/4	5/8	13/16	▲	▲	■	▲	▲	■	■	
TS	1550	1 1/8	5/8	7/16	11/16	■	▲	■	▲	▲	■	■	
TS	1919	1 1/4	5/8	-	1/2	▲	▲	■	▲	▲	■	▲	

\* For parts with male studs. LENGTH projecting below knob must be specified.

■ Currently Manufacture/Tooled  
▲ Could Manufacture/Requires Tooling  
TS Thermoset  
TP Thermoplastic



# Pointer

Davies offers the widest range of pointer knobs available from crisp lines to soft contours, choose a finish, shape, or design that complements your product. Engraving, hot stamping, pad printing available for all parts.

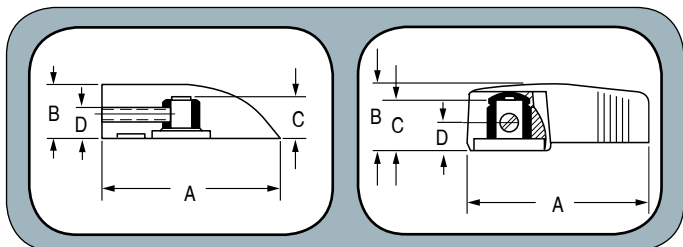

Material Type	Part No.	A	B	C	D	Plain Molded Hole			Female Insert			Spring Mounting
						1/8	3/16	1/4	1/8	3/16	1/4	1/4 Flatted to 5/32
TS	2100	2 1/2	5/8	7/16	5/8	▲	▲	▲	▲	▲	■	▲
TS	2110	1 5/8	39/64	7/16	5/8	▲	▲	■	▲	▲	■	▲
TS	2150	1 1/4	9/16	1/2	5/8	▲	▲	■	▲	▲		▲
TS	2300	1 7/32	5/8	1/2	21/32	▲	▲	■	▲	▲	■	▲
TS	2310	1 3/16	1/2	7/16	-	■	▲	■	▲	▲		▲
TS	2350	2	5/8	15/32	21/32	▲	▲	■	▲	▲	■	■
TP	1555	1 19/64	1/2	15/64	35/64	▲	▲	▲	▲			■
TP	1560	1 3/4	21/32	35/64	5/8	▲	▲	▲	▲	▲		■
TP	8000	3/4	21/32	15/32	3/8	▲	▲	▲	■	▲		▲
TP	8005	1 3/64	25/32	21/32	9/16	▲	▲	▲	▲	▲	■	▲
TP	8010	1 3/8	1	7/8	11/16	▲	▲	▲	▲	▲	■	▲

\* For parts with male studs. LENGTH projecting below knob must be specified.

■ Currently Manufacture/Tooled  
 ▲ Could Manufacture/Requires Tooling  
 TS Thermoset  
 TP Thermoplastic

# Skirted

Sizes, shapes, decorative inlays, and graphics to enhance your products. Phenolic/nylon to provide appearance, strength, and heat resistance for a variety of applications. Engraving, hot stamping, and pad printing available for all parts.

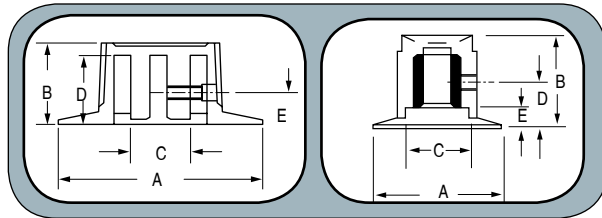

Material Type	Part No.	A	B	C	D	E	Plain Molded Hole			Female Insert			Spring Mounting
							1/8	3/16	1/4	1/8	3/16	1/4	1/4 Flatted to 5/32
TPO	1504	1	39/64	1/2	-	-	▲	▲	■	▲	▲	■	■
TPO	1505	1 3/8	27/32	1/2	-	-	▲	▲	■	▲	▲	■	■
TPO	1506	1 5/8	61/64	1/2	-	-	▲	▲	■	▲	▲	■	■
TS	1212	1 1/8	11/16	21/32	17/32	1/2	▲	▲	■	▲	▲	■	■
TS	1322	1 7/16	9/16	11/16	-	-	▲	▲	■	▲	▲	▲	▲
TS	1326	1 59/64	1/2	7/8	-	-	▲	▲	■	▲	▲	▲	▲
TS	1330	2 1/2	43/64	1 21/64	-	-	▲	▲	■	▲	▲	▲	▲
TS	1600	1 1/2	11/16	5/8	-	-	▲	▲	■	▲	▲	■	■
TS	1610	29/32	19/32	19/32	-	-	■	▲	■	▲	▲	■	■
TS	1650	2 1/4	7/8	1	-	-	▲	▲	■	▲	▲	▲	▲
TS	1910	3/4	1/2	17/32	13/32	9/16	■	■	■	■	■	■	■
TS	1913	1 1/8	5/8	13/16	1/2	11/16	▲	▲	■	▲	▲	■	■
TS	1920	1 1/4	3/4	31/32	19/32	11/16	▲	▲	■	▲	▲	■	■
TS	1925	1 1/4	23/32	31/32	THRU	11/16	▲	▲	■	▲	▲	■	■
TS	1930	1 1/2	7/8	1 1/64	3/4	13/16	▲	▲	■	▲	▲	■	▲
TS	1940	2 1/32	15/16	1 3/8	13/16	13/16	▲	▲	■	▲	▲	■	■
TP	1620	1 1/4	5/8	15/32	-	-							■
TP	1630	1 9/16	49/64	15/32	-	-							■
TP	1640	1 3/4	7/8	15/32	-	-							■
TP	1660	1 5/8	27/32, 57/64, 61/64, 1 11/32, 2 5/32	1/2	-	-	▲	▲	▲	▲	▲	▲	▲
TP	1665	1 15/16	1 29/64, 1 3/4	5/8	-	-	▲	▲	▲	▲	▲	▲	▲
TP	1680	2	1 13/16	1/2	-	-	▲	▲	▲	▲	▲	▲	▲
TP	8072	1 1/8	13/16	11/16	9/16	-	▲	▲	▲	▲	▲	■	■

\* For parts with male studs, LENGTH projecting below knob must be specified.  
 ■ Currently Manufacture/Tooled  
 ▲ Could Manufacture/Requires Tooling  
 TS Thermoset  
 TP Thermoplastic  
 TPO Thermoplastic overmold

# Large Fluted with Skirts

Versatile knobs with mechanically attached skirts that will remain firmly in place. Skirts can be lined in white, as a location finder, or numbered to your specifications. Engraving, hot stamping, and pad printing available for all parts.



4104



4105



4106



4107



4108



4109

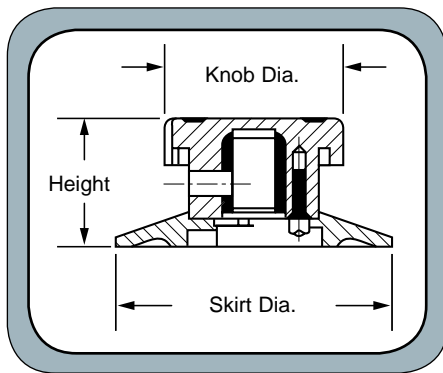

Material Type	Part No.	Knob	Skirt	Knob Diameter	Skirt Diameter	Combined Height	Female Insert				Plain Molded Hole			
							3/16	1/4	5/16	3/8	3/16	1/4	5/16	3/8
TS	4104	4100	4110	1 1/8	1 1/2	13/16	▲	■	▲	▲	▲	■	▲	▲
TS	4105	4100	4111	1 1/8	1 3/4	13/16	▲	■	▲	▲	▲	■	▲	▲
TS	4106	4101	4110	1 3/8	1 1/2	7/8	▲	■	▲	▲	▲	▲	▲	▲
TS	4107	4101	4111	1 3/8	1 3/4	7/8	▲	■	▲	▲	▲	▲	▲	▲
TS	4108	4102	4112	1 5/8	2 1/16	29/32	▲	■	▲	■	▲	■	▲	▲
TS	4109	4103	4113	2 3/8	3	1 1/32	▲	■	▲	■	▲	■	▲	▲

■ Currently Manufacture/Tooled  
 ▲ Could Manufacture/Requires Tooling  
 TS Thermoset  
 TP Thermoplastic

# Special Shapes and Sizes

These parts were designed for the customer who has a unique requirement in mind, whether it be size, shape, or mounting. If you don't find it here, send us a sketch of your needs.

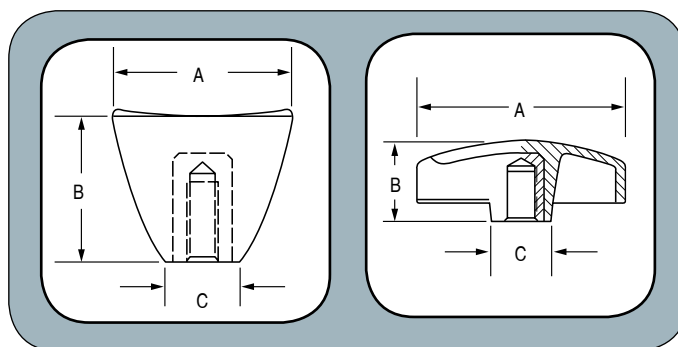

Material Type	Part No.	A Dia.	B Current Part Height	Part Height Capab.	C Hub Dia.	Threaded Female Insert							Threaded Male Stud*							Female Insert				Plain Molded Hole									
						8-32	10-24	10-32	1/4-20	1/4-28	5/16-18	5/16-24	3/8-16	3/8-24	1-2/13	1/2-20	8-32	10-24	10-32	1/4-20	1/4-28	5/16-18	5/16-24	3/8-16	3/8-24	1/4	5/16	3/8	7/16	1/2	1/4	5/16	3/8
TS	0099	3 7/16	7/8, 1, 1 1/32, 1 1/16, 1 1/2, 1 9/16	.875-1.625	1 1/8	▲	▲	▲	▲	▲	▲	▲	▲	▲	▲	▲	▲	▲	▲	▲	▲	▲	▲	▲	▲	▲	▲	▲	▲	▲	▲	▲	▲
TS	0125	3 1/2	1, 1 1/2	N/A	1 1/8	▲	▲	▲	▲	▲	▲	▲	▲	▲	▲	▲	▲	▲	▲	▲	▲	▲	▲	▲	▲	▲	▲	▲	▲	▲	▲	▲	▲
TS	2880	2 1/8	13/16	N/A	5/8	▲	▲	▲	▲	▲	▲	▲	▲	▲	▲	▲	▲	▲	▲	▲	▲	▲	▲	▲	▲	▲	▲	▲	▲	▲	▲	▲	▲
TS	0699	15/16	3 3/16	N/A	3/4	7/32 OR 3/8 DIA. THRU HOLE																											
TS	1775	-	19/32	N/A	-	RECTANGULAR FRICTION FIT FOR USE ON FLAT WIRE SHAFT																											
TS	4075	2 1/16	7/32	N/A	-	FINGER GUARD																											
TS	5149	-	51/64	N/A	-	SELF LOCATING FIT FOR USE ON FLAT WIRE SHAFT																											

\*For parts with male studs. LENGTH projecting below knob must be specified.  
 ■ Currently Manufacture/Tooled  
 ▲ Could Manufacture/Requires Tooling  
 TS Thermoset  
 TP Thermoplastic





# Thermoplastic Ball

Quality ball knobs made of polypropylene with a brass insert. Available in Red and Black.

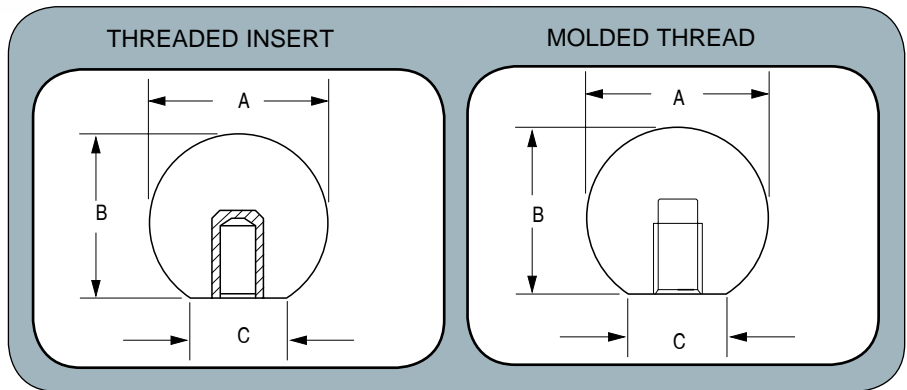

Material Type	Part No.	A Dia.	B Current Part Heights	C Hub Dia.	Threaded Female Insert												Threaded Male Stud*												Molded/Tapped Threads																
					8-32	10-24	10-32	1/4-20	1/4-28	5/16-18	5/16-24	3/8-16	3/8-24	1-2/13	1/2-20	5/8-11	5/8-18	8-32	10-24	10-32	1/4-20	1/4-28	5/16-18	5/16-24	3/8-16	3/8-24	1-2/13	1/2-20	5/8-11	5/8-18	8-32	10-24	10-32	1/4-20	1/4-28	5/16-18	5/16-24	3/8-16	3/8-24	1-2/13	1/2-20	5/8-11	5/8-18		
TP	0012	1	15/16	1/2	▲	▲	▲	▲	▲	▲	▲	▲	▲	▲					▲	▲	▲	▲	▲	▲	▲					▲	▲	▲	▲	▲	▲	▲	▲								
	w/shank	1	1	1/2	▲	▲	▲	▲	▲	▲	▲	▲	▲	▲					▲	▲	▲	▲	▲	▲	▲	▲					▲	▲	▲	▲	▲	▲	▲	▲							
TP	0013	1 3/16	1 5/64	11/16	▲	▲	▲	▲	▲	▲	▲	▲	▲	▲					▲	▲	▲	▲	▲	▲	▲	▲					▲	▲	▲	▲	▲	▲	▲	▲							
TP	0014	1 1/4	1 1/8	3/4	▲	▲	▲	▲	▲	▲	▲	▲	▲	▲					▲	▲	▲	▲	▲	▲	▲	▲					▲	▲	▲	▲	▲	▲	▲	▲							
TP	0016	1 3/8	1 1/4	3/4	▲	▲	▲	▲	▲	▲	▲	▲	▲	▲					▲	▲	▲	▲	▲	▲	▲	▲					▲	▲	▲	▲	▲	▲	▲	▲							
TP	0017	1 9/16	1 15/32	3/4	▲	▲	▲	▲	▲	▲	▲	▲	▲	▲					▲	▲	▲	▲	▲	▲	▲	▲					▲	▲	▲	▲	▲	▲	▲	▲							
TP	0018	1 1/2	1 13/32	3/4	▲	▲	▲	▲	▲	▲	▲	▲	▲	▲					▲	▲	▲	▲	▲	▲	▲	▲					▲	▲	▲	▲	▲	▲	▲	▲							
TP	0019	1 7/8	1 51/64	3/4	▲	▲	▲	▲	▲	▲	▲	▲	▲	▲					▲	▲	▲	▲	▲	▲	▲	▲					▲	▲	▲	▲	▲	▲	▲	▲							

\* For parts with male studs, LENGTH projecting below knob must be specified.  
 ■ Currently Manufacture/Tooled  
 ▲ Could Manufacture/Requires Tooling  
 TS Thermoset  
 TP Thermoplastic

















# Two Point/ Pull

Various models available in heat resistant phenolic, high impact strength thermoplastic, or soft touch thermoplastic elastomer overmold for a wide range of applications. May be anchored from top or bottom. If you don't see what you need, call us for additional models and styles.



Material Type	Part No.	A	B	Handle Width C	D	Female Insert					Tapped Thread					Plain Molded Hole		
						8-32	10-24	10-32	1/4-20	1/4-28	8-32	10-24	10-32	1/4-20	1/4-28	9/64	1/4	9/32
TS	4500	4 1/4	1 1/16	5/8	2 7/8						■	■	▲	▲	▲	■	▲	
TS	4560	5 1/2	1 3/4	1	4 1/4	▲	▲	▲	■	▲	▲	▲	▲	▲	▲	▲	▲	■
TS	5451	4 1/2	1 15/16	1	3 3/8	▲	▲	▲	▲	▲	▲	▲	▲	▲	▲	■	▲	▲
TP	4555	4 1/2	1 7/16	3/4	3 3/4	▲	■	■	■	▲	▲	▲	▲	▲	▲	■	▲	▲
TPO	4570	5 3/4	1 21/32	1 1/8	4 23/32	▲	▲	▲	▲	▲	▲	▲	▲	▲	▲	▲	■	
TP	4580	5 15/64	1 7/16	3/4	4 19/32	▲	■	■	■	▲	▲	▲	▲	▲	▲	■	▲	▲
TP	4590	7 27/32	1 7/16	3/4	7	▲	■	■	■	▲	▲	▲	▲	▲	▲			

- Currently Manufacture/Tooled
- ▲ Could Manufacture/Requires Tooling
- TS Thermoset
- TP Thermoplastic
- TPO ThermoplasticElastomer Overmold

# Two Point/ Pull

Modern industrial design for the highest demands. Extremely resistant to torsion and easy to grip. Glass bead reinforced, nylon, matte black finish or orange satin finish. Includes black oxide hexagon head cap screws with hexagon sockets DIN 912, zinc plated nuts DIN 934, and washers DIN 125. Available with stainless steel screws, nuts, and washers for wet areas. Also available without screws.

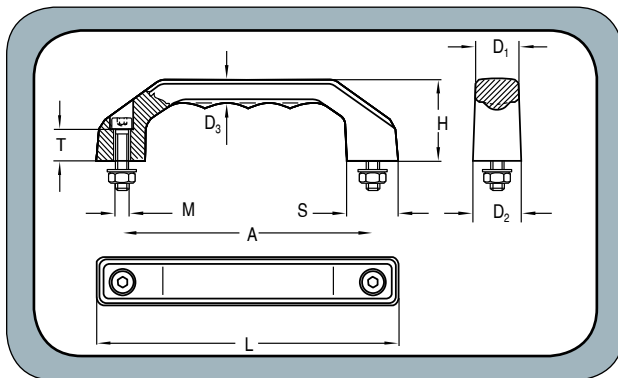

A	Color	Standard Order No.	Stainless Steel Hardware Order No.	Without Screws Order No.	M	T	L	H	D1	D2	D3	S
100	Black Orange	RG-1S.100.84 RG-1S.100.09	RG-1N.100.84 RG-1N.100.09	RG-1P.100.84 RG-1P.100.09	M 5 x 22	13	122	33	17	19	8.5	20
120	Black Orange	RG-1S.120.84 RG-1S.120.09	RG-1N.120.84 RG-1N.120.09	RG-1P.120.84 RG-1P.120.09	M 6 x 25	15	146	39	20.5	23	10.5	24
140	Black Orange	RG-1S.140.84 RG-1S.140.09	RG-1N.140.84 RG-1N.140.09	RG-1P.140.84 RG-1P.140.09	M 8 x 30	16	170	45	24	27	12	28
160	Black Orange	RG-1S.160.84 RG-1S.160.09	RG-1N.160.84 RG-1N.160.09	RG-1P.160.84 RG-1P.160.09	M 8 x 35	20	194	52	27.5	31	13.5	32
180	Black Orange	RG-1S.180.84 RG-1S.180.09	RG-1N.180.84 RG-1N.180.09	RG-1P.180.84 RG-1P.180.09	M 10 x 40	20	218	58	31	35	15.5	36
150	Black	GS-0S.150.7012	GS-0N.150.7012	GS-0P.150.7012	M 8 x 30	NA	178	53	25.5	29	NA	NA

All dimensions in metric

# Ratchet

Plastic levers have a glass-filled nylon with a built-in torquing mechanism, which makes this lever ideal for medium torque applications. The Die-Cast levers are made of zinc, and include black finish handles with a steel torquing mechanism.



Glass-Filled Nylon  
2430/2440/2450/2470/2480

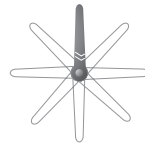

Lift and rotate  
handle 360°



Die-Cast  
2432/2442/2452/2472/2482

### "G" Standard Projecting Stud Lengths

Thread Size	Stud Lengths
10-24	0.63
10-32	0.63, 1.25
1/4-20	0.78, 0.98, 1.25, 1.57
5/16-18	0.78, 1.57, 1.97, 2.48
3/8-16	0.78, 1.25, 1.57, 1.97
1/2-13	1.25, 1.57, 1.97, 2.48
5/8-11	1.57, 2.48

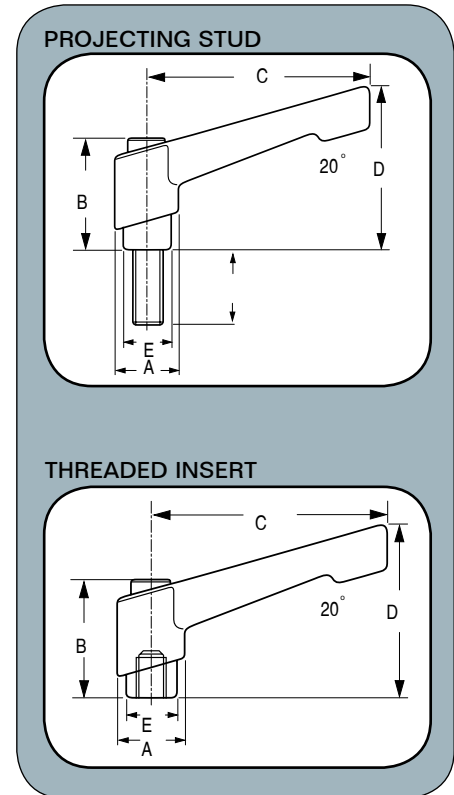

Material Type	Part No.	A	B	C	D	E	Threaded Female Insert						Threaded Male Stud*																													
							8-32	10-24	10-32	1/4-20	1/4-28	5/16-18	5/16-24	3/8-16	3/8-24	1-2/13	1/2-20	5/8-11	8-32	10-24	10-32	1/4-20	1/4-28	5/16-18	5/16-24	3/8-16	3/8-24	1-2/13	1/2-20	5/8-11												
TP	2430	35/64	61/64	1 21/32	1 19/64	25/64		■	■	■								■	■	■																						
TP	2440	23/32	1 7/32	2 9/16	1 25/32	17/32				■	■								■		■		■																			
TP	2450	55/64	1 13/32	3 5/64	2 1/8	5/8							■																													
TP	2470	63/64	1 11/16	3 5/8	2 33/64	3/4																																				
TP	2480	1 3/16	1 63/64	4 1/4	2 61/64	29/32																																				
DC	2432	35/64	61/64	1 21/32	1 19/64	25/64		■	■	■																																
DC	2442	23/32	1 7/32	2 9/16	1 25/32	17/32				■	■																															
DC	2452	55/64	1 13/32	3 5/64	2 1/8	5/8							■																													
DC	2472	63/64	1 11/16	3 5/8	2 33/64	3/4																																				
DC	2482	1 3/16	1 63/64	4 1/4	2 61/64	29/32																																				

\* For parts with male studs. LENGTH projecting below knob must be specified.  
 ■ Currently Manufacture/Tooled  
 ▲ Could Manufacture/Requires Tooling  
 TS Thermoset  
 TP Thermoplastic  
 DC Die-cast



# Adjustable

## "G" Standard Projecting Stud Lengths

Thread Size	Stud Lengths
10-32	0.39, 0.79
1/4-20	0.59, 0.79, 1.18
5/16-18	0.59, 0.79, 1.18, 1.57
3/8-16	0.79, 1.18, 1.57, 1.97
1/2-13	1.18, 1.97

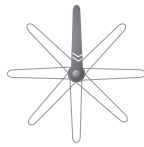

Lift and rotate handle 360

Glass-filled nylon handle with nylon torque mechanism. Insert is made of steel, zinc plated. Ideal for low torque applications.



2435

2445

2465

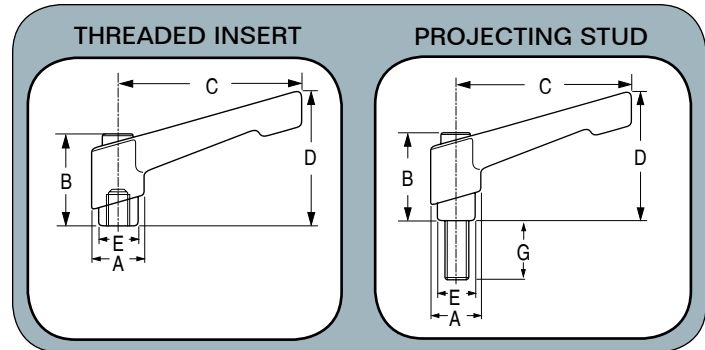

Material Type	Part No.	A	B	C	D	E	Threaded Female Insert						Threaded Male Stud*																			
							8-32	10-24	10-32	1/4-20	1/4-28	5/16-18	5/16-24	3/8-16	3/8-24	1-2/13	8-32	10-24	10-32	1/4-20	1/4-28	5/16-18	5/16-24	3/8-16	3/8-24	1-2/13						
TP	2435	5/8	1 3/64	1 21/32	1 3/8	15/32			■	■	■																					
TP	2445	51/64	1 27/64	2 9/16	1 31/32	19/32				■		■												■								
TP	2465	63/64	1 13/16	3 5/32	2 31/64	51/64								■	■				■												■	■

\* For parts with male studs. LENGTH projecting below knob must be specified.  
 ■ Currently Manufacture/Tooled  
 ▲ Could Manufacture/Requires Tooling  
 TP Thermoplastic

# Fixed Position

For multi-position clamping jobs. Great for limited space applications. Good leverage for tightening. Used on multiple types of equipment, doors, tools, etc. for a savings.



2405

2415

2425

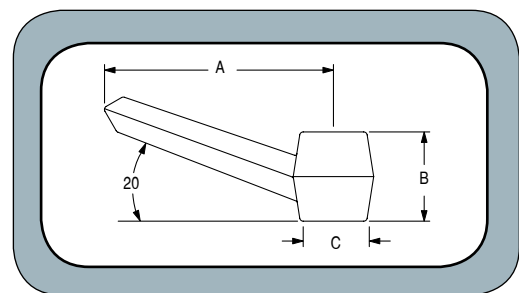

Material Type	Part No.	A	B	C	Threaded Female Insert						Threaded Male Stud*																					
					8-32	10-24	10-32	1/4-20	1/4-28	5/16-18	5/16-24	3/8-16	3/8-24	1-2/13	8-32	10-24	10-32	1/4-20	1/4-28	5/16-18	5/16-24	3/8-16										
TP	2405	2 1/16	51/64	19/32				■	■		■																					
TP	2415	2 5/8	1	13/16					■																		■					
TP	2425	3 5/32	1 9/32	15/16							■																					■

\* For parts with male studs. LENGTH projecting below knob must be specified.  
 ■ Currently Manufacture/Tooled  
 ▲ Could Manufacture/Requires Tooling  
 TP Thermoplastic

# Appliance

Available in heat resistant phenolic for high heat applications. This standard line of handles has been successfully used for pots, pans and many other applications. These handles represent a low cost option to get your product to the market quickly.

635	680
4-53/64" LONG HANDLE Rectangular Shaped 1/4" dia. Thru Hole with Counter Bore	4-1/2" LONG X 15/16" WIDE Mounting Hole: 13/64" or 9/32"
660	5682
4-1/2" LONG X 15/16" WIDE Mounting Hole: 13/64" or 9/32"	5-1/2" LONG Mounting Hole: 1/4" dia. Thru Hole with Counter Bore
670	
6-7/32" LONG X 1-3/16" WIDE 12° Tapered Face Mounting Recess for Weld Studs	



Material Type	Part No.	A	B	C	Plain Molded Hole				
					9/64	5/32	13/64	1/4	9/32
TS	0635	4 53/64	1	1 1/4	▲	▲	▲	■	▲
TS	0660	4 1/2	31/32	57/64	▲	▲	■	■	■
TS	0670	6 7/32	1 1/16	1 3/16	▲	▲	▲	■	▲
TS	0680	5 9/16	7/8	1	▲	▲	■	▲	■
TS	5682	5 1/2	1 5/32	-	▲	▲	▲	▲	■

\* For parts with male studs. LENGTH projecting below knob must be specified.  
 ■ Currently Manufacture/Tooled  
 ▲ Could Manufacture/Requires Tooling  
 TS Thermoset  
 TP Thermoplastic

These handles all can be made in a heat resistant phenolic to meet high heat requirements. As with our appliance handles, these side handles are a fast, economical way to satisfy your product requirements.

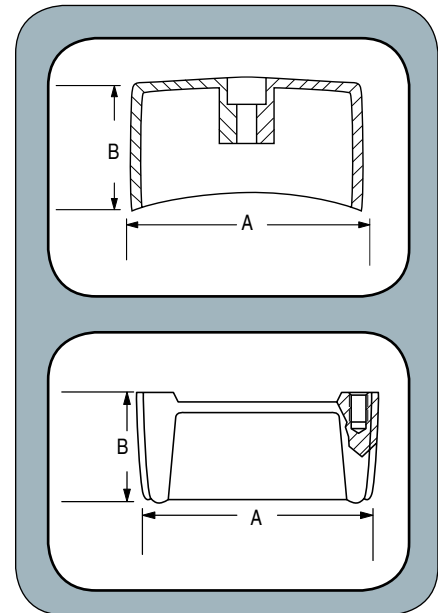
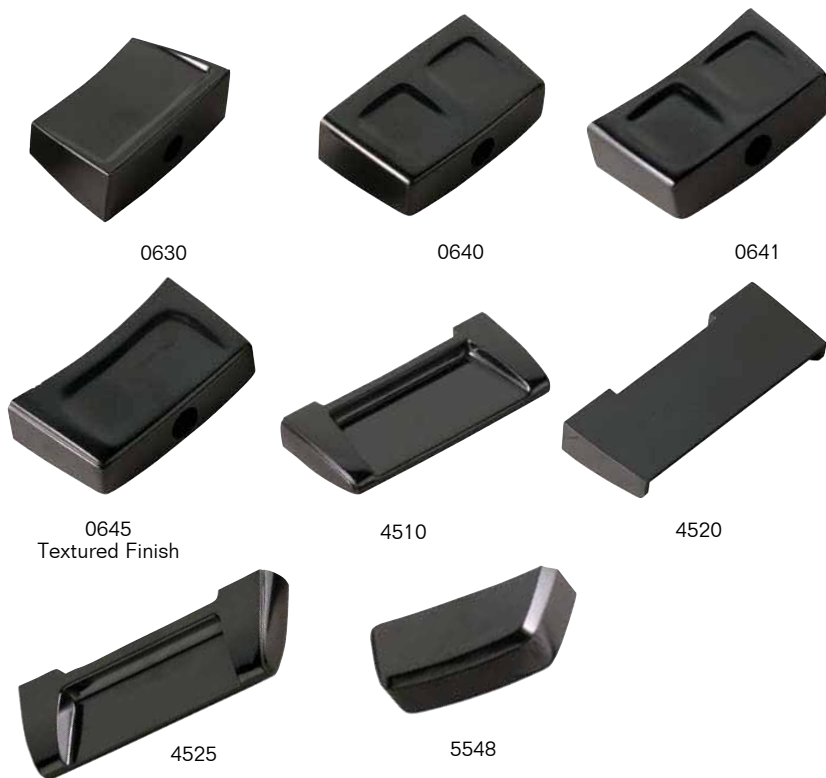

### 630

- 2-3/8" Long x 1-3/8" High
- Mounting Radius 4-5/8"
- Thru Hole for #10 Machine Screw

### 640

- 2-3/8" Long x 1-3/8" Wide
- Mounting 3/16" dia. Thru Hole with 3/8" x 1/4" Counterbore
- STRAIGHT MOUNTING EDGE CAN BE ALTERED TO PROVIDE 3-5/16", 3-3/4", 4-1/16", 4-5/32", 4-1/2", 4-3/4" AND 5-1/2" RADII WITHOUT TOOLING COST

### 641

- 2-3/8" Long x 1-3/8" Wide
- Mounting 3/16" dia. Thru Hole with 3/8" x 1/4" Counterbore
- Mounting Radius 4-5/8"

### 645

- 2-3/8" Long x 1-3/8" Wide
- Mounting Radius 4-5/8"
- Thru Hole for #10 Machine Screw

### 4510

- 2-3/4" Long x 1-1/4" Wide
- Two 8-32 Threaded Plastic Holes or Two .144" dia. Plain Holes on 2-1/4" Centers
- STRAIGHT MOUNTING EDGE ONLY
- MOUNTS FROM FRONT

### 4520

- 3-1/8" Long x 1-1/4" Wide
- Two .156" dia. Thru Mounting Holes on 2-3/8" Centers
- MOUNTS FROM BACK

### 4525

- 4" Long x 1-1/4" Wide
- Two 10-24 or 10-32 Threaded Plastic Holes or Two .162" dia. Plain Holes on 3" Centers
- STRAIGHT MOUNTING EDGE ONLY
- MOUNTS FROM FRONT

### 5548

- 2" Long x 13/16" Wide
- Mounting: One 8-32 Threaded Plastic Hole or .178" dia. Plain Thru Hole
- Standard 10" Mounting Radius can be altered

Material Type	Part No.	A	B	C	D	Tapped Thread					Plain Molded Hole							
						8-32	10-24	10-32	1/4-20	1/4-28	9/64	5/32	13/64	1/4	9/32			
TS	0630	2 3/8	1 3/8	13/16	-	▲	▲	▲	▲	▲	▲	▲	▲	▲	▲	▲	▲	▲
TS	0640	2 1/4	1 3/8	13/16	-	▲	▲	▲	▲	▲	▲	▲	▲	▲	▲	▲	▲	▲
TS	0641	2 3/8	1 3/8	13/16	-	▲	▲	▲	▲	▲	▲	▲	▲	▲	▲	▲	▲	▲
TS	0645	2 3/8	1 7/32	47/64	-	▲	▲	▲	▲	▲	▲	▲	▲	▲	▲	▲	▲	▲
TS	4510	2 3/4	1 1/4	7/16	2 1/4	▲	▲	▲	▲	▲	▲	▲	▲	▲	▲	▲	▲	▲
TS	4520	3 1/8	1 1/4	1/2	2 3/8	▲	▲	▲	▲	▲	▲	▲	▲	▲	▲	▲	▲	▲
TS	4525	3 31/32	1 1/4	9/16	3	▲	▲	▲	▲	▲	▲	▲	▲	▲	▲	▲	▲	▲
TS	5548	2	55/64	19/32	-	▲	▲	▲	▲	▲	▲	▲	▲	▲	▲	▲	▲	▲

\* For parts with male studs. LENGTH projecting below knob must be specified.

- Currently Manufacture/Tooled
- ▲ Could Manufacture/Requires Tooling
- TS Thermoset
- TP Thermoplastic

350 Kehoe Blvd. • Carol Stream, IL 60188 • 800-554-9208 • fax 630-510-9944  
 www.daviesmolding.com • email info@daviesmolding.com



# Feet and Levelers

Our standard line of appliance feet are used in hundreds of ways by thousands of users. Most can be made in heat resistant phenolic to meet high heat requirements. The two exceptions are those with adjustable legs, which are thermoplastic and provide a unique leveling capability by adjusting up to 1-1/4".

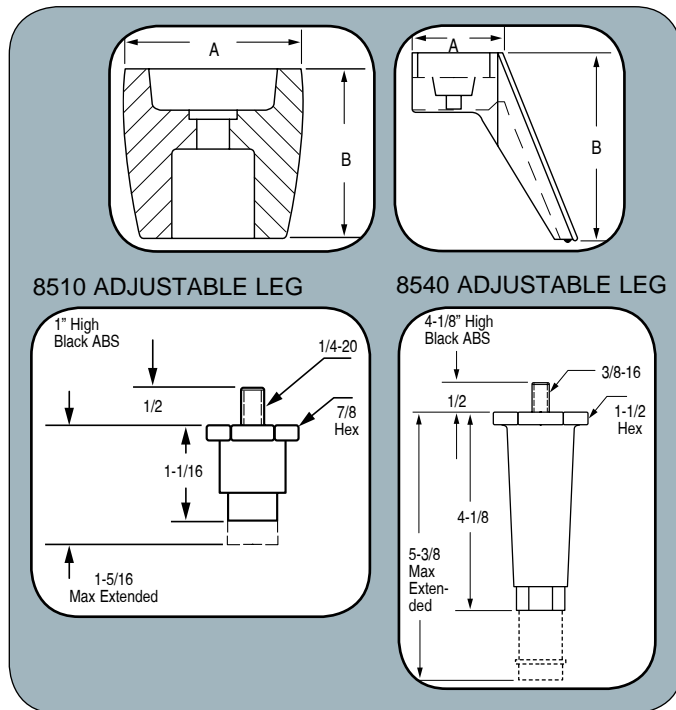

Material Type	Part No.	A	B	Tapped Thread					Plain Molded Hole							
				8-32	10-24	10-32	1/4-20	1/4-28	0.150	0.156	0.168	0.187	0.190	0.196	0.218	
TS	4000	7/8	5/8	▲	■	■	▲	▲	▲	■	▲	■	▲	▲	▲	▲
TS	4005	3/4	5/8	▲	▲	▲	▲	▲	▲	▲	■	▲	▲	▲	▲	▲
TS	4010	3/4	7/8	▲	▲	▲	▲	▲	▲	▲	▲	▲	▲	▲	▲	▲
TS	4020	7/8	7/8	▲	■	▲	■	▲	■	■	▲	■	▲	▲	▲	▲
TS	4030	1	1 1/2	▲	▲	▲	▲	▲	▲	▲	▲	▲	■	■	▲	▲
TS	4040	1	2	▲	■	▲	▲	▲	▲	▲	▲	▲	▲	▲	■	■
TS	4050	7/8	2	▲	▲	▲	▲	▲	▲	▲	▲	■	▲	▲	▲	▲
TS	4060	7/8	1 1/2	▲	▲	▲	▲	▲	▲	▲	▲	■	▲	▲	▲	▲
TS	4070	7/8	2	▲	▲	▲	▲	▲	▲	▲	▲	■	▲	▲	▲	▲
TS	4080	7/8	1 3/4	▲	▲	▲	▲	▲	▲	▲	▲	■	▲	▲	▲	▲

TP | 8510†  
 TP | 8540†

■ Currently Manufacture/Tooled  
 ▲ Could Manufacture/Requires Tooling  
 TS Thermoset  
 TP Thermoplastic  
 † See Line Drawing above

# Instrument Cases & Covers

## General Purpose Phenolic

- Mar and scratch resistant
- Resistant to most chemicals
- Heat resistant to 475°F
- Impact and electrical grades
- Glossy Black – Provides a high lustre finish
- Various Colors available
- Machining by Davies available

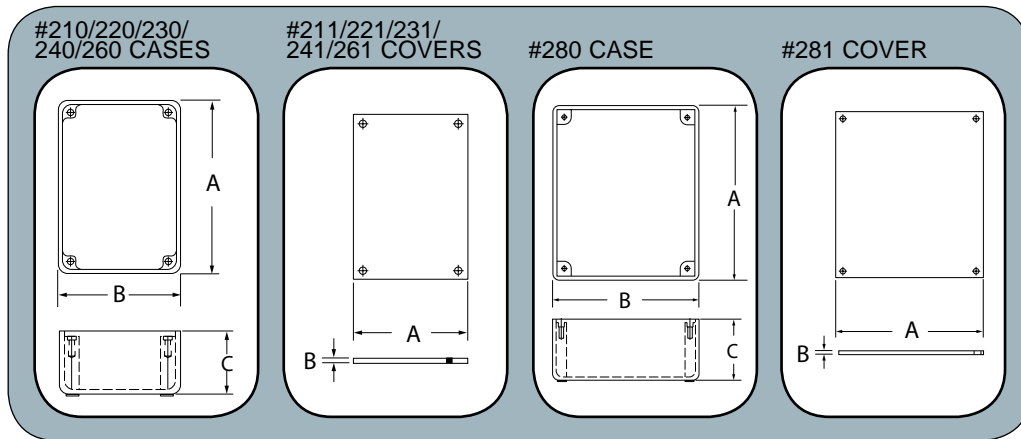

## Cases

Material Type Hardware	Part No.	A	B	C	Mounting Holes x Depth	
TS	0210A	3 1/2"	2 1/2"	1 1/4"	4-40 X 5/16"-TH (4)	4-40 X 1/2" Screw
TS	0220	4"	2 7/8"	1 9/16"	4-36 X 5/16"-TH (4)	4-36 X 1/2" Screw
TS	0220A	4"	2 7/8"	1 9/16"	4-40 X 5/16"-TH (4)	4-40 X 1/2" Screw
TS	0220B	4"	2 7/8"	1 9/16"	.099 X 7/16"-PH (4)	1/2" #4 Self Tap
TS	0230	5"	4 1/4"	1 3/4"	.099 X 7/16"-PH (4)	1/2" #4 Self Tap
TS	0230A	5"	4 1/4"	1 3/4"	6-32 X 5/16"-TI (4)	6-32" X 3/8" Screw
TS	0240	6 1/4"	3 3/4"	2"	.113 X 1/2"-PH (4)	1/2" #6 Self Tap
TS	0240B	6 1/4"	3 3/4"	2"	6-32 X 5/16"-TI (4)	6-32" X 3/8" Scre
TS	0260	6 13/16"	5 9/32"	2 5/16"	.089 X 1/2"-PHCH	1/2" #4 Self Tap
TS	0260K	6 13/16"	5 9/32"	2 5/16"	5/16" X 1/16"-TI (4)	6-32" X 3/8" Screw
TS	0280	8 7/16"	7 7/16"	3 1/64"	6-32 X 1/4"-TI (6)	6-32" X 3/8" Screw

## Covers

Material Type No.	Part No.	A	B	Case
TS	0211	2 19/64"	1/16"	210
TS	0221	2 17/64"	1/16"	220/220A/220B
TS	0231	4"	1/16"	230/230A
TS	0241	3 47/64"	1/4"	240/240B
TS	0245	3 47/64"		COVER W/READOUT OPENING
TS	0261	5 17/64"	1/4"	260/260K

# Instrument Cases & Covers



0225



0250

Hi-impact A.B.S. thermoplastic, perfect for nearly every hard use industrial and electronic application. Easily machined – will not chip or crack during fabrication.

**TYPICAL WALL THICKNESS: ALL PARTS .080"**

- Satin Finish
- Spectrum Colors on Request
- Available in KJB CYCOLAC  
An improved thermoplastic with a flammability rating of 94 V-O at .080" thickness and continue use temperature of 70°
- Four Plain Holes  
For self tapping screws
- Printed Circuit Boards (225)  
Two guides on long side  
One guide on short side  
Guides accept .062" thick cards
- Printed Circuit Boards (250 only)  
Three guides on long side  
Two guides on short side  
Guides accept .062" thick cards
- Partitions  
Guides can be used for partitioning of electric components
- Stand Offs (250 only)  
Four posts .120" I.D. x 11/32" Deep  
For #6 Self Tapping Screw-Type AB on bottom for easy P.C. board mounting
- Wall Mount (250) only  
Two knock-outs on case  
Two knock-outs on cover
- Interlocking Cover

**#225 CASE**

Standard Mountings:  
.099 x 5/16" Plain Plastic Holes

Inside Dimensions:  
3-25/32" L x 2-21/32" W x 1-15/32" D

**#225 CASE**

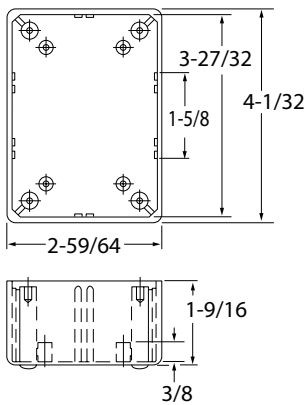

**#226 MATING COVER**

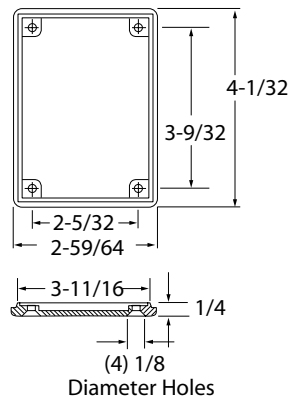

**#250 CASE**

Standard Mountings:  
(4) .120 x 11/32" Plain Holes

Inside Dimensions:  
6-3/32" L x 3-19/32" W x 1-59/64" D

**#250 CASE**

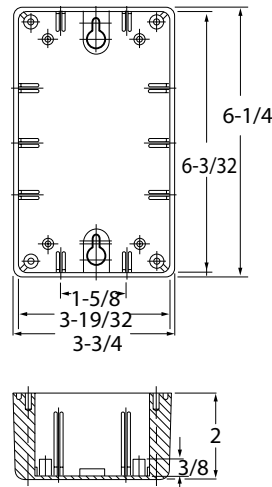

**#251 MATING COVER**

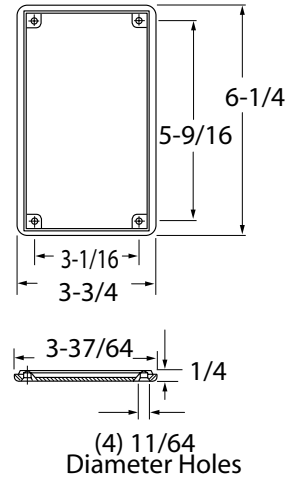

# Handle Series MS

Machine, instrument, and equipment handles for universal use and for any hole spacings. Extra rugged design with excellent engineering. Handle ledge and elbow section plug press-connected. Elbow sections made of diecast aluminum, connecting grip ledge of aluminum profile tubing. Handle elbow section black powder-coated, semi-matte, with fine structure; aluminum connecting grip ledge, satin finish anodized in natural color.

Includes black-galvanized cap head screws with hexagon socket M12 x 70, galvanized washers and nuts. Grip ledge and elbow sections are preassembled.

Specified handle lengths are available upon request.

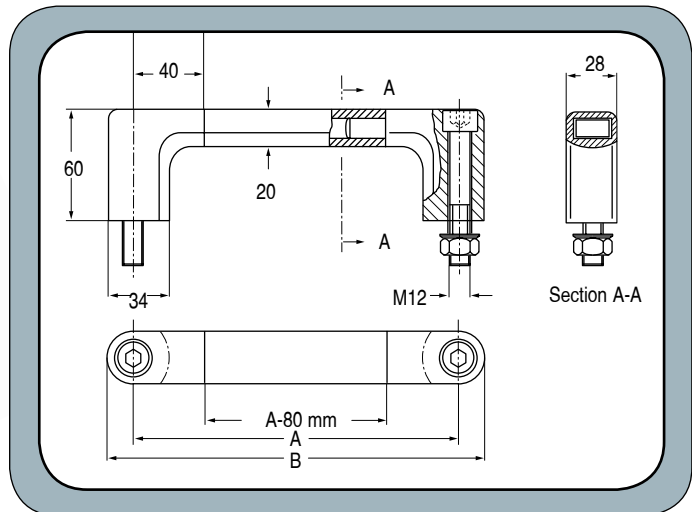

A	Part No.	B
180	MS-01.180.62	208
200	MS-01.200.62	228
250	MS-01.250.62	278
300	MS-01.300.62	328
350	MS-01.350.62	378
400	MS-01.400.62	428
500	MS-01.500.62	528
600	MS-01.600.62	628

All dimensions in metric

# Plastic Handle Series EC New!

Economical handles made from high strength polyamide PA 6, glass ball reinforced, black or orange color. Hole for cylinder head socket screws M8 or countersunk head socket screws M6. Stress resistance: min. 1000 N

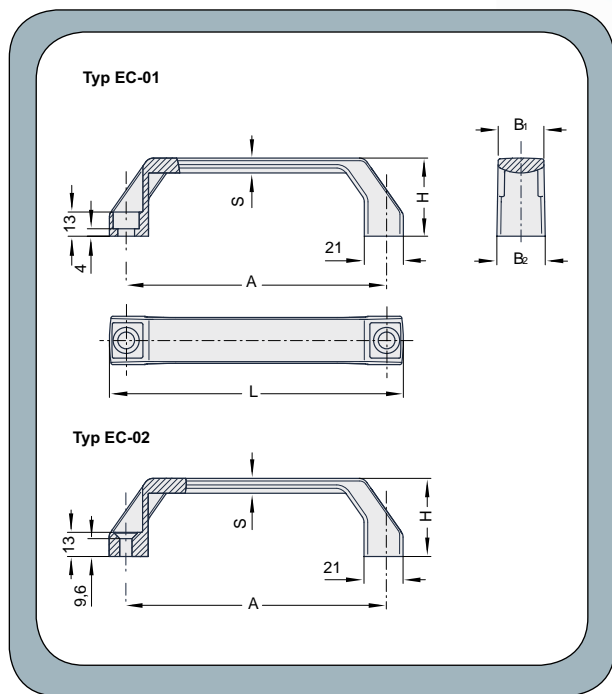

A	Color	EC-01 for cylinder head screws	EC-02 for countersunk screws	L	B1	B2	H	S
120	Black	EC-01.120.84	EC-02.120.84	138	24.5	26	42	8
	Orange	EC-01.120.09	EC-02.120.09					
140	Black	EC-01.140.84	EC-02.140.84	158	24.5	26	42	8
	Orange	EC-01.140.09	EC-02.140.09					
160	Black	EC-01.160.84	EC-02.160.84	178	26.5	28	45	9
	Orange	EC-01.160.09	EC-02.160.09					

All dimensions in metric





# Plastic Handle Series KW

Handles designed for one-sided fastening. Extremely durable with a stress resistance of min. 800 N.

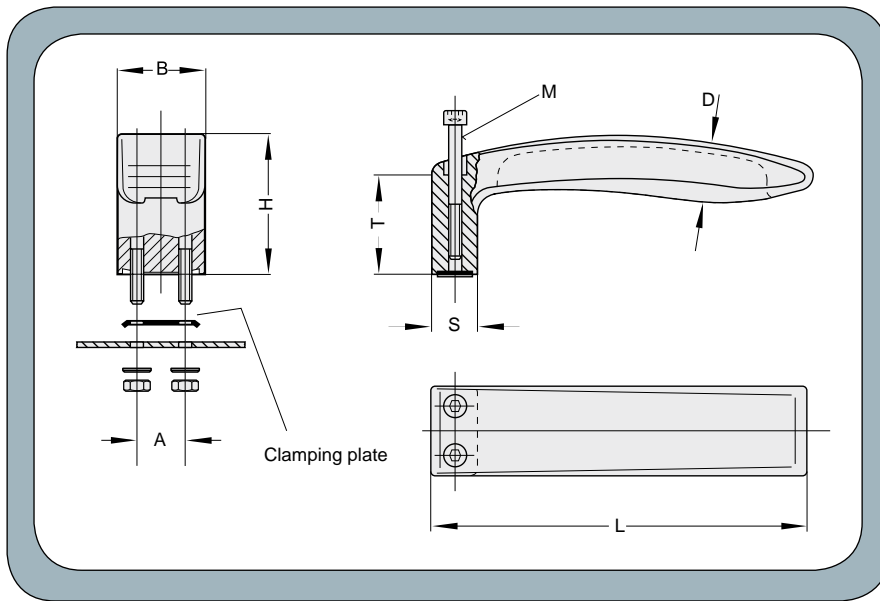

A	Part No.	L	M	T	B	H	D	S
17	KW-30.017.84	128	M5x45	33	30	48	20	18
20	KW-36.020.84	154	M6x55	40	36	58	24	22

All dimensions in metric.

# Plastic Handle Series KM New!

Two ergonomic versions of the secure fit KM plastic handle made from thermoplastic polyamide PA 6, glass ball reinforced suitable for different wall thickness. Simple and secure screw mounting with threaded brass bushing for housing panel thickness of 1-5 mm. KM-48 front section is first set into the recess in the housing panel. The rear section is now pushed onto the front section which projects into the housing interior. The handle is then fixed in position with the aid of three screws. Includes galvanized oval-head screws. KM-61 is set into the recess of the housing wall and fixed front sided with 2 countersunk screws, not included.



KM-48

Mounting cutout

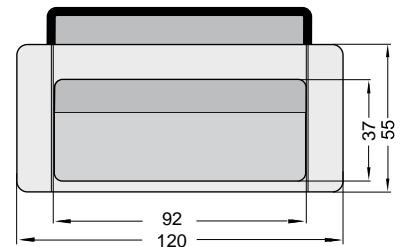
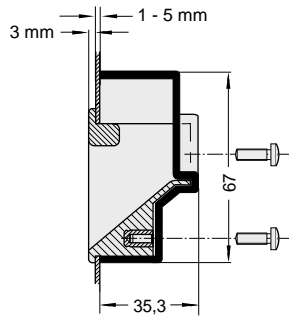
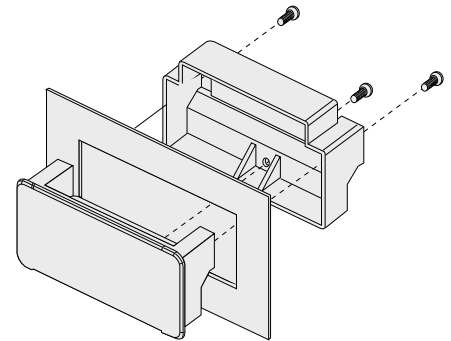
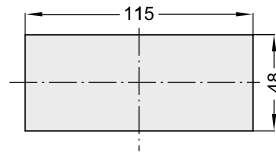

Part No.	L	A	B	Color
KM-48.115.7030	100	82	67	stone grey
KM-48.115.7035	100	82	67	light grey
KM-48.115.9002	100	82	67	grey white
KM-48.115.9005	100	82	67	black

All dimensions in metric



KM-61

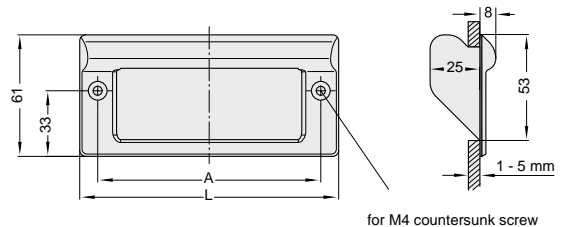

for M4 countersunk screw

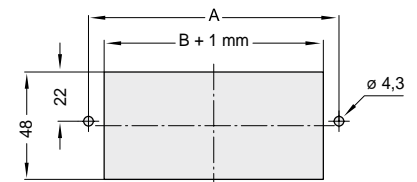
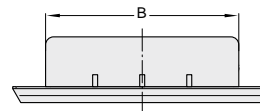

Mounting cutout

Part No.	L	A	B	Color
KM-61.082.7030	100	82	67	stone grey
KM-61.082.7035	100	82	67	light grey
KM-61.082.9002	100	82	67	grey white
KM-61.082.9005	100	82	67	black
KM-61.112.7030	130	112	97	stone grey
KM-61.112.7035	130	112	97	light grey
KM-61.112.9002	130	112	97	grey white
KM-61.112.9005	130	112	97	black

All dimensions in metric



# Plastic Sliding Tray Handle KS

This variable shove-inset handle is developed for the vertical installation into machine- and housing doors. Simple and stable mounting with threaded brass bushing. Robust formation of the tray interior, non-slip grip in both movement directions. Suitable for a panel thickness between 1-5 mm. The front section is first set into the recess in the housing panel. The rear section is now pushed onto the front section which projects into the housing interior. The handle is then fixed in position with the aid of four galvanized oval-head screws, included.

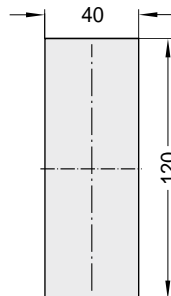
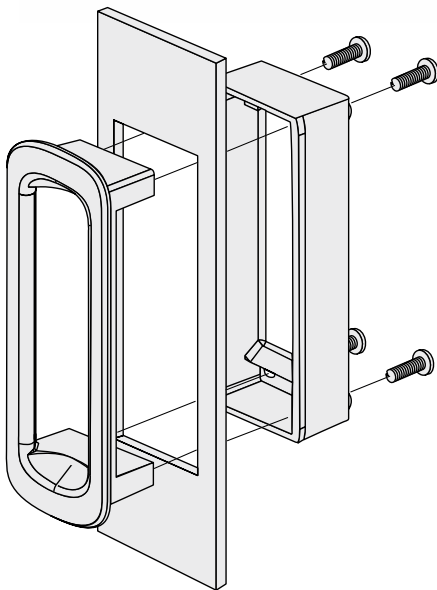
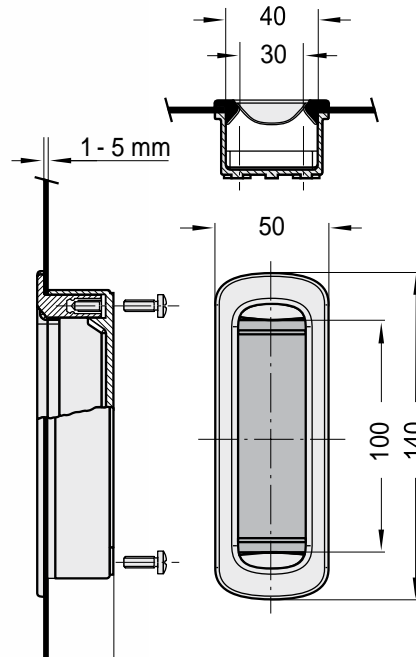

Mounting cutout

Color	Part no.
stone grey	KS-40.120.7030
light grey	KS-40.120.7035
grey white	KS-40.120.9002
black	KS-40.120.9005

# Plastic Hinged Handle KK New!

Plastic hinged handle for screwing onto the housing wall, springs back automatically. Holder and handle are made of heavy-duty polyamide, glassball reinforced, black, semigloss, with finegrain structure. Arbors and restoring springs made of stainless steel. Stability under load: 500 N per piece. Includes black galvanized cross recessed countersunk flat head screws M6 x 30 and nuts with washers. Other color versions or combinations available on request.

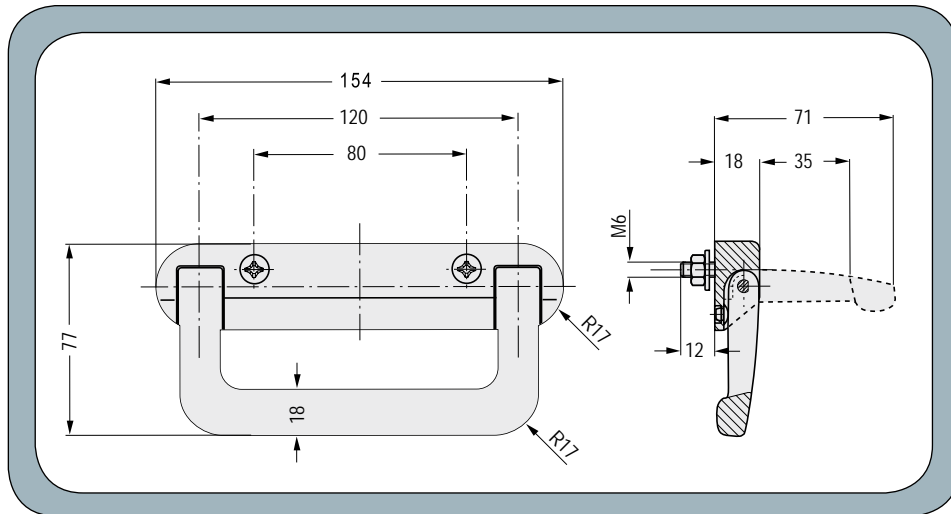

	Part No.
Hinged Handle Black Plastic KK	KK-18.120.84

All dimensions in metric



# Plastic Handle Series MA

For instruments, cases, and similar application made with black soft plastic. MA-37 and MA-25 handles have a steel spring inside and black plastic cover caps for front mounting with countersunk screws (not included.) MA-23 and MA-20 handles made with nickel-plated steel cover caps. MA-23 handles have a steel spring inside.

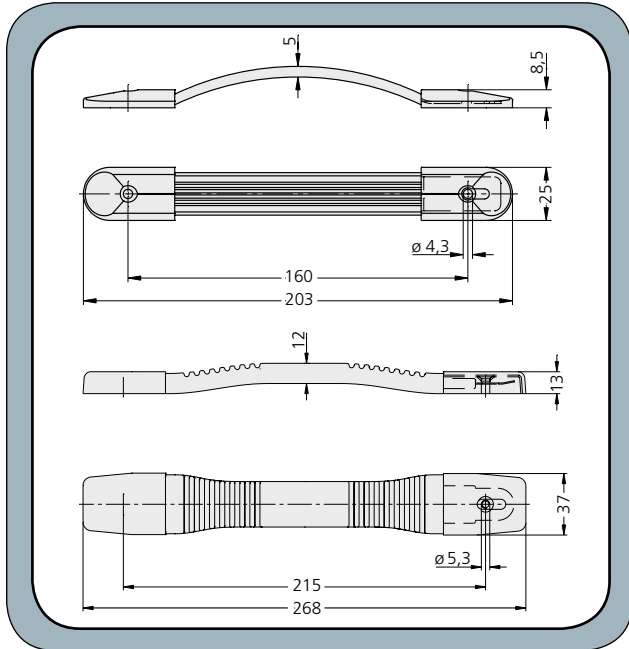

MA-37.215.84  
For M5 countersunk screws



MA-25.160.84  
For M4 countersunk screws

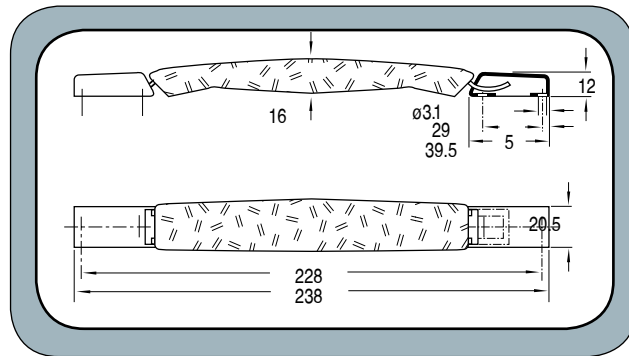

MA-20.228.84



MA-23.187.84

MA-23.205.84

	Part No.
Fastening from below with sheet metal screw	MA-20.228.84

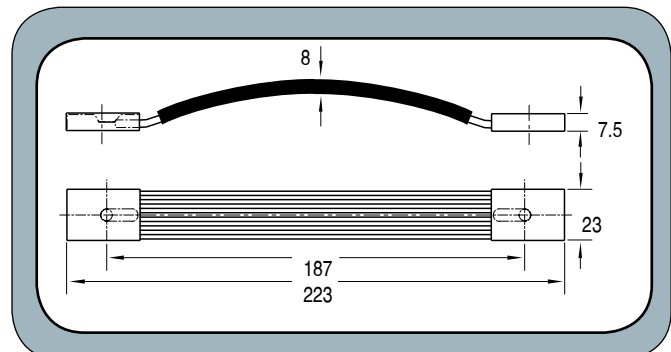
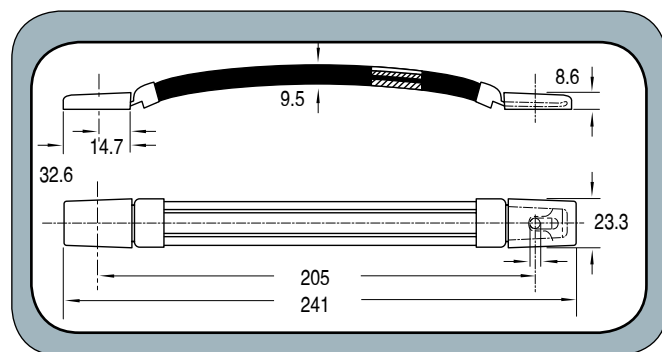

	Part No.
For M4 countersunk screw	MA-23.205.84

	Part No.
For M4 countersunk screw	MA-23.187.84

# Plastic SK Series

**New!**

Our most popular collapsible tray handle now available in durable thermoplastic polyamide PA 6, black. These collapsible tray handles feature a contemporary design and are used wherever both durability and attractive styling are required. Mountable in front of or behind the housing wall with the same housing cutout. Natural finger profiling at the rear of the hinged handle. Can also be used for lifting a device in the retracted state. Type SK-P79.S: With snap locks both in rest and work position. Type SK-P79.R: With pull back spring from the working to the rest position.

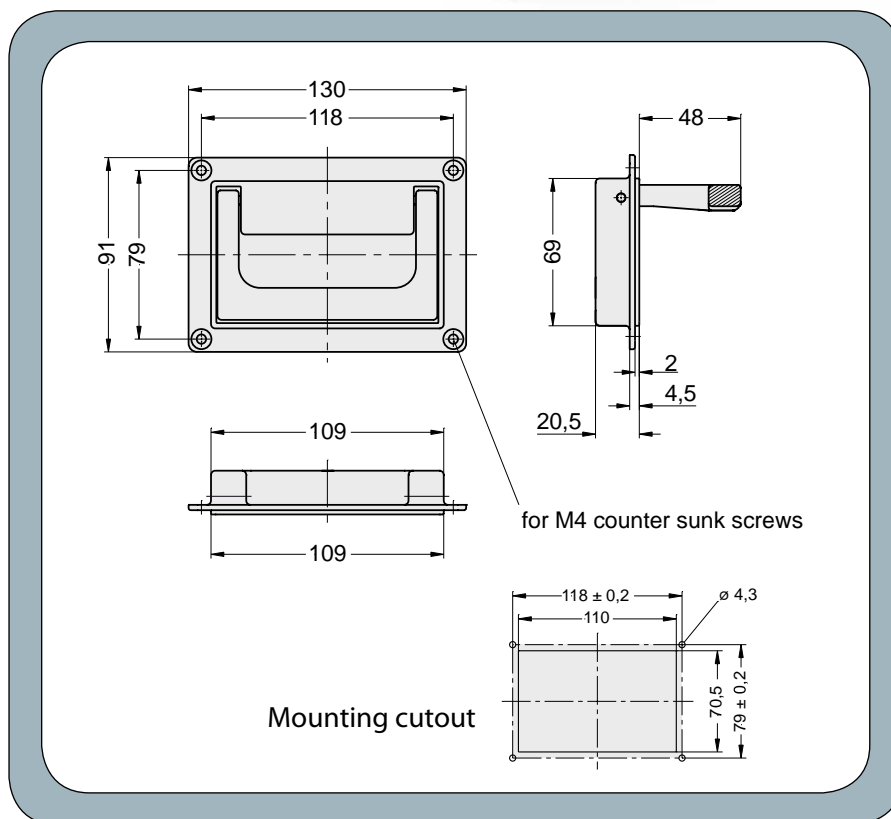

Color	With Snap Locks	With Pull Back Spring
black	SK-79.S118.84	SK-79.R118.84

Thermoplastic SK

# Aluminum R Series

Particularly versatile and attractive series for 19" drawers and instruments. Made from Profile aluminum AiMgSi 0.5. Vibration ground and anodized to a matte finish in natural or black color. Types R1 & R2 differ in width and in size of thread and can therefore be adapted to case specifications. Type R3 screws mounting from the front. Includes stainless steel cheese head screws with hexagon socket M 5 x 45 and galvanized, self-locking ratchet nuts. Custom colors available.

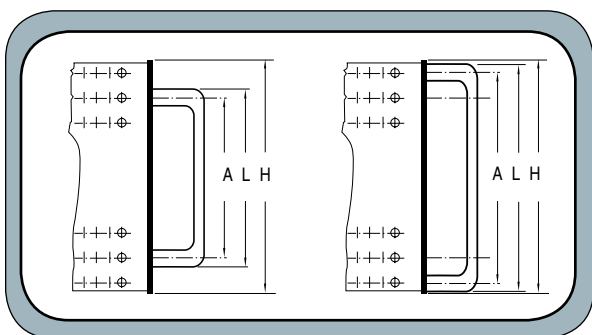
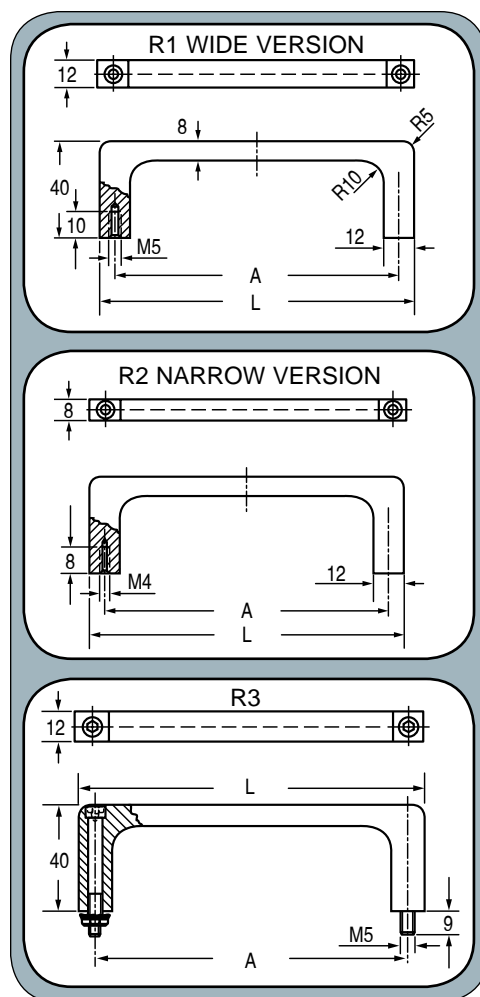

HE = unit of height  
 1 HE = 44.45 mm - 1-5/8"  
 Height of front panels = HE x 44.45 mm - 0.8 mm  
 L = H - 0.5 MM

Suitable Mounting Version	L	A	Height of Front Panel H	Handle Color	Type R1 Part No.	Type R2 Part No.	Type R3 Part No.
1	67	55	88.1 (2HE)	Natural Black	R1-12.055.01 R1-12.055.04	R2-08.055.01 R2-08.055.04	R3-12.055.01 R3-12.055.04
	100	88	132.5 (3HE)	Natural Black	R1-12.088.01 R1-12.088.04	R2-08.088.01 R2-08.088.04	R3-12.088.01 R3-12.088.04
	132	120	177.0 (4HE)	Natural Black	R1-12.120.01 R1-12.120.04	R2-08.120.01 R2-08.120.04	R3-12.120.01 R3-12.120.04
	192	180	221.5 (5HE)	Natural Black	R1-12.180.01 R1-12.180.04	R2-08.180.01 R2-08.180.04	R3-12.180.01 R3-12.180.04
	247	235	266.0 (6HE)	Natural Black	R1-12.235.01 R1-12.235.04	R2-08.235.01 R2-08.235.04	R3-12.235.01 R3-12.235.04
2	43.5	32.0	44.0 (1HE)	Natural Black	R1-12.032.01 R1-12.032.04	R2-08.032.01 R2-08.032.04	R3-12.032.01 R3-12.032.04
	87.5	75.5	88.1 (2HE)	Natural Black	R1-12.075.01 R1-12.075.04	R2-08.075.01 R2-08.075.04	R3-12.075.01 R3-12.075.04
	132.0	120.0	132.5 (3HE)	Natural Black	R1-12.120.01 R1-12.120.04	R2-08.120.01 R2-08.120.04	R3-12.120.01 R3-12.120.04
	265.5	253.5	266.0 (6HE)	Natural Black	R1-12.253.01 R1-12.253.04	R2-08.253.01 R2-08.253.04	R3-12.253.01 R3-12.253.04

All dimensions in metric

# Aluminum KG Series

Control Panel handles made from round bar aluminum, AlMgSi 0.5. Ground, glass-bead-blasted, black satin finish. All handle lengths available on request.

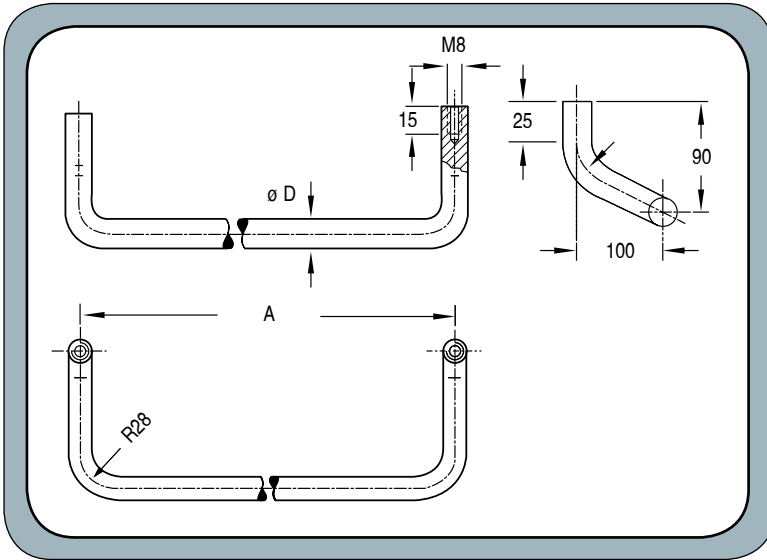

A	Part No.	$\phi D$
200	KG-16.200.14	16
250	KG-16.250.14	
300	KG-16.300.14	
350	KG-16.350.14	
400	KG-16.400.14	
450	KG-16.450.14	
500	KG-18.500.14	18
550	KG-18.550.14	
600	KG-18.600.14	
650	KG-18.650.14	

All dimensions in metric



Installation Hardware	Handle $\phi D$	Part No.
Al-cover plates, black anodized, semi-matte finish, pack of 2 pcs.	16	KG-16.000.04
Al-cover plates, black anodized, semi-matte finish, pack of 2 pcs.	18	KG-18.000.04



# Aluminum Handle SK



These collapsible tray handles feature a contemporary design and are used wherever both durability and attractive styling are required. Mountable in front of or behind the housing wall with the same housing cutout. Natural finger profiling at the rear of the hinged handle. Can also be used for lifting a device in the retracted state.

Type SK-50.S and SK-79.S have a snap-lock, and hold both in rest and work positions. Type SK-50.R and SK-79.R have a pull-back spring and retract from the working to the rest position.

Made of pressure-molded aluminum with a black or light grey powder-coated half-matte finish.

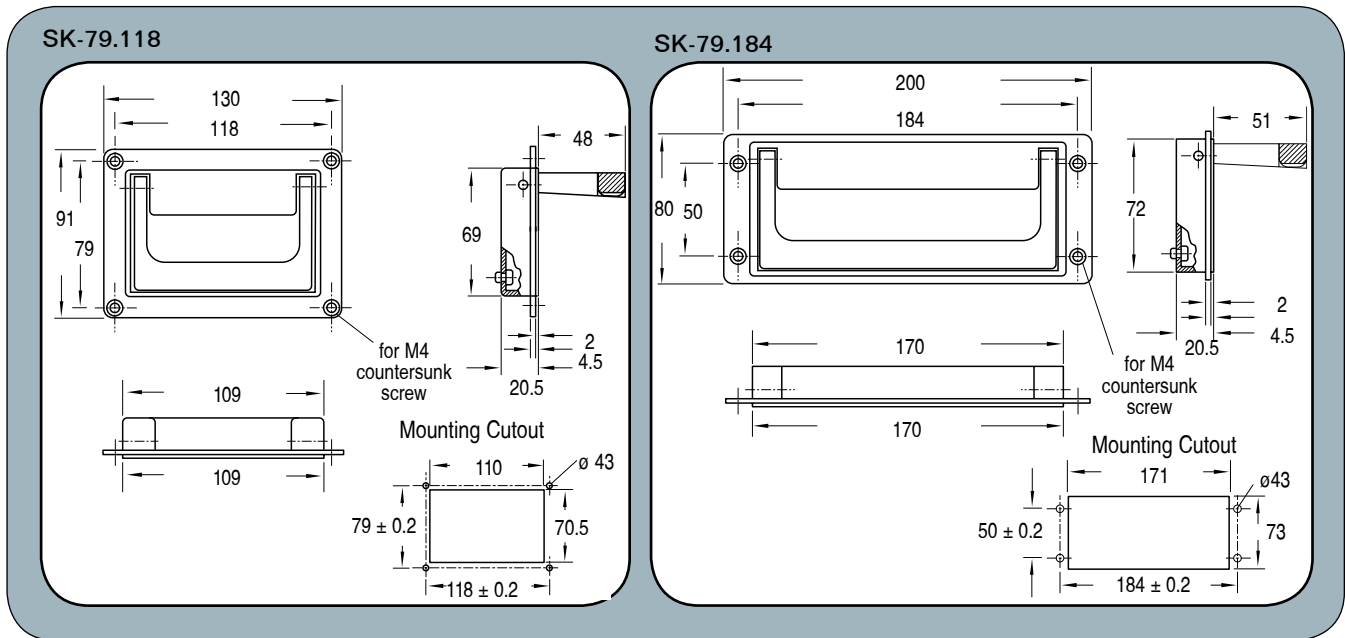

Supply Versions	SK-79.S w/ Snaplock Part No.	SK-79.R w/ Pull-Back Spring Part No.	SK-50.S w/ Snaplock Part No.	SK-50.R w/ Pull-Back Spring Part No.
Black	SK-79.S118.9005	SK-79.R118.9005	SK-50.S184.9005	SK-50.R184.9005
Light Grey	SK-79.S118.7035	SK-79.R118.7035	SK-50.S184.7035	SK-50.R184.7035
Without Enamel and Unassembled	SK-79.S118.00	SK-79.R118.00	SK-50.S184.00	SK-50.R184.00

All dimensions in metric

# Aluminum S Series

Standard versions for 19" drawers and instruments. Made of cut profiled aluminum with an anodized matte finish in natural color or black. All dimensions are shown in mm. All dimensions and thread sizes are available in English units.

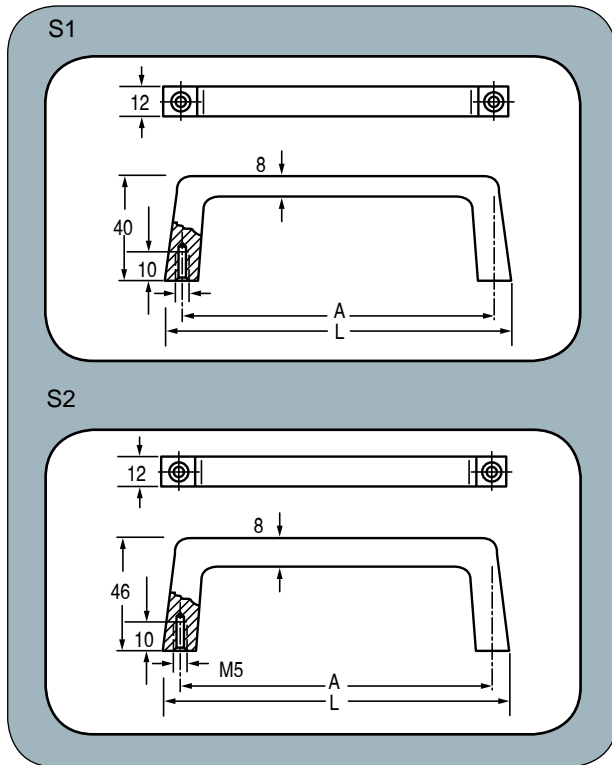

Type	L (mm)	A (mm)	Natural Part No.	Black Part No.
S1	40	25	S1-12.025.01	S1-12.025.04
	69	55	S1-12.055.01	S1-12.055.04
	102	88	S1-12.088.01	S1-12.088.04
	134	120	S1-12.120.01	S1-12.120.04
	146.5	134.4	S1-12.133.01	S1-12.133.04
	191	177.8	S1-12.177.01	S1-12.177.04
	194	180	S1-12.180.01	S1-12.180.04
	249	235	S1-12.235.01	S1-12.235.04
	265.5	251.5	S1-12.251.01	S1-12.251.04
S2	102	88	S2-12.088.01	S2-12.088.04
	132	120	S2-12.120.01	S2-12.120.04
	265.5	251.5	S2-12.251.01	S2-12.251.04

All dimensions in metric

# Aluminum RA Series

Round bar aluminum. Anodized in natural or black with a matte finish. Also available in a satin finish version which is surface glass-bead-blasted in a natural satin or black anodized finish. All dimensions are shown in mm. All dimensions and thread sizes are available in English units.

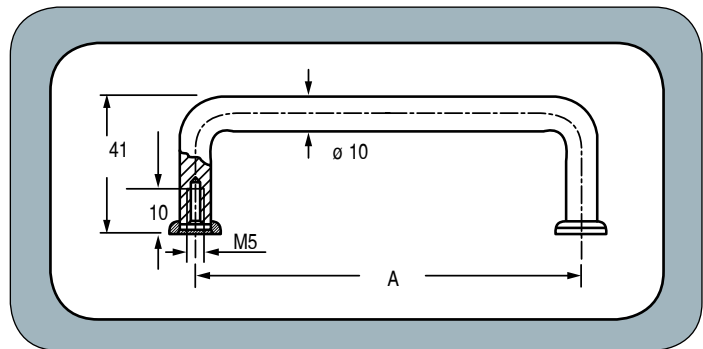

A	Standard		Satin-finish	
	Natural Part No.	Black Part No.	Natural Part No.	Black Part No.
55	RA-10.055.01	RA-10.055.04	RA-10.055.11	RA-10.055.14
88	RA-10.088.01	RA-10.088.04	RA-10.088.11	RA-10.088.14
100	RA-10.100.01	RA-10.100.04	RA-10.100.11	RA-10.100.14
120	RA-10.120.01	RA-10.120.04	RA-10.120.11	RA-10.120.14
180	RA-10.180.01	RA-10.180.04	RA-10.180.11	RA-10.180.14
200	RA-10.200.01	RA-10.200.04	RA-10.200.11	RA-10.200.14
235	RA-10.235.01	RA-10.235.04	RA-10.235.11	RA-10.235.14
250	RA-10.250.01	RA-10.250.04	RA-10.250.11	RA-10.250.14

## Standard Version Cover Plates

Cover Plates	Part No.
Al cover plates, natural (pack of 20 pieces)	RA-10.000.01
Al cover plates, black (pack of 20 pieces)	RA-10.000.04

All dimensions in metric

# Aluminum OA Series

Made of oval aluminum. Anodized in natural or black with a matte finish. Also available in a satin finish version which is surface glass-bead-blasted in a natural satin or black anodized finish. All dimensions are shown in mm. All dimensions and thread sizes are available in English units.

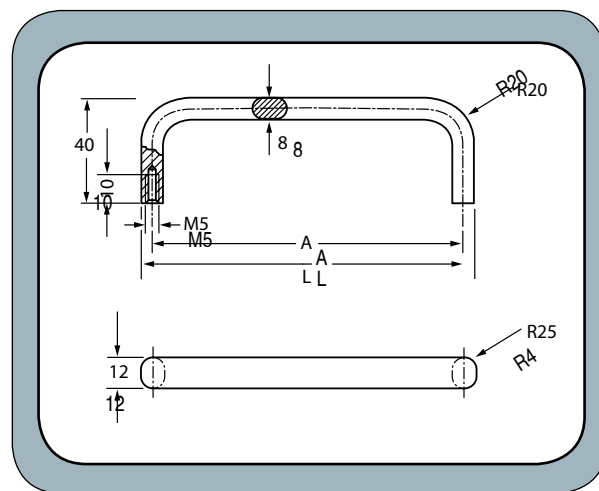

A	L	Natural Part No.	Black Part No.
55	63	OA-12.055.01	OA-12.055.04
88	96	OA-12.088.01	OA-12.088.04
100	108	OA-12.100.01	OA-12.100.04
120	128	OA-12.120.01	OA-12.120.04
180	188	OA-12.180.01	OA-12.180.04
200	208	OA-12.200.01	OA-12.200.04
235	243	OA-12.235.01	OA-12.235.04
250	258	OA-12.250.01	OA-12.250.04

All dimensions in metric

All dimensions in metric

# Aluminum MO Series

Oval profiled aluminum alloy. Standard models are surface ground and anodized with a matte finish, or powder coated. The satin finished version is glass blasted and anodized in natural or black with a satin finish surface.



Handle Type	A	Surface Index	Standard	Satin-finish
MO-20	100	Natural	MO-20.100.01	MO-20.100.11
		Black Anodized	MO-20.100.04	MO-20.100.14
		Powder Coated, Black Semi-Matte	MO-20.100.54	-
	112	Natural	MO-20.112.01	MO-20.112.11
		Black Anodized	MO-20.112.04	MO-20.112.14
Powder Coated, Black Semi-Matte		MO-20.112.54	-	
120	Natural	MO-20.120.01	MO-20.120.11	
	Black Anodized	MO-20.120.04	MO-20.120.14	
	Powder Coated, Black Semi-Matte	MO-20.120.54	-	
128	Natural	MO-20.128.01	MO-20.128.11	
	Black Anodized	MO-20.128.04	MO-20.128.14	
	Powder Coated, Black Semi-Matte	MO-20.128.54	-	
160	Natural	MO-20.160.01	MO-20.160.11	
	Black Anodized	MO-20.160.04	MO-20.160.14	
	Powder Coated, Black Semi-Matte	MO-20.160.54	-	
MO-26	112	Natural	MO-26.112.01	MO-26.112.11
		Black Anodized	MO-26.112.04	MO-26.112.14
		Powder Coated, Black Semi-Matte	MO-26.112.54	-
	120	Natural	MO-26.120.01	MO-26.120.11
		Black Anodized	MO-26.120.04	MO-26.120.14
		Powder Coated, Black Semi-Matte	MO-26.120.54	-
	128	Natural	MO-26.128.01	MO-26.128.11
		Black Anodized	MO-26.128.04	MO-26.128.14
Powder Coated, Black Semi-Matte		MO-26.128.54	-	
160	Natural	MO-26.160.01	MO-26.160.11	
	Black Anodized	MO-26.160.04	MO-26.160.14	
	Powder Coated, Black Semi-Matte	MO-26.160.54	-	
180	Natural	MO-26.180.01	MO-26.180.11	
	Black Anodized	MO-26.180.04	MO-26.180.14	
	Powder Coated, Black Semi-Matte	MO-26.180.54	-	
192	Natural	MO-26.192.01	MO-26.192.11	
	Black Anodized	MO-26.192.04	MO-26.192.14	
	Powder Coated, Black Semi-Matte	MO-26.192.54	-	
350	Natural	MO-26.350.01	MO-26.350.11	
	Black Anodized	MO-26.350.04	MO-26.350.14	
	Powder Coated, Black Semi-Matte	MO-26.350.54	-	

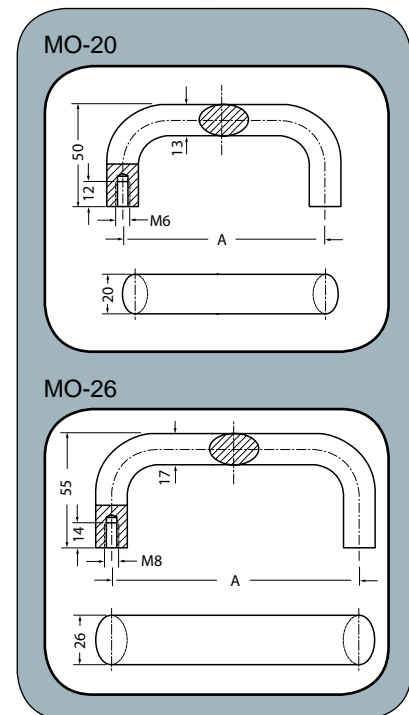

All dimensions in metric

# Aluminum RR Series

Multi purpose handle types in 2 design dimensions, similar to series RS, for engineering and building apparatuses. Particularly suitable for handle mounting in corners or between opposite wall surfaces. The handle shank RR-20 is provided with 4 triangular PVC profiles and the handle shank RR-30 with 2 triangular PVC profiles, inside of the pipe connection. When the round tube is pressed in, the plastic profiles will shear and give a firm, snug fit.

Handle shanks made of engineering grade nylon, glass ball reinforced, black, similar to semi-matte, with fine structure. Connecting tubes made of aluminum.

VERSION A: Connecting tube ground and anodized in natural color.

VERSION B: Connecting tube with grooved plastic cover.

RR-20 is supplied with black galvanized hexagon screw M5 x 20 and galvanized nuts with washers. RR-30 same as above but with screw M8 x 25.

Desired handle lengths are available upon request.

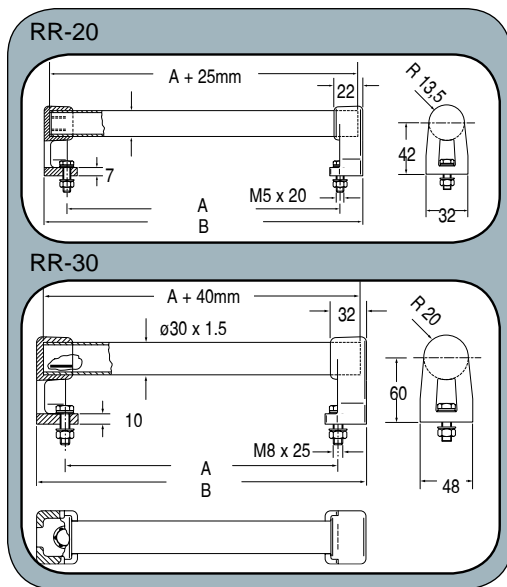

### Single Components

Item	Part No.
Handle shank, 1 piece, with mounting material	RR-20.000.84
	RR-30.000.84
Handle shank, 1 piece, without mounting material	RR-20.0WS.84
Connecting tube, 1 m Version A	RR-20.001.01
	RR-30.001.01

A	Type RR-20			Type RR-30		
	Version A Part No.	Version B Part No.	B	Version A Part No.	Version B Part No.	B
150	RR-20.150.62	RR-20.150.63	184	RR-30.150.62	RR-30.150.63	200
200	RR-20.200.62	RR-20.200.63	234	RR-30.200.62	RR-30.200.63	250
250	RR-20.250.62	RR-20.250.63	284	RR-30.250.62	RR-30.250.63	300
300	RR-20.300.62	RR-20.300.63	334	RR-30.300.62	RR-30.300.63	350
350	RR-20.350.62	RR-20.350.63	384	RR-30.350.62	RR-30.350.63	400
400	RR-20.400.62	RR-20.400.63	434	RR-30.400.62	RR-30.400.63	450
500	RR-20.500.62	RR-20.500.63	534	RR-30.500.62	RR-30.500.63	550
600	RR-20.600.62	RR-20.600.63	634	RR-30.600.62	RR-30.600.63	650

All dimensions in metric

# Aluminum MF Series

Handle series suitable for engineering, instruments, and apparatus building. Flat oval profiled aluminum alloy. Ground and anodized in natural or black with a matte finish. All dimensions are shown in mm. All dimensions and thread sizes are available in English units.

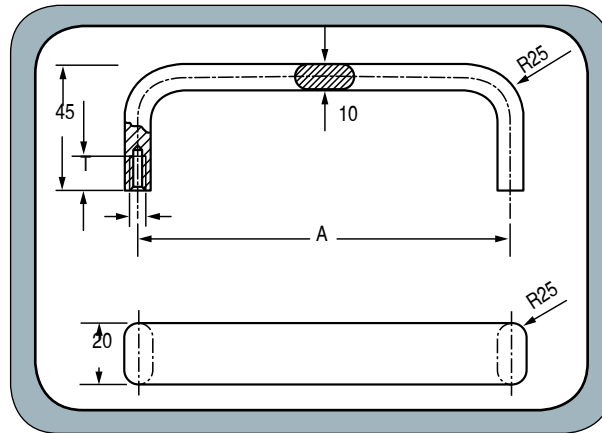

A	Natural Part No.	Black Part No.	M	T
120	MF-20.120.01	MF-20.120.04	5	10
180	MF-20.180.01	MF-20.180.04		
200	MF-20.200.01	MF-20.200.04		
350	MF-20.350.01	MF-20.350.04	6	12

All dimensions in metric

# Steel Cranked Machine Handles AM

Round steel rod, 12 mm diameter. Precision-ground and chromium-plated mirror finish. Additional sizes or surface versions are available upon request.

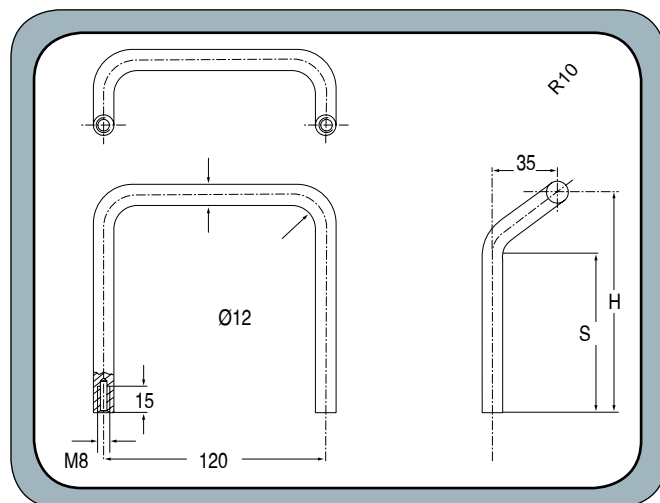

H	Part No.	S
60	AM-27.120.22	27
120	AM-87.120.22	87

# Round Bar Steel ST Series

Quality handles with tapped mounting holes. Round steel bar, precision ground and high gloss chrome plated surface, including chrome plated brass cover washers. All dimensions are shown in mm. All dimensions and thread sizes are available in English units.

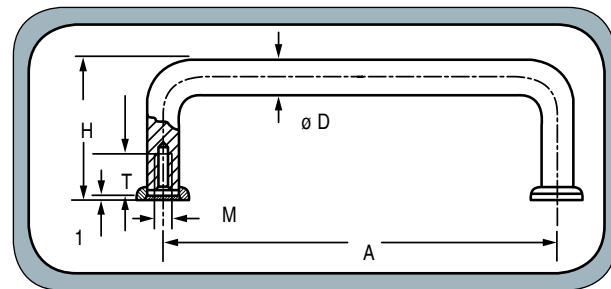

A	Part No.	ØD	H	M	T
32	ST-05.032.22	5	21	3	6
42	ST-05.042.22				
55	ST-05.055.22				
76	ST-05.076.22				
88	ST-05.088.22	8	33	4	8
32	ST-08.032.22				
55	ST-08.055.22				
64	ST-08.064.22				
88	ST-08.088.22				
96	ST-08.096.22				
98	ST-08.098.22				
102	ST-08.102.22				
120	ST-08.120.22	10	41	5	10
128	ST-08.128.22				
136	ST-08.136.22				
55	ST-10.055.22				
88	ST-10.088.22				
100	ST-10.100.22				
102	ST-10.102.22				
115	ST-10.115.22				
120	ST-10.120.22				
136	ST-10.136.22				
180	ST-10.180.22				
200	ST-10.200.22				
235	ST-10.235.22				
250	ST-10.250.22				

All dimensions in metric



# Stainless Steel EF Series

Attractively shaped handles for all applications, with high corrosive and chemical resistance. Made of sectional high grade stainless steel, available in two styles. Version A is surface vibration ground with a semi-matte finish. Version B is surface vibration ground, blasted and electropolished with a semi-matte finish. Both versions include high grade steel hexagonal head screws and washers. Wide design: screws M6 x 12; Narrow design: screws M5 x 10.

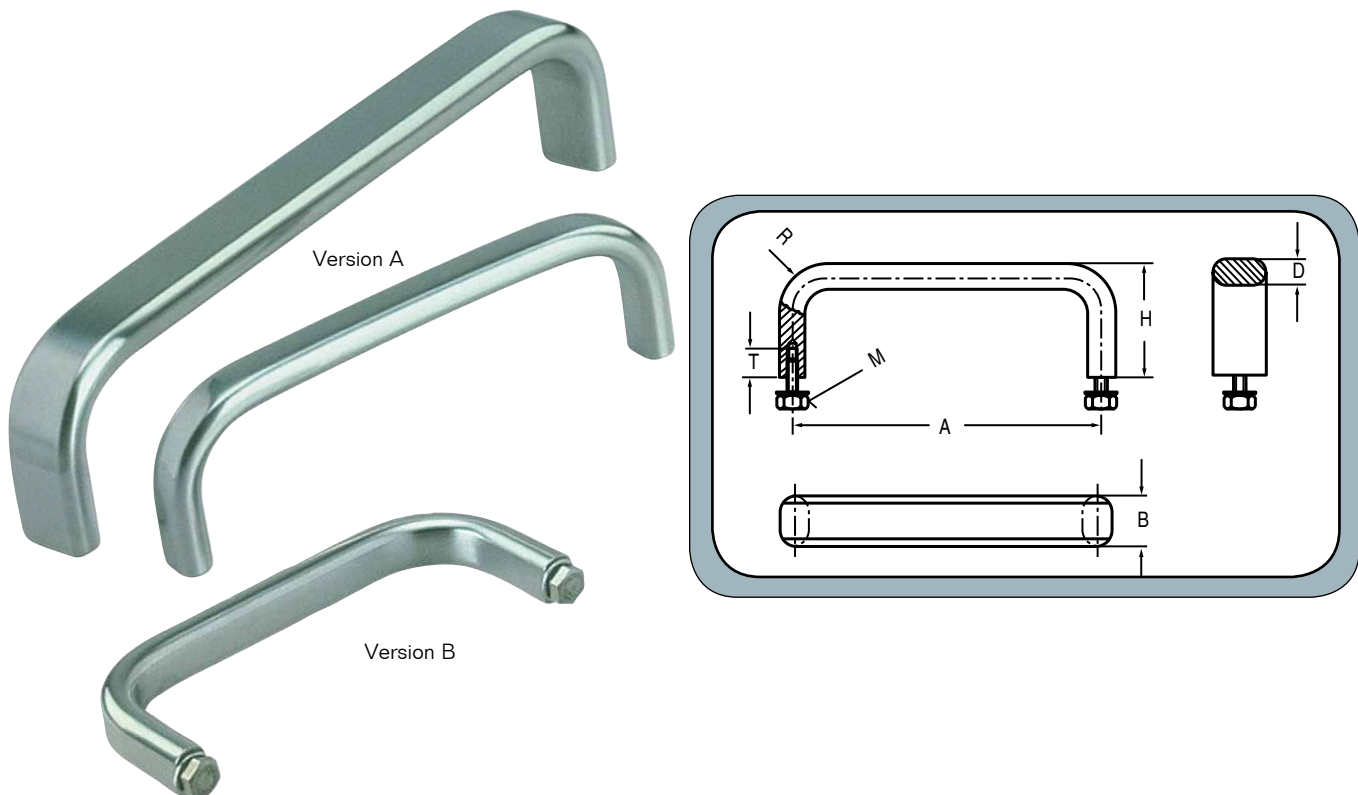

Narrow Version								
B	A	Version A	Version B	M	T	H	D	R
12	100	EF-12.100.31	EF-12.100.36	M5 x 10	10	40	8	22
	120	EF-12.120.31	EF-12.120.36					
	150	EF-12.150.31	EF-12.150.36					
	180	EF-12.180.31	EF-12.180.36					
	250	EF-12.250.31	EF-12.250.36					
	350	EF-12.350.31	EF-12.350.36					
Wide Version								
19.5	100	EF-19.100.31	EF-19.100.36	M6 x 12	12	45	10	24
	120	EF-19.120.31	EF-19.120.36					
	150	EF-19.150.31	EF-19.150.36					
	180	EF-19.180.31	EF-19.180.36					
	250	EF-19.250.31	EF-19.250.36					
	350	EF-19.350.31	EF-19.350.36					

All dimensions in metric

# Round Bar Steel MK Series

The collapsible instrument handle series MK is supplied in two different versions: Version A is precision ground and chromium plated for a mirror finish. Version B is the same as Version A, with an added smooth plastic coated grip ledge.

The MK Series is made of round bar steel. Design features include spring-arrestment in both end positions and a stress capacity to 1,000 N per pari due to one-piece shank. Supplied complete with galvanized washers and nuts.

All dimensions are shown in mm. All dimensions and thread sizes are available in English units.

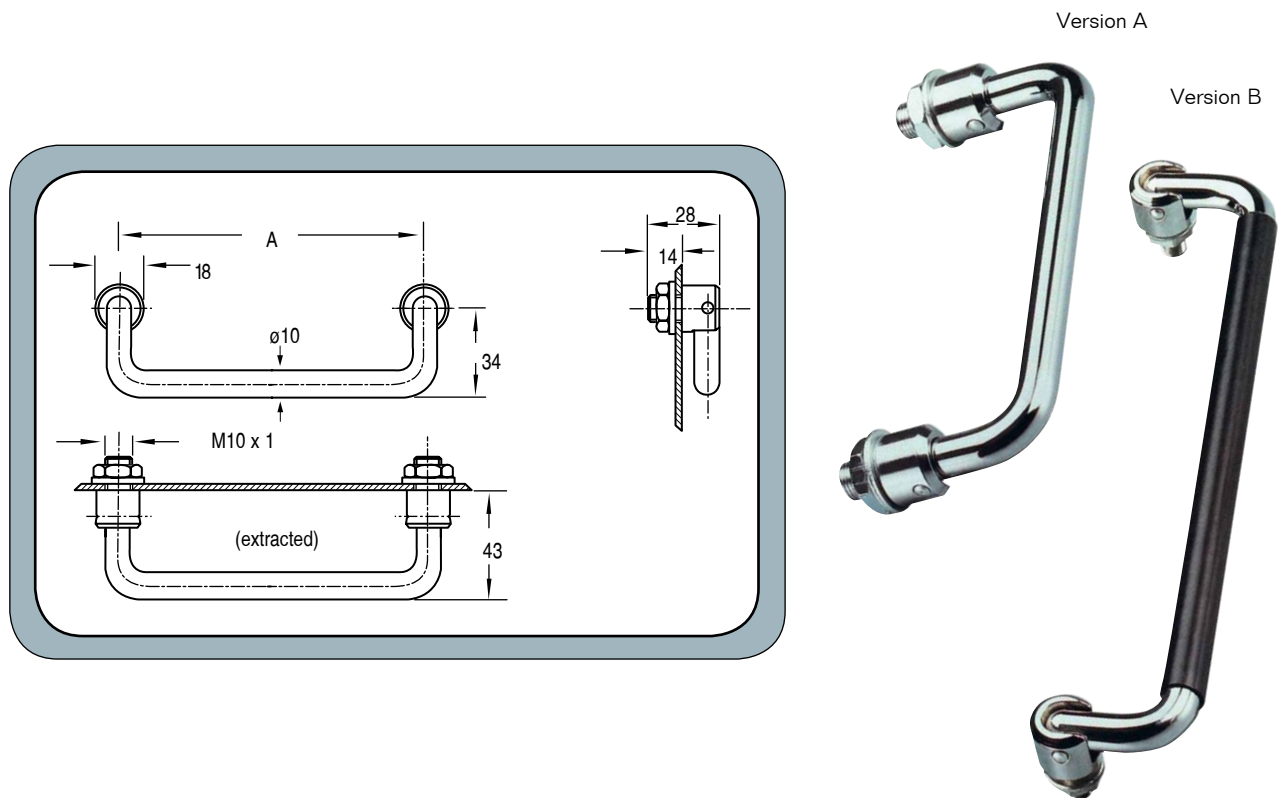

A	Version A Part No.	Version B Part No.
100	MK-10.100.22	MK-10.100.23
120	MK-10.120.22	MK-10.120.23
180	MK-10.180.22	MK-10.180.23

All dimensions in metric

# Multipurpose RS Series

Variable handle series design in two model dimensions for machine and installation construction; particularly suitable for wide spacing between screw-on positions.

Handle shanks made of glass bead reinforced, nylon 6, black, semi-matte with a satin finish. Connecting tubes made of aluminum.

The handle shank RS-20 is provided with four clamping bars and the handle shank RS-30 with two triangular PVC profiles inside of the handle shank to prevent the tube from spinning.

Available in three versions: Version A is a connecting tube ground and anodized in natural; Version B is a connecting tube with a grooved plastic cover; and Version C is a connecting tube black powder coated with a satin finish.

RS-20 includes black galvanized hexagon socket head cap screws M8 x 30, galvanized nuts, and washers. RS-30 also includes screws M10 x 45.

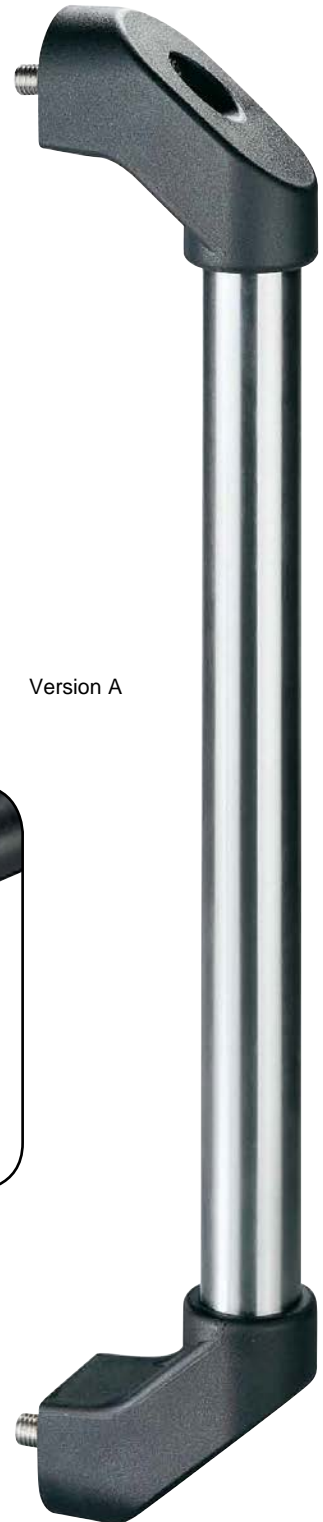

Version A



Version B



Version C

# Multipurpose RS Series

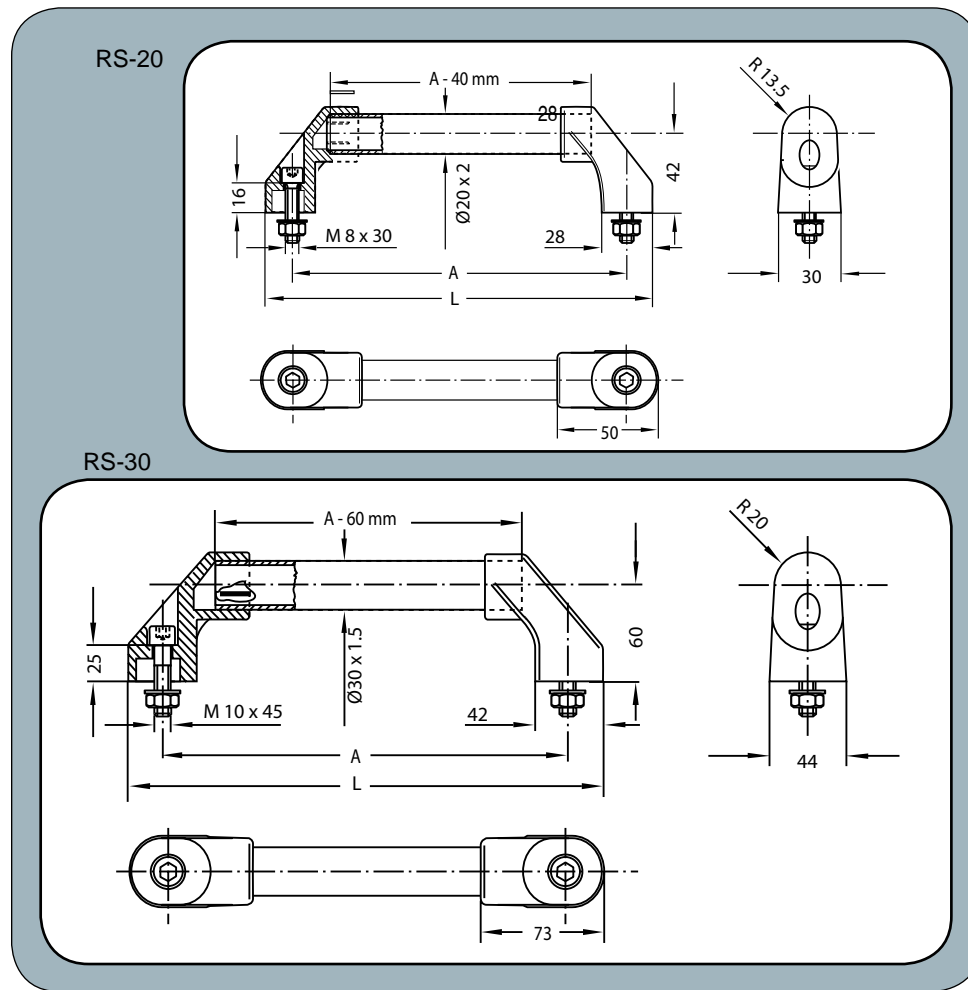

## Single Components Item

	Type RS-20 Part No.	Type RS-30 Part No.
Handle shank, 1 piece, with mounting material	RS-20.000.84	RS-30.000.84
Handle shank, 1 piece, without mounting material	RS-20.0WS.84	RS-30.0WS.84
Connecting tube, 1m, Version A	RS-20.001.01	RS-30.001.01

A	Type RS-20				Type RS-30			
	Version A Part No.	Version B Part No.	Version C Part No.	L	Version A Part No.	Version B Part No.	Version C Part No.	L
180	RS-20.180.62	RS-20.180.63	RS-20.180.64	210	-	-	-	-
200	RS-20.200.62	RS-20.200.63	RS-20.200.64	230	-	-	-	-
250	RS-20.250.62	RS-20.250.63	RS-20.250.64	280	RS-30.250.62	RS-30.250.63	RS-30.250.64	294
300	RS-20.300.62	RS-20.300.63	RS-20.300.64	330	RS-30.300.62	RS-30.300.63	RS-30.300.64	344
350	RS-20.350.62	RS-20.350.63	RS-20.350.64	380	RS-30.350.62	RS-30.350.63	RS-30.350.64	394
400	RS-20.400.62	RS-20.400.63	RS-20.400.64	430	RS-30.400.62	RS-30.400.63	RS-30.400.64	444
500	RS-20.500.62	RS-20.500.63	RS-20.500.64	530	RS-30.500.62	RS-30.500.63	RS-30.500.64	544
600	RS-20.600.62	RS-20.600.63	RS-20.600.64	630	RS-30.600.62	RS-30.600.63	RS-30.600.64	644

All dimensions in metric

# Multipurpose UG-01 Series

The common characteristic of the UG Series handles is their universal usability. They are assembled by fitting the grip ledge to the two elbow side sections. Depending on the degree of stress they must withstand, the elbow sections can be selected with or without steel reinforcement.

Grip ledge made of aluminum tubing; handle shanks made of glass bead reinforced, black nylon, semi-matte. The grip ledge is anodized with a matte finish in natural or black.

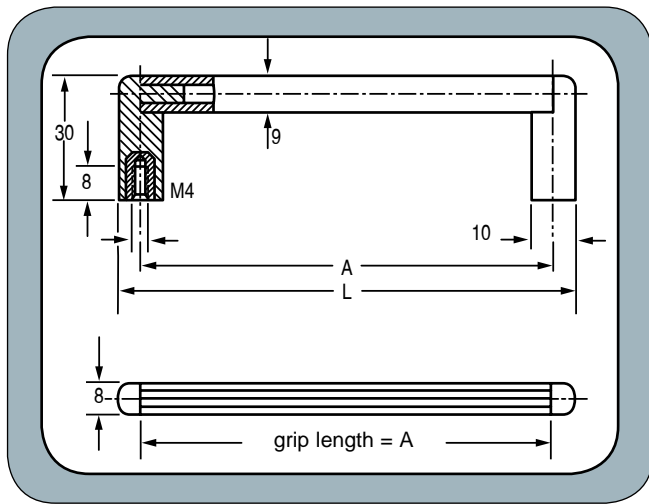

Single Components	Part No.
Handle Shank	UG-01.000.84
Grip Ledge, Natural	UG-01.001.01
Grip Ledge, Black	UG-01.001.04

A	L	Grip Ledge Natural Part No.	Grip Ledge Black Part No.
32	42	UG-01.032.01	UG-01.032.04
55	65	UG-01.055.01	UG-01.055.04
62	72	UG-01.062.01	UG-01.062.04
86	96	UG-01.086.01	UG-01.086.04
88	98	UG-01.088.01	UG-01.088.04
90	100	UG-01.090.01	UG-01.090.04
120	130	UG-01.120.01	UG-01.120.04
134	144	UG-01.134.01	UG-01.134.04

All dimensions in metric

# UG-02, UG-03, & UG-04 Series

For small appliances, front panels, and similar applications. Ledge and shank are matchable as fitting components.

The UG-02 has a brass threaded insert with a stress resistance of 200 N per handle. Grip ledge made of aluminum tubing; handle shanks made of glass bead reinforced, black nylon, semi-matte. The grip ledge is anodized with a matte finish in natural or black. The UG-03 has a galvanized full steel core and a stress resistance of 200 N per handle. Handle ledge made of aluminum special section tube, matte finish, anodized in natural or black. Handle shank of glass bead reinforced nylon with a satin finish and brass threaded insert.

The UG-04 has a screw-attachment from in front, steel plate reinforcement and stress resistance of 500 N per handle. Scope of supply includes glossy nickel-plated screws with hexagon socket M5 x 45 and galvanized, self-locking ratchet nuts. Supplied unassembled.

Other handle lengths available upon request.



# UG-02, UG-03, & UG-04 Series

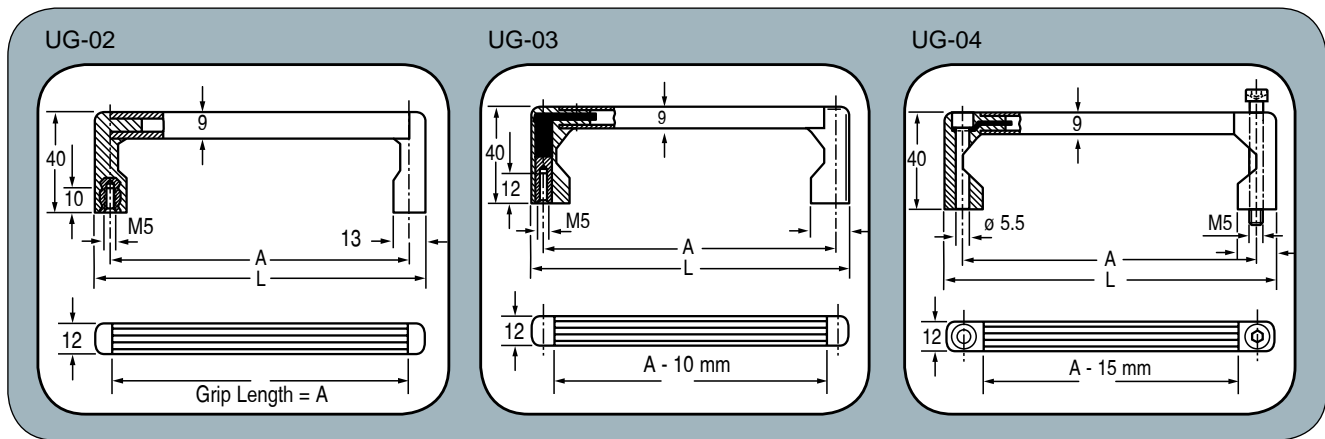

## Single Components

	Part No.
Handle shank, 1 piece	UG-02.000.84
	UG-03.000.84
	UG-04.000.84
Grip ledge, 1m, natural	UG-RS-001.01
Grip ledge, 1m, black	UG-RS-001.04

A	Color of Grip Edge	Type UG-02 Part No.	L	Type UG-03 Part No.	L	Type UG-04 Part No.	L
55	Natural	UG-02.055.01	69	UG-03.055.01	65	UG-04.055.01	70
	Black	UG-02.055.04	69	UG-03.055.04	65	UG-04.055.04	70
88	Natural	UG-02.088.01	102	UG-03.088.01	98	UG-04.088.01	103
	Black	UG-02.088.04	102	UG-03.088.04	98	UG-04.088.04	103
100	Natural	UG-02.100.01	114	UG-03.100.01	110	UG-04.100.01	115
	Black	UG-02.100.04	114	UG-03.100.04	110	UG-04.100.04	115
120	Natural	UG-02.120.01	134	UG-03.120.01	130	UG-04.120.01	135
	Black	UG-02.120.04	134	UG-03.120.04	130	UG-04.120.04	135
180	Natural	UG-02.180.01	194	UG-03.180.01	190	UG-04.180.01	195
	Black	UG-02.180.04	194	UG-03.180.04	190	UG-04.180.04	195
235	Natural	UG-02.235.01	249	UG-03.235.01	245	UG-04.235.01	250
	Black	UG-02.235.04	249	UG-03.235.04	245	UG-04.235.04	250

L	Grip Edge	UG-02 Part No.	A	UG-03 Part No.	A	UG-04 Part No.	A
43	Natural	UG-02.029.01	29	-	-	-	-
	Black	UG-02.029.04	29	-	-	-	-
87.5	Natural	UG-02.073.01	73.5	UG-03.077.01	77.5	UG-04.072.01	72.5
	Black	UG-02.073.04	73.5	UG-03.077.04	77.5	UG-04.072.04	72.5
132	Natural	UG-02.118.01	118	UG-03.122.01	122	UG-04.117.01	117
	Black	UG-02.118.04	118	UG-03.122.04	122	UG-04.117.04	117
176.5	Natural	UG-02.162.01	162.5	UG-03.166.01	166.5	UG-04.161.01	161.5
	Black	UG-02.162.04	162.5	UG-03.166.04	166.5	UG-04.161.04	161.5

All dimensions in metric

# Multipurpose UG-05

Bolt-together handle type for any hole spacing required.

Solid aluminum handle cross rail made of section aluminum. Handle arms made of glass bead reinforced nylon with black, semi-matte finish and screw retaining facilities. Assembled by bolting from the top through the cross rail, providing a load capacity of up to 1,000 N per handle.

Grip ledge anodized in natural or black with a matte finish. U-shaped grips also available in a silver metallic finish.

Includes nickel-plated hexagon head cap screws with hexagon sockets M5 x 45 and zinc plated self-locking nuts.

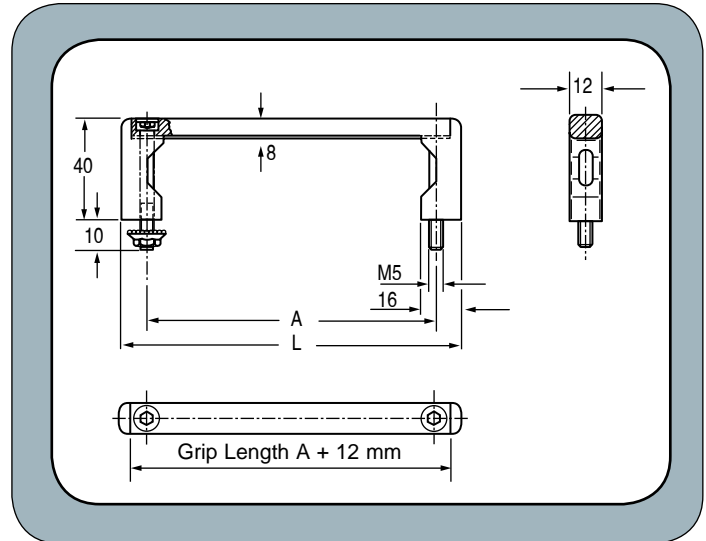

A	L	With Natural Aluminum Ledge Part No.	With Black Aluminum Ledge Part No.
25	45	UG-05.025.01	UG-05.025.04
55	75	UG-05.055.01	UG-05.055.04
88	108	UG-05.088.01	UG-05.088.04
100	120	UG-05.100.01	UG-05.100.04
120	140	UG-05.120.01	UG-05.120.04
180	200	UG-05.180.01	UG-05.180.04
235	255	UG-05.235.01	UG-05.235.04

All dimensions in metric



# Extension Legs GZ

GZ extension legs are constructed for high stress, where safety (from collapse, among other concerns) is of the utmost importance.

Metal components of die-cast zinc. Locking bar of polyamide. Rubber feet.

Base and frame light grey or black satin finish enamel.

Overturn stop provided by use of Allen screws or nuts for installation (screws and nuts M4.) Extension legs are self-locking in both the extended and collapsed positions. Extension lock by means of a plastic bar prevents leg collapse due to accidental knocks. Slide-proof rubber feet guarantee reliable stationary position of the instrument, even on slippery floors, in both the extended and collapsed positions.

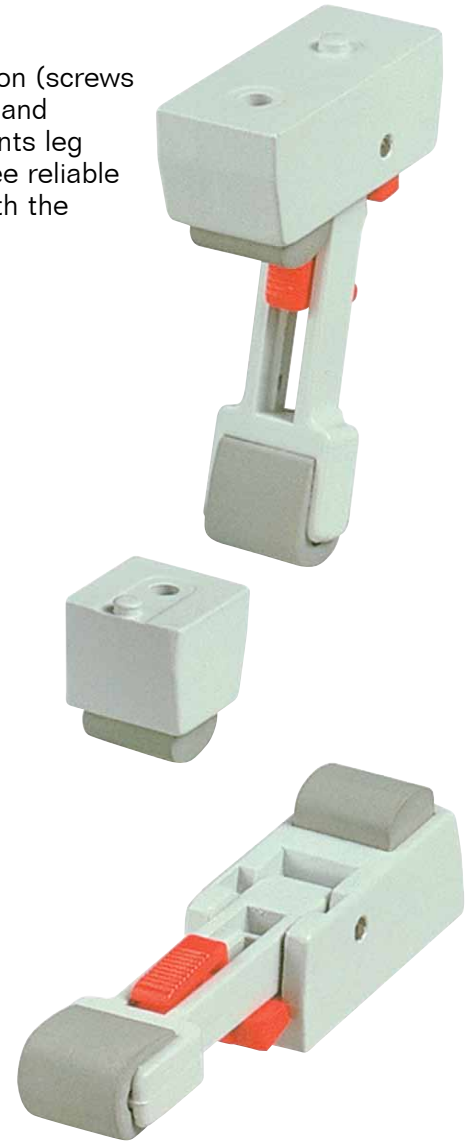
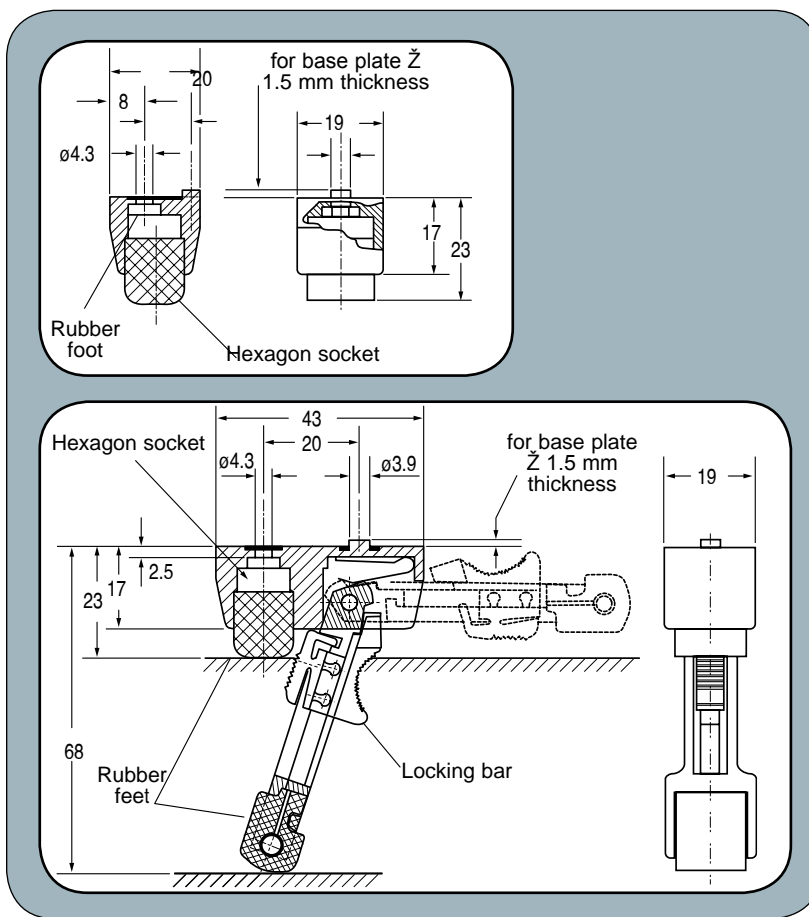

	Light Grey Part No.	Black Part No.
Leg with Lift Lever	GZ-23.068.52	GZ-23.068.44
Leg without Lift Lever	GS-23.000.52	GS-23.000.44

All dimensions in metric

# Casing Feet GK



Glass fiber reinforced polyamide, black satin finish. Base and frame light grey or black satin finish enamel. Extension leg with snap-in lock in both positions. Slide-proof rubber feet for safety, even in extended position. 4.8  $\phi$  through bore for screw attachment. Supplied in sets (see table), including sheet metal screws with oval cross-slotted head. Eight 3.0 x 9.5

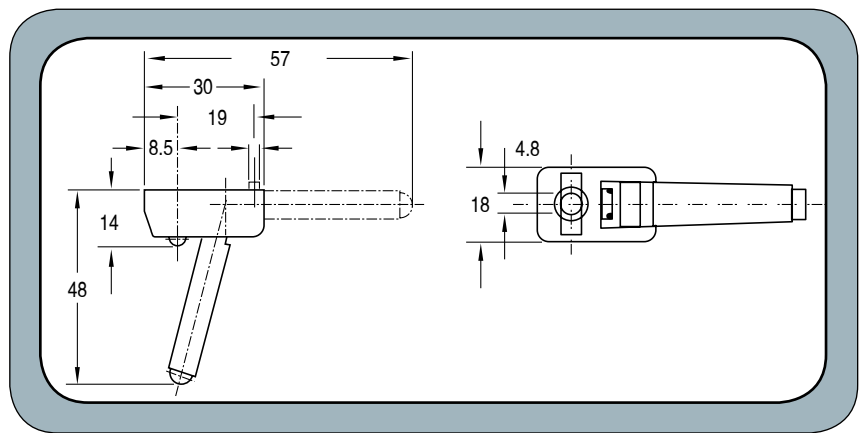

Supply Unit	Part No.
Set: 2 pcs. with lift lever, 2 pcs. without lift lever, incl. screws	GK-14.048.84S
Set: 4 pcs. without tilt bracket, incl. screws	GK-14.000.84S

All dimensions in metric

# Casing Feet GG

Type A PVC black, type B and C natural black rubber. Type A and B for screw assembly; Type C as a pluggable foot for base plates of 2.0 - 3.0 mm thickness.

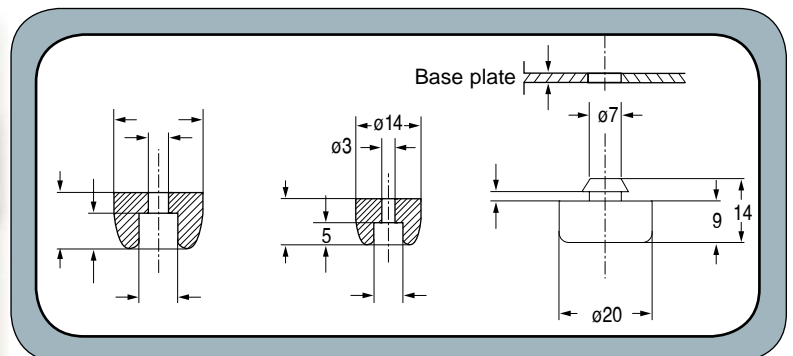

	Type A	Type B	Type C
Part No.	GG-20.012.84	GG-14.010.84	GG-20.009.84

All dimensions in metric

# Clean Line Handle Series R1 and S1

Clean line design suitable for the medical and food processing industries. Cut profiled Aluminium AlMgSi 0.5. Vibratory ground and powder coated in grey white. Special color versions available on request.



	A	L	Part no.
R1	55	67	R1-12.055.9002
	88	100	R1-12.088.9002
	120	132	R1-12.120.9002
	180	192	R1-12.180.9002
	235	247	R1-12.235.9002
S1	25	40	S1-12.025.9002
	55	69	S1-12.055.9002
	88	102	S1-12.088.9002
	120	134	S1-12.120.9002
	180	194	S1-12.180.9002
	235	249	S1-12.235.9002

All dimensions in metric.

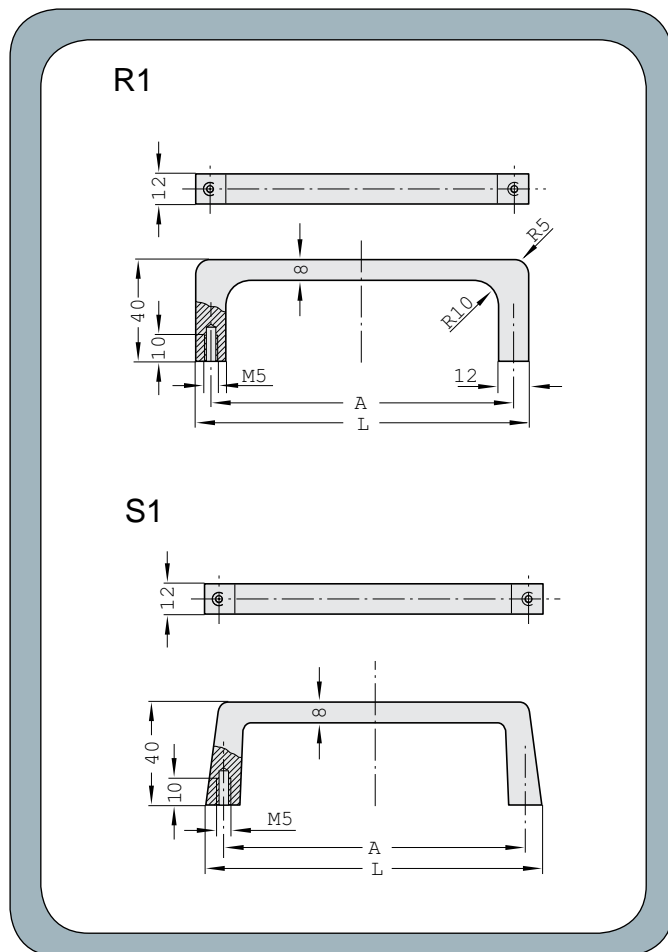

# Clean Line Handle Series OA & MF

Clean line design suitable for the medical and food processing industries. Flat-oval profiled aluminium AlMgSi 0.5. Vibratory ground and powder-coated in grey white.

Special color versions available on request.



## OA

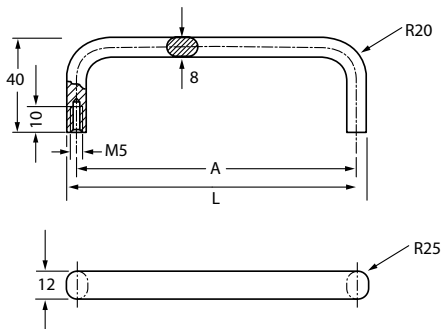

	A	Part no.	
OA	55	OA-12.055.9002	
	88	OA-12.088.9002	
	100	OA-12.100.9002	
	120	OA-12.120.9002	
	180	OA-12.180.9002	
	200	OA-12.200.9002	
	235	OA-12.235.9002	
	250	OA-12.250.9002	

## MF

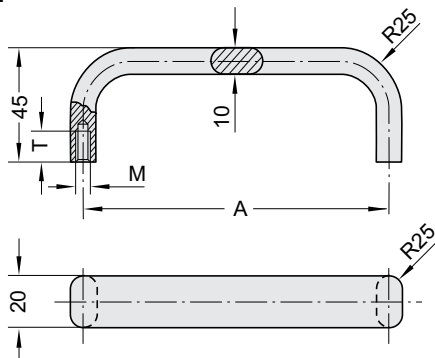

			M	T
MF	120	MF-20.120.9002	5	10
	140	MF-20.140.9002		
	180	MF-20.180.9002		
	200	MF-20.200.9002		
	350	MF-20.350.9002	6	12

All dimensions in metric.

# Clean Line Handle Series MO



Clean line design suitable for the medical and food processing industries. Oval profiled aluminium AlMgSi 0.5. Vibratory ground and powder coated in grey white.

Special color versions available on request.

	A	Part no.
MO-20	100	MO-20.100.9002
	128	MO-20.128.9002
	160	MO-20.160.9002
MO-26	140	MO-26.140.9002
	160	MO-26.160.9002
	180	MO-26.180.9002
	192	MO-26.192.9002
	350	MO-26.350.9002

All dimensions in metric.

MO-20

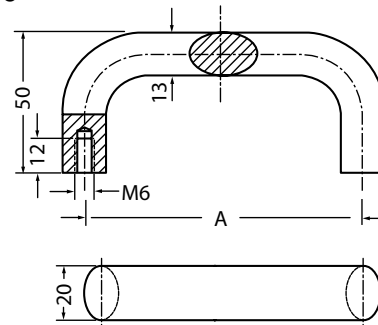

MO-26

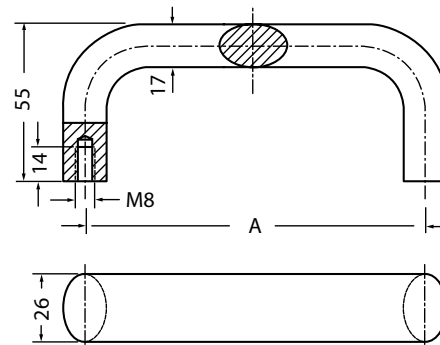

# Clean Line Handle Series SG

Clean line design suitable for the medical and food processing industries. The SG tray handle can be supplied in any length. Handle tray made of aluminium section, varnished in grey white. Side end caps made of PA6 in a similar color shade.

Very simple installation. Does not require screws for metal thicknesses of 1-2.5 mm. Two rubber inserts guarantee tight and secure installation.

Two cross-slotted grooves for M 4-screws juxtaposed by 90° provide firm connection, or they may be used as mounting aids for installation elements.

Mounting: After insertion of the bottom rubber insert, the two end finials must be pushed on to the tray. Next the handle must be pressed over the lower edge of the mounting cutout at a 45° angle. Holding the handle against the housing panel, now the second rubber insert is pushed into the upper groove (see illustration below).

All handle lengths and color shades are available on request.

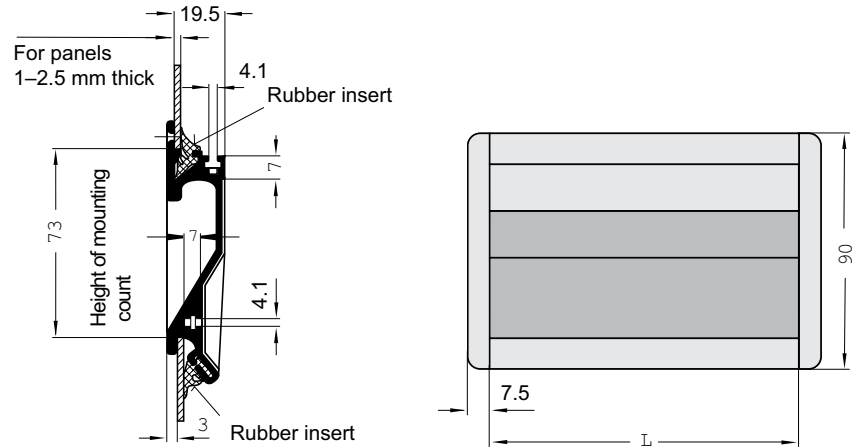

## Mounting

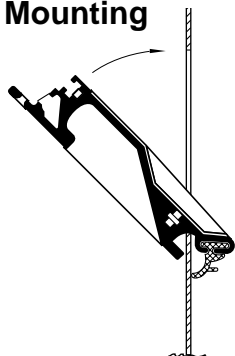

## Mounting cutout

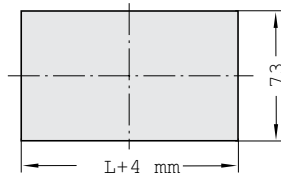

L	Part no.	Mounting cutout
100	SG-73.100.9002	104 x 73
118	SG-73.118.9002	122 x 73
167	SG-73.167.9002	171 x 73

All dimensions in metric.

# Clean Line Knob Series BM

## Knurled Knob BM

Thermo-setting plastic series especially for food preparation and other hygienic areas.

Thermo-setting plastic MF 152 (melamine resin reinforced with cellulose); stainless steel threaded bush and bolt, material 1.4305.

Deburred and highly polished; color shade signal white similar to RAL 9003.

Temperature stability:  
From  $-40^{\circ}\text{C}$  to  $+150^{\circ}\text{C}$ .

Other colors available on request.



### with inside thread

Type	D	Part no.	M	T	H	d
BM-AI	12	BM-AI.412.9003	4	9	13.5	10
	15	BM-AI.515.9003	5	9	13.5	12
BM-BI	17	BM-BI-617.9003	6	9	22	12

### with threaded bolt

Type	D	Part no.	M	L	H	d
BM-BZ	17	BM-BZ.517.9003	5	15	22	12
	17	BM-BZ.617.9003	6	20	22	12

All dimensions in metric.

BM-AI

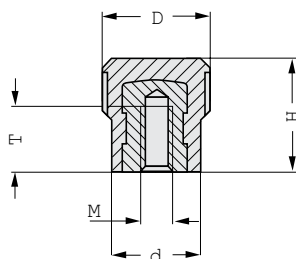

BM-BI

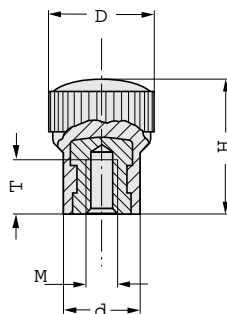

BM-BZ

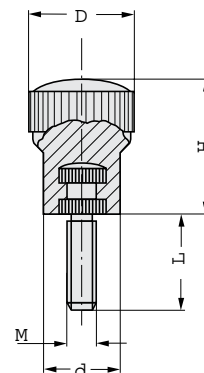

# Clean Line Knob Series BT

## Three-Arm Knob BT

Thermoset plastic series especially for food preparation and other hygienic areas.

Thermo-set plastic MF 152 (melamine resin reinforced with cellulose); stainless steel threaded bush and bolt, material 1.4305

Deburred and highly polished; color shade signal white similar to RAL 9003.

Temperature stability: from  $-40^{\circ}\text{C}$  to  $+150^{\circ}\text{C}$ .

Other colors available on request.

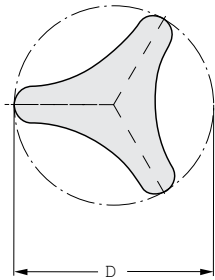

### BT-GZ with threaded bolt

D	Part no.	M	L	H	K	d
40	BT-GZ.040.9003	6	20	24	13.5	13.5
50	BT-GZ.050.9003	8	20	28	14	17.5
62	BT-GZ.062.9003	10	30	34	17	21.5

### BT-IG with inside thread

D	Part no.	M	T	H	K	d
40	BT-IG.040.9003	6	9	24	13.5	13.5
50	BT-IG.050.9003	8	13	28	14	17.5
62	BT-IG.062.9003	10	13	34	17	21.5

All dimensions in metric.

### BT-GZ

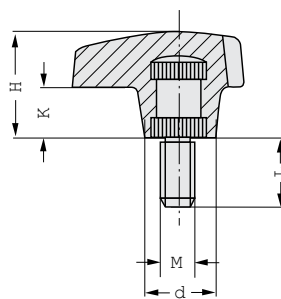

### BT-IG

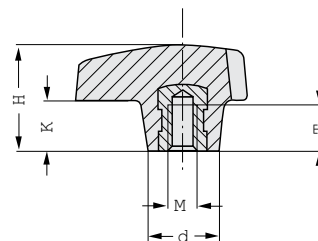



# Clean Line Knob Series BL



## Knob Handle BL

Thermoset plastic series especially for food preparation and other hygienic areas.

Thermoset plastic MF 152 (melamine resin reinforced with cellulose); stainless steel threaded bush and bolt, material 1.4305.

Deburred and highly polished; color shade signal white similar to RAL 9003.

Temperature stability: From  $-40^{\circ}\text{C}$  to  $+150^{\circ}\text{C}$ .

Other colors (and versions with knurling all around) available on request.

### BL-IG with inside thread

D	Part no.	M	T	H	d
25	BL-IG.025.9003	6	20	25	12
30	BL-IG.030.9003	6	20	30	14
35	BL-IG.035.9003	8	20	35	16
40	BL-IG.040.9003	10	30	40	18
45	BL-IG.045.9003	10	30	45	20

### BL-GZ with threaded bolt

D	Part no.	M	L	H	d
25	BL-GZ.025.9003	6	9	25	12
30	BL-GZ.030.9003	8	13	30	14
35	BL-GZ.035.9003	8	13	35	16
40	BL-GZ.040.9003	10	13	40	18
45	BL-GZ.045.9003	10	13	45	20

All dimensions in metric.

### BL-GZ

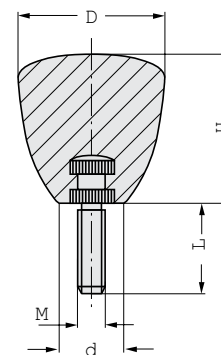

### BL-IG

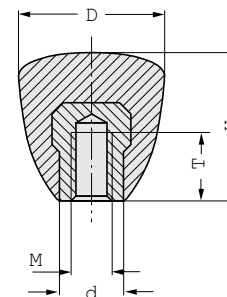

# Product Part Index



PRODUCT PART INDEX

PART #	PAGE	PART #	PAGE	PART #	PAGE	PART #	PAGE	PART #	PAGE	PART #	PAGE	PART #	PAGE		
0012	32	0230-A	53	1204	31	2110	33	2840	13	3086	9	4107	35	8510	52
0013	32	0231	53	1206	31	2150	33	2841	16	3087	11	4108	35	8540	52
0014	32	0240	53	1208	31	2300	33	2850	15	3088	10	4109	35	AM	71
0016	32	0240-B	53	1210	32	2310	33	2851	15	3089	10	4200	23	BM	87
0017	32	0241	53	1212	34	2350	33	2855	15	3090	10	4201	23	BT	88
0018	39	0245	53	1214	32	2405	49	2860	15	3091	10	4202	23	EC	56
0019	39	0250	54	1216	32	2415	49	2870	15	3092	10	4210	23	EF	73
0020	40	0251	54	1221	26	2425	49	2880	53	3093	10	4211	23	GG	82
0025	38	0260	53	1226	26	2430	48	2890	15	3094	10	4212	23	GK	82
0030	38	0260-K	53	1227	26	2432	48	2960	53	3095	43	4230	23	GS	47
0033	38	0261	53	1230	26	2435	49	2965	18	3096	11	4231	23	GZ	81
0035	38	0280	53	1231	26	2440	48	2968	17	3097	11	4232	23	KG	64
0036	40	0281	53	1322	34	2442	48	2971	14	3098	10	4240	23	KK	60
0040	40	0630	51	1326	34	2445	49	2972	17	3099	10	4241	23	KM	58
0042	40	0635	50	1330	34	2450	48	2974	17	3100	43	4242	23	KS	59
0044	38	0640	51	1400	32	2452	48	2978	17	3120	43	4300	19	MA	61
0045	38	0641	51	1450	31	2465	49	2980	14	3140	43	4302	19	MF	71,84
0046	40	0645	51	1470	32	2470	48	2981	14	3200	43	4310	19	MK	74
0050	40	0660	50	1475	31	2472	48	2983	17	3220	43	4312	19	MO	69,85
0055	38	0670	50	1500	32	2480	48	2988	17	3230	43	4320	19	MS	55
0056	38	0680	50	1504	34	2482	48	2990	14	3235	43	4322	19	OA	68,84
0057	40	0690	45	1505	33	2510	11	3000	18	3240	42	4500	46	R	63
0061	40	0691	45	1506	33	2520	11	3001	43	3245	42	4510	51	R1	83
0065	40	0692	45	1510	32	2530	11	3002	43	3250	42	4520	51	RA	67
0066	40	0693	45	1520	32	2670	13	3003	43	3255	42	4525	51	RG	47
0070	40	0694	45	1550	32	2700	22	3004	43	3260	42	4555	46	RR	70
0071	40	0696	45	1555	33	2710	22	3005	43	3270	42	4560	46	RS	75-6
0073	41	0697	45	1560	33	2715	22	3006	43	3275	42	4570	46	S	66
0075	41	0698	44	1600	34	2720	22	3008	18	3280	42	4580	46	S1	83
0076	41	0699	36	1610	34	2730	22	3009	18	3290	42	4590	46	SG	86
0077	41	0700	44	1620	34	2745	22	3015	18	3295	42	4901	38	SK	62,65
0078	42	0710	44	1630	34	2750	20	3018	18	3340	24	5000	41	ST	72
0079	42	0720	44	1640	34	2751	20	3020	43	3341	24	5089	42	UG	77-80
0080	41	0730	44	1650	34	2752	20	3022	12	3350	24	5149	36		
0085	41	1100	29	1660	34	2760	20	3025	12	3351	24	5208	38		
0086	41	1104	27	1665	34	2770	20	3030	21	3370	24	5247	18		
0090	41	1105	29	1680	34	2771	20	3035	12	3371	24	5451	46		
0091	41	1106	27	1700	31	2772	20	3036	12	3510	12	5548	51		
0092	41	1107	27	1770	22	2780	20	3038	12	3512	12	5582	50		
0099	36	1108	27	1775	36	2790	20	3040	12	3702	42	5676	18		
0110	32	1109	27	1900	31	2791	20	3041	12	3704	42	5682	50		
0112	32	1110	29	1910	34	2792	20	3045	12	4000	52	5715	45		
0115	32	1116	27	1913	34	2800	13	3050	21	4005	52	5754	42		
0125	36	1117	27	1914	31	2805	16	3055	21	4010	52	5755	42		
0130	37	1118	27	1919	32	2810	13	3065	21	4020	52	7094	22		
0135	37	1118-A	27	1920	34	2813	13	3070	15	4030	52	7105	14		
0140	37	1120	29	1922	31	2815	13	3071	15	4040	52	7106	14		
0145	37	1140	29	1925	34	2817	13	3072	15	4050	52	7173	14		
0150	37	1145	29	1930	34	2820	13	3073	15	4060	52	8000	33		
0155	37	1150	29	1940	34	2821	16	3075	15	4070	52	8005	33		
0210-A	53	1155	29	2020	11	2822	13	3076	15	4075	36	8010	33		
0211	53	1161	27	2022	11	2823	16	3077	15	4080	52	8070	30		
0220	53	1162	27	2030	10	2825	13	3078	15	4100	24	8072	34		
0220-A	53	1163	27	2031	10	2829	16	3080	21	4101	24	8090	30		
0220-B	53	1164	27	2032	10	2830	13	3081	11	4102	24	8125	30		
0221	53	1165	27	2033	10	2831	13	3082	11	4103	24	8175	30		
0225	54	1167	27	2034	10	2832	16	3083	11	4104	35	8225	30		
0226	54	1200	31	2084	11	2835	13	3084	11	4105	35	8450	30		
0230	53	1202	31	2100	33	2837	13	3085	10	4106	35	8460	30		

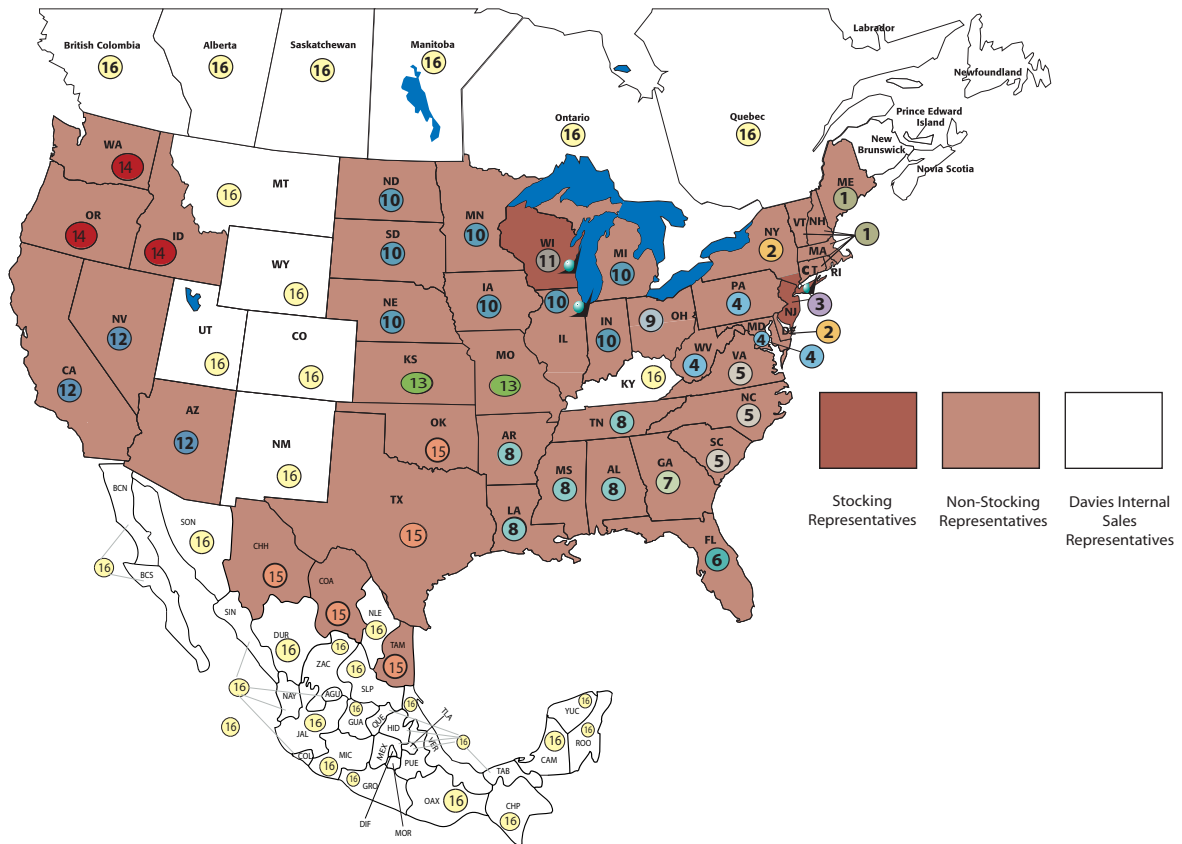

# Sales Representative Listing

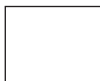

 Stocking Representatives  
 Non-Stocking Representatives  
 Davies Internal Sales Representatives

- 1** Connecticut • Maine  
New Hampshire • Vermont  
Rhode Island • Massachusetts  
**Bengal Sales Associates**  
150 Speen Street  
Framingham, MA 01701  
508-872-1135  
Fax: 508-872-2024
- 2** Delaware • New Jersey (Non-Metro) • New York (Upstate)  
**Lee S. Johnson Associates**  
557 East High Street  
Pottstown, PA 19464  
877-634-7377  
Fax: 866-329-5752
- 3** New Jersey (North) • New York (Metro)  
**Rywel Sales Inc.**  
29 Sunset Boulevard  
Wading River, NY 11792  
631-929-4884  
Fax: 631-929-5627
- 4** Pennsylvania • Maryland  
West Virginia  
**E. W. Hamlin & Associates**  
P.O. Box 22382  
Akron, OH 44302  
330-673-9592  
Fax: 330-673-9593
- 5** North Carolina  
South Carolina • Virginia  
**Clevenger & Associates**  
6618 Providence Lane West  
Charlotte, NC 28226  
704-236-6872  
Fax: 704-341-7189
- 6** Florida  
**Meyer Marketing Group Inc.**  
1235 Candlewood Drive  
Lakeland, FL 33813  
863-648-1347  
Fax: 863-644-3062
- 7** Georgia  
**The Raynor Group**  
123 Quail Trail  
Fitzgerald, GA 31750  
229-423-4294  
Cell: 229-424-8242  
Fax: 229-423-4294
- 8** Alabama • Arkansas • Louisiana  
Mississippi • Tennessee  
**L. E. Offutt Co., Inc.**  
1150 Montevallo Road SW  
Leeds, AL 35094  
205-699-3524  
Fax: 205-699-3525  
Branch: P.O. Box 54  
Madden, MS 39109  
601-298-1221  
Fax: 601-298-1209  
Branch: 338 Greystone Terrace  
Athens, GA 30606  
706-552-0415  
Fax 706-552-0415
- 9** Ohio  
**Foley Company**  
11620 Old State Road  
Chardon, OH 44024  
440-286-3334  
Fax: 440-286-9783
- 10** Illinois • Indiana • Iowa  
Michigan • Minnesota  
Nebraska • North Dakota  
South Dakota  
**Wing-Hamlin Company**  
126 North York Rd.  
Elmhurst, IL 60126  
630-279-6161  
Fax: 630-279-6181
- 11** Wisconsin  
**Clague Sales Corporation**  
Thiensville, WI 53092  
122 Green Bay Road  
262-242-5580  
Fax: 262-242-5585
- 12** Arizona • California • Nevada  
**Littrell Sales, Inc.**  
23701 West Sarda Rd.  
Valencia, CA 91355  
661-259-4434  
Fax: 661-259-1170  
Branch: 4238 East Spur Road  
Cave Creek, AZ 85261  
480-473-7191  
Fax: 480-473-7816
- 13** Kansas • Missouri  
**Siena Fastener Inc.**  
11305 Meredith Dr.  
Des Moines, IA 50322  
515-240-2293  
Fax: 612-395-9155
- 14** Alaska • Idaho • Oregon  
Washington  
**ProWest Marketing, Inc.**  
16617 SE 35th Way  
Vancouver, WA 98683  
360-254-2679  
Fax: 360-896-5881
- 15** Oklahoma • Texas  
MEXICO  
Chihuahua • Coahuila • Tamaulipas  
**Technology Components Southwest**  
130 E. Felix Street South  
Ste. 456  
Fort Worth, TX 76115  
817-923-2900  
Fax: 817-923-2910
- 16** Canada • Mexico  
Please Contact  
Davies Molding Main Office