

## Application Note 5533

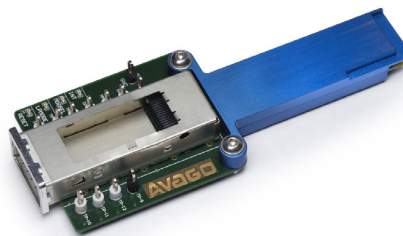

### QSFP+ Extender Board

The QSFP+ extender board was designed to access QSFP+ low speed control signals while a DUT QSFP+ compliant to SFF-8436 is plugged into the target application system such as a network switch and router. TX & RX high speed signals are routed on the board with 50 ohm transmission lines to maintain signal integrity. The extender board is a useful tool for trouble shooting any problems associated with QSFP+'s running in systems.

### I. QSFP+ Extender board description

Top view of the extender board is shown in Figure 1. The extender board has probe pins to monitor the signals shown in Table 1. Blue anodized housing shell supports the extender board with measurement equipment probes hooked up to the probe pins. The housing also helps the extender board to mate the host connector with correct polarity.

The extender board provides two probe pins connected to the circuit GND. The cage on the PCB is isolated from the circuit GND. The blue anodized housing is also isolated from the circuit GND.

LEDs on the extender board indicating probe pin signal levels are available for ResetL, LPMode, ModSelL, IntL, and ModPrsL signals. LEDs turn on when the signal levels are at LVTTTL high level and turn off when the signal levels are at LVTTTL low level.

VccTx, VccRx and Vcc1 probe pins have 100 ohm resistors in between the pins and power supply to protect host power supply from accidental shorting.

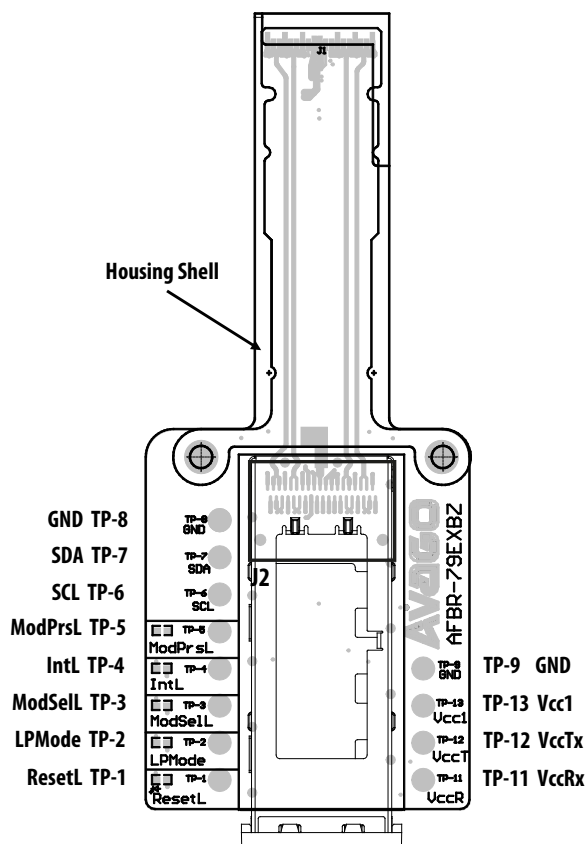

Figure 1. QSFP+ Extender Board Top View

**Table 1. Probe pins on QSFP+ extender board**

Probe Pin #	Signal Name	LED available?	LED ON when	Signal electrical connection on the board
TP-1	ResetL	Yes	ResetL is high	Reset (assert low)
TP-2	LPMode	Yes	LPMode is high	Low power mode
TP-3	ModSelL	Yes	ModSelL is high	Module select (assert Low)
TP-4	IntL	Yes	IntL is high	Interrupt (assert low)
TP-5	ModPrsL	Yes	ModPrsL is high	Module present (assert low)
TP-6	SCL			Two wire serial clock
TP-7	SDA			Two wire serial data
TP-8	GND			Circuit GND
TP-9	GND			Circuit GND
TP-11	VCCR			VccRx via a 100 ohm protection resistor
TP-12	VCCT			VccTx via a 100 ohm protection resistor
TP-13	VCC1			Vcc1 via a 100 ohm protection resistor

## II. How to use AVAGO QSFP+ Extender Board

The QSFP+ Extender Board can be used to measure voltage level and timing of QSFP+ interface signals. Various measurement equipments such as digital volt meter, oscilloscope and logic analyzer can be connected to the extender board probe pins 1 to 13 on Figure 1.

To measure the VccRx voltage, for example, plug the QSFP+ extender board into the application system. Then plug the QSFP+ module into the cage on the extender board. Plug fiber optic cable to the QSFP+ module optical port if necessary. Connect the digital volt meter leads to TP-11 and GND probe pins on the extender board as shown in Figure 2. Read the VccRx voltage from the digital volt meter and check the LEDs on the extender board.

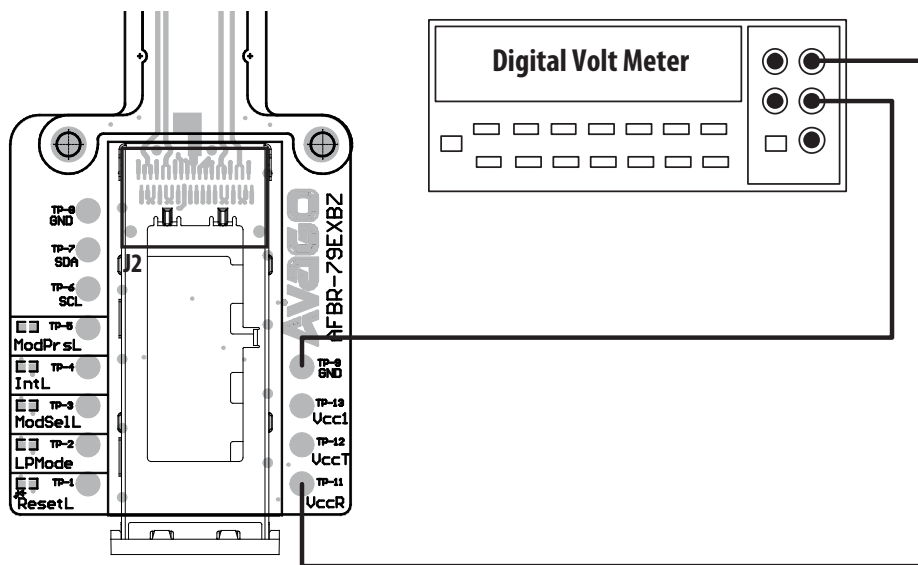

**Figure 2. An example of how to use QSFP+ extender board to measure Rx Vcc voltage**

### III. Extender Board Schematic and Bill of Materials

The QSFP+ Extender Board schematic is shown in Figure 3. Table 2 shows the bill of materials.

**Table 2. Bill of Material**

Components	Foot Print	Quantity	Reference Designator
0.1 uF	0603	3	C-1, C3, C4
22 uF	1210	1	C-2
100 ohm	0603	3	R7, R8, R9
200 ohm	0603	5	R-1, R-4, R-5, R-6, R-7
Tyco Electronics P/N 1761987-9	QSFP Connector	1	J2
LED	0603	5	D1, D2, D3, D4, D5
74LVC06A	SO-14	1	U1
Digi-Key P/N 5012K-ND (white), 5011K-ND (black)		12	TP-1, TP-2, TP-3, TP-4, TP-5, TP-6, TP-7, TP-8, TP-9, TP-11, TP-12, TP-13
Tyco Electronics P/N 1888781-1	QSFP Cage	1	

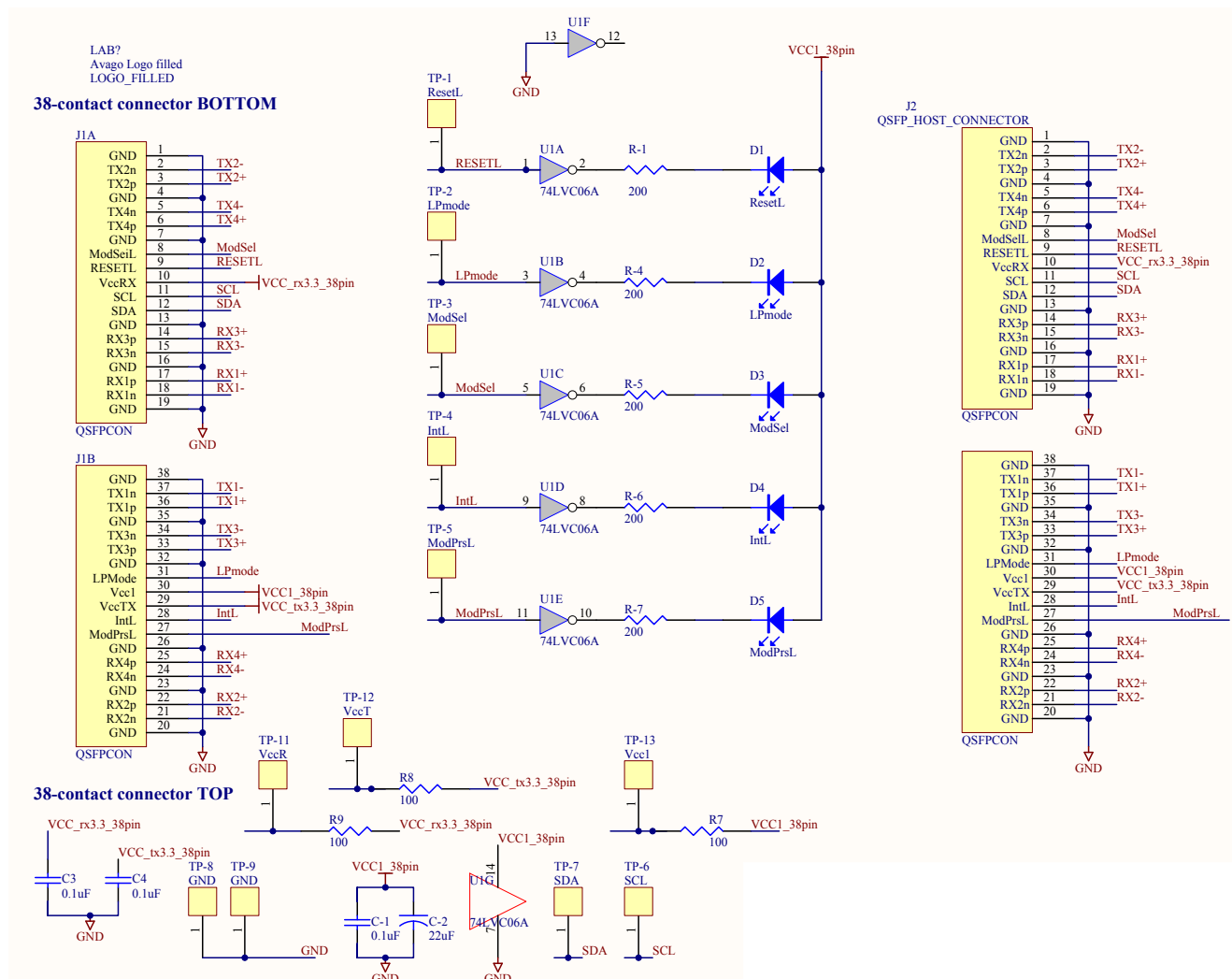

**Figure 3. QSFP+ Extender Board Schematic Diagram**

For product information and a complete list of distributors, please go to our web site: [www.avagotech.com](http://www.avagotech.com)

Avago, Avago Technologies, and the A logo are trademarks of Avago Technologies in the United States and other countries.  
Data subject to change. Copyright © 2005-2013 Avago Technologies. All rights reserved.  
AV02-3230EN - November 26, 2013

