

Table of Contents

Module Circuit Schematic.....	3
Open Source.....	4
License.....	4
Overview.....	4
Technical specifications.....	4
Pinout:.....	5
Legal disclaimer notice.....	6
Developer info.....	6
Datasheet Revision History.....	6

Module Circuit Schematic

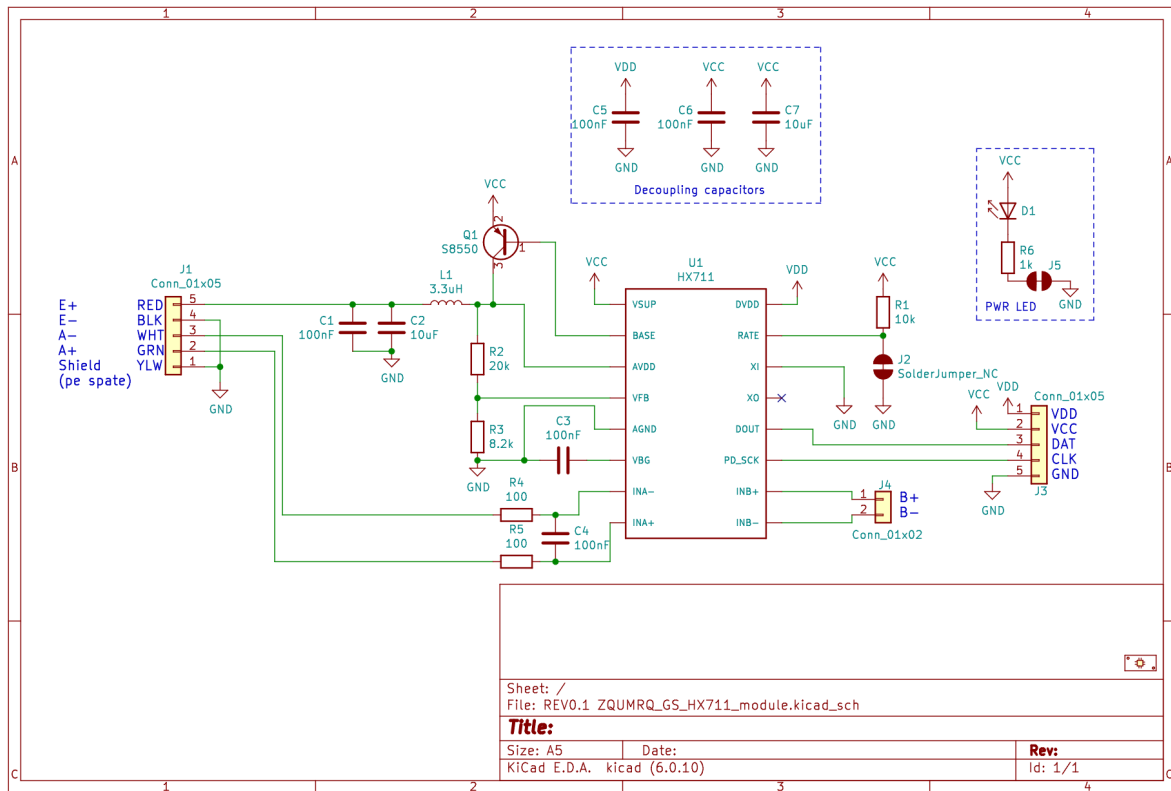

Figure 2: GroundStudio HX711 module schematic circuit [Revision 0.0.1]

Open Source

This is an Open Source project, you can find all the technical documents online:

https://github.com/GroundStudio/GroundStudio_HX711_module

License

All documentation for GroundStudio Marble Pico is released under the [Attribution-ShareAlike 4.0 International \(CC BY-SA 4.0\)](#) license. You are welcome to use this for commercial purposes.

Please consider contributing back to this project or others to help the open-source hardware community continue to thrive and grow!

Overview

The HX711 IC module can be used to communicate with two load cells. Load cells are used to weigh objects both industrially and for smaller weights.

The module is a high-precision, 24-bit one, and communicates with Arduino development boards on a two-wire protocol (clock wire and data wire).

With two products of this type and 4 load cells you can build your own scale.

The presence of the supply voltage is indicated by the "PWR" LED located on the module.

To minimize power consumption, the "PWR" LED can be disconnected using the "Disable PWR LED" jumper located on the back of the pcb.

Also on the back of the pcb you will find a jumper called "Sample rate" with the help of which the transfer frequency of the output data can be controlled. The jumper comes closed by default (10Hz) and can be interrupted using a cutter (the frequency value becomes 80Hz).

Technical specifications

Supply voltage: 2.7V - 5.5V;

Current consumption: 10mA;

ADC resolution: 24 bit;

2 channels;

Differential input;

Pinout:

VCC = is the main power supply (2.7V - 5.5V).

VDD = is connected directly to VCC.

DAT = pin connection for data transfer

CLK = pin connection for the clock signal.

GND = ground connection.

YLW/SHIELD = shield connection (if present, this pin is internally connected to GND).

GRN/A+ = analog positive input for channel A

WHT/A- = analog negative input for channel A

BLK/E- = ground connection for the sensitive element (cell/load sensor).

RED/E+ = analog power supply for the sensitive element (load cell/sensor).

B+ = analog positive input for channel B.

B- = analog negative input for channel B.

Legal disclaimer notice

This development board is considered a subassembly in accordance with FCC CFR Title 47 §15.101(e):

[https://www.ecfr.gov/current/title-47/chapter-I/subchapter-A/part-15/subpart-B/section-15.101#p-15.101\(e\)](https://www.ecfr.gov/current/title-47/chapter-I/subchapter-A/part-15/subpart-B/section-15.101#p-15.101(e))

The device does not have a standalone functionality and does not include an enclosure or power supply.

The device is mainly intended for development and prototyping but it can be integrated into a product. In this case it is the responsibility of the developer/manufacturer to obtain all the necessary certifications.

GroundStudio is a registered trademark of ARDUSHOP SRL:

<https://www.tmdn.org/tmview/#/tmview/detail/EM500000018364087>

Developer info

ARDUSHOP SRL

Addr: Str. Aleea Unirii, Nr. 8, Ap. 7, Loc. Selimbar, Jud. Sibiu, ROMANIA, 557260

e-mail: office@ardushop.ro

Datasheet Revision History

[Revision 1] - Initial version release