

# EC axial fan

with brushless DC motor

Fan housing with guide vanes, Automotive

## ebm-papst Mulfingen GmbH & Co. KG

Bachmühle 2 · D-74673 Mulfingen

Phone +49 7938 81-0

Fax +49 7938 81-110

info1@de.ebmpapst.com

www.ebmpapst.com

Limited partnership · Headquarters Mulfingen

Amtsgericht (court of registration) Stuttgart · HRA 590344

General partner Elektrobau Mulfingen GmbH · Headquarters Mulfingen

Amtsgericht (court of registration) Stuttgart · HRB 590142

## Nominal data

Type	W3G300-ME46-01	
Motor	M3G084-BF	
Nominal voltage	VDC	26
Nominal voltage range	VDC	16 .. 32
Method of obtaining data		fa
Status		prelim.
Speed (rpm)	min <sup>-1</sup>	3000
Power consumption	W	180
Current draw	A	7.0
Min. ambient temperature	°C	-40
Max. ambient temperature	°C	85

ml = Max. load · me = Max. efficiency · fa = Free air · cs = Customer specification · ce = Customer equipment  
Subject to change

## Data according to Commission Regulation (EU) 327/2011 (EN 17166)

		Actual	Req. 2015			
01 Overall efficiency $\eta_{es}$	%	55.1	29.3	09 Power consumption $P_e$	kW	0.2
02 Measurement category		A		09 Air flow $q_v$	m <sup>3</sup> /h	1590
03 Efficiency category		Static		09 Pressure increase $p_{fs}$	Pa	225
04 Efficiency grade N		65.8	40	10 Speed (rpm) $n$	min <sup>-1</sup>	2950
05 Variable speed drive		Yes		11 Specific ratio*		1.00

Data obtained at optimum efficiency level.

The ErP data is determined using a motor-impeller combination in a standardized measurement setup.

\* Specific ratio =  $1 + p_s / 100\,000\text{ Pa}$

LU-207262



# EC axial fan

with brushless DC motor

Fan housing with guide vanes, Automotive

## Technical description

<b>Weight</b>	2 kg
<b>Size</b>	300 mm
<b>Motor size</b>	84
<b>Blade material</b>	PA plastic
<b>Fan housing material</b>	PP plastic
<b>Number of blades</b>	7
<b>Airflow direction</b>	V
<b>Balancing grade according to DIN ISO 1940-1</b>	G 16
<b>Direction of rotation</b>	Clockwise, viewed toward rotor
<b>Degree of protection</b>	Motor IP24 KM, electronics IP6K9K (mating connector installed)
<b>Insulation class</b>	"B"
<b>Moisture (F) / Environmental (H) protection class</b>	H4
<b>Ambient temperature note</b>	Occasional start-up at temperatures between -40°C and -25°C is permitted. For continuous operation at ambient temperatures below -25°C (such as refrigeration applications), use must be made of a fan design with special low-temperature bearings.
<b>Max. permitted ambient temp. for motor (transport/storage)</b>	+85 °C
<b>Min. permitted ambient temp. for motor (transport/storage)</b>	-40 °C
<b>Installation position</b>	Any
<b>Mode</b>	S1
<b>Motor bearing</b>	Ball bearing; (sealed)
<b>Life expectancy</b>	40,000 h (typical)
<b>Technical features</b>	<ul style="list-style-type: none"> <li>- Locked-rotor detection</li> <li>- Error output (high-side switch)</li> <li>- Power limiter</li> <li>- Load dump (58 V)</li> <li>- Motor current limitation</li> <li>- Soft start</li> <li>- Control input 0-10 VDC / PWM</li> <li>- Temperature derating</li> <li>- Thermal overload protection for electronics</li> <li>- Reverse polarity protection</li> </ul>
<b>Electrical hookup</b>	Plug; Standby current less than 500 µA
<b>Approval</b>	EAC



# EC axial fan

with brushless DC motor

Fan housing with guide vanes, Automotive

## Product drawing

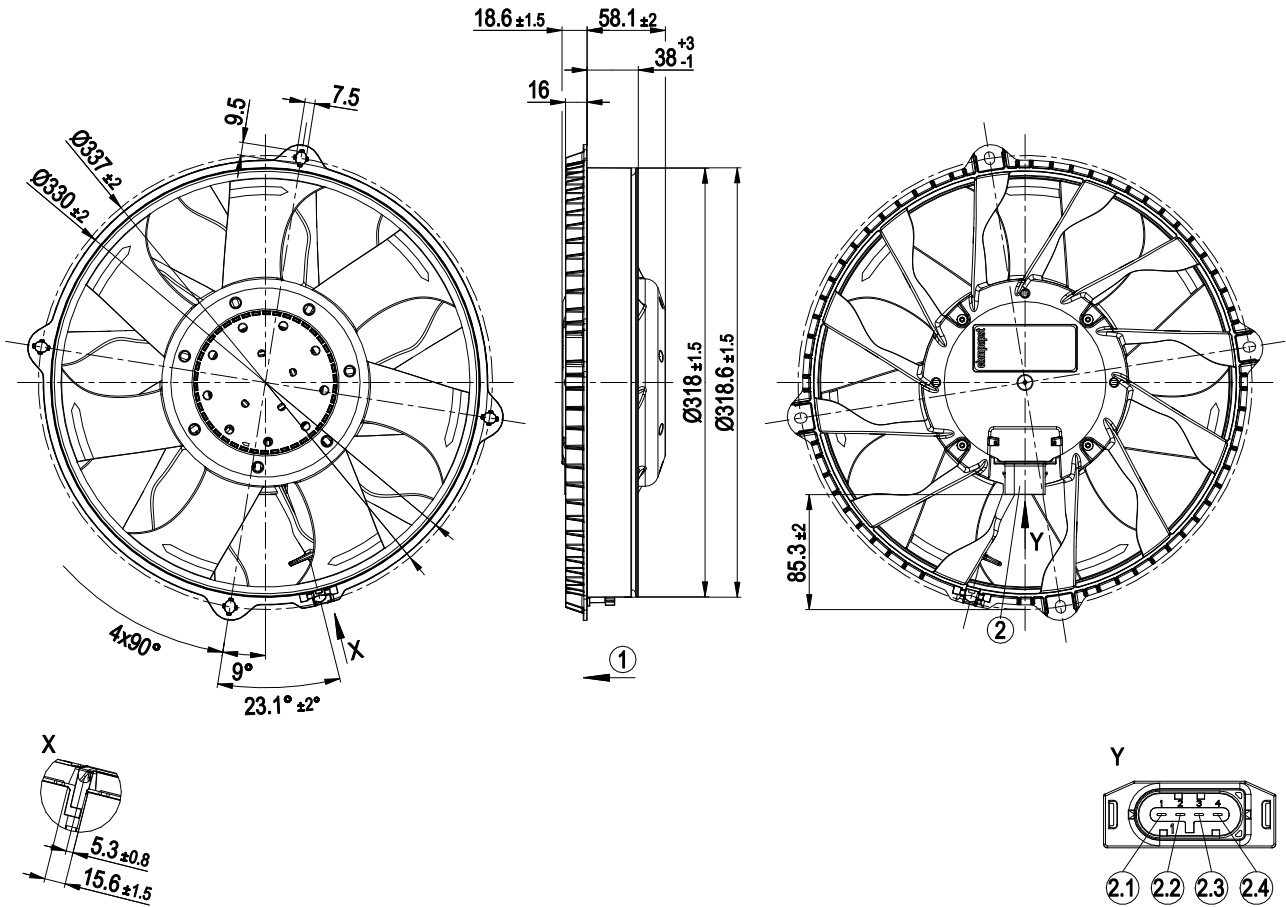

1	Airflow direction "V"
2	4-pole plug, pluggable with cable from accessories
2.1	Diagnostic output
2.2	PWM/LIN
2.3	+ UB
2.4	GND
Accessory part: Cable (460 mm) with mating connector, part no. 02040-4-1021 not included in scope of delivery 4-pole mating connector TE 1-1718628-1, 2x plug contact TE 1-968857-1, 2x plug contact TE 1-968855-1, 2x seal TE 828905-1, 2x seal TE 828904-1	



# EC axial fan

with brushless DC motor

Fan housing with guide vanes, Automotive

## Connection diagram

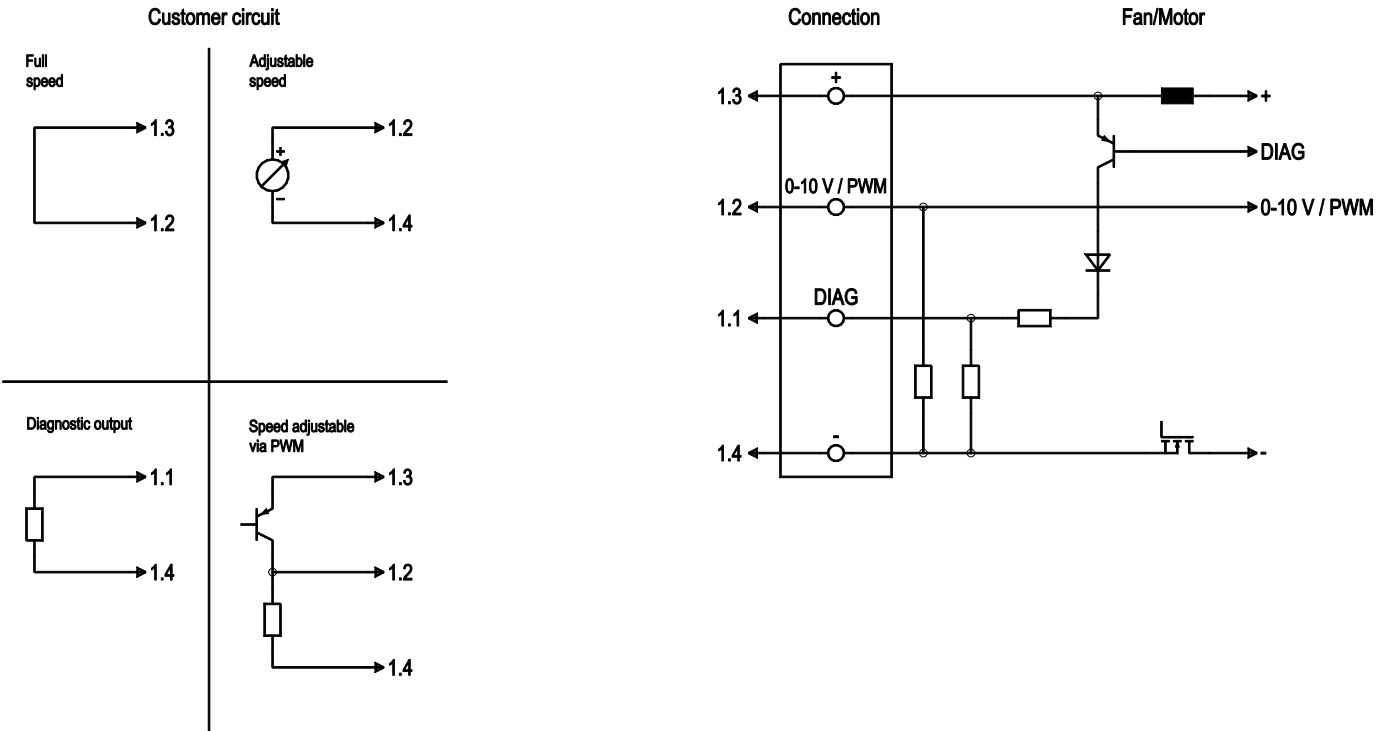

No.	Conn.	Designation	Function/assignment
	1.3	+	Power supply +
	1.4	-	Power supply -
	1.2	0-10 V / PWM	Control input: $R_i > 27\text{ k}\Omega$ 0-10 V: (typ. 0.5 V -> Standby; 1.5 V -> n = min.; 9.5 V -> n = max.) or PWM: (12 V - $U_b$ ; 1 kHz - 10 kHz; typ. < 1% -> standby; 10% -> n = min.; 95% -> n = max.)
	1.1	DIAG	Diagnostic output: Open Collector, $I_{source\ max} = 10\text{ mA}$ , $R_{source} = 2\text{ k}\Omega$ ; $R_{sink} = 100\text{ k}\Omega$ fan OK -> low; fan error -> high



# EC axial fan

with brushless DC motor

Fan housing with guide vanes, Automotive

## Curves: Air performance

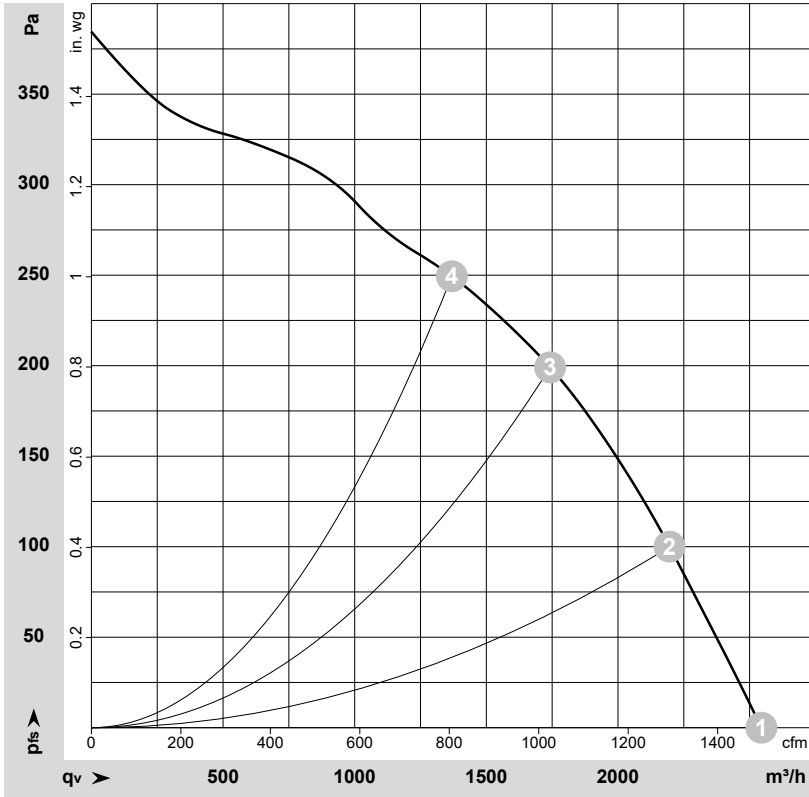

$\rho = 1.15 \text{ kg/m}^3 \pm 2 \%$

Measurement: LU-209001-1

Air performance measured according to ISO 5801 installation category A. For detailed information on the measurement setup, contact ebmpapst. Intake sound level: Sound power level according to ISO 13347 / sound pressure level measured at 1 m distance from fan axis. The values given are valid under the specified measuring conditions and may vary due to conditions of installation. For deviations from the standard configuration, the parameters have to be checked on the installed unit.

## Measured values

	U	n	P <sub>ed</sub>	I	LpA <sub>in</sub>	LwA <sub>in</sub>	q <sub>v</sub>	p <sub>fs</sub>	q <sub>v</sub>	p <sub>fs</sub>
	V	min <sup>-1</sup>	W	A	dB(A)	dB(A)	m <sup>3</sup> /h	Pa	cfm	in. wg
1	26	3000	177	6.81	76	82	2545	0	1500	0.00
2	26	2970	193	7.41	75	82	2195	100	1295	0.40
3	26	2950	202	7.75	76	83	1740	200	1025	0.80
4	26	2965	203	7.79	77	84	1370	250	805	1.00

U = Voltage · n = Speed (rpm) · P<sub>ed</sub> = Power consumption · I = Current draw · LpA<sub>in</sub> = Sound pressure level intake side · LwA<sub>in</sub> = Sound power level intake side · q<sub>v</sub> = Air flow  
p<sub>fs</sub> = Pressure increase

