



## 2.5 G Avalanche Photodiode OTDR

### Description

The A25-OTDR is an avalanche photodiode specifically designed for OTDR applications. This device was optimized to deliver low dark current and low spectral noise density. This makes the device ideal for OTDR applications. This device offers a direct drop in TO-Can package with customizable single mode fiber.

### Features

- Dark Current  $\sim 2$  nA
- Spectral Noise Density  $\sim 1 \frac{pA}{\sqrt{Hz}}$
- Terminal Capacitance 0.35 pF at VBR<sub>90%</sub>
- High Quantum efficiency
  - $\eta = 90\%$  at  $\lambda = 1310$  nm, M=1
  - $\eta = 77\%$  at  $\lambda = 1550$  nm, M=1
- 2.5 GHz Cutoff Frequency
- Ability to choose desired optical connector.
- Ability to choose desired fiber type.



### Applications

- Optical time-domain reflectometer (OTDR)

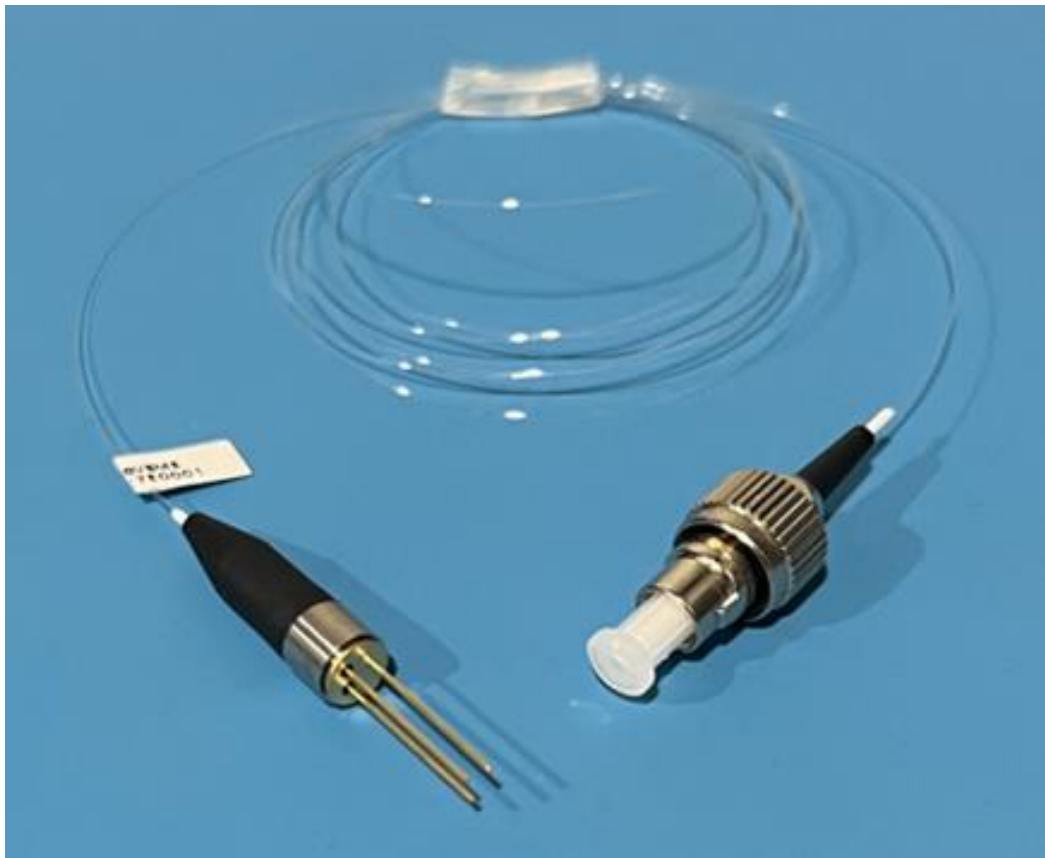

**Electro-Optical Characteristics ( $T_{op} 23 \pm 3^{\circ}C$ , unless otherwise specified)**

Parameter	Symbol	Min.	Typ.	Max	Unit	Notes
Reverse Breakdown Voltage	VBR	40	45	55	V	ID = 100
Temperature Coefficient reverse breakdown voltage	$\delta$		0.2		%/°C	
Dark Current	ID	1	2	25	nA	Taken at 90% VBR
Multiplied Dark Current	IDM		1	3	nA	M = 2 to 10
Terminal Capacitance	Ct		0.35		Pf	Taken at 90% VBR at f = 1 MHz
Cut-Off Frequency	fC		2.5		GHz	M = 10
Quantum Efficiency	$\eta$	76	90		%	$\lambda = 1310 \text{ nm}$ , M = 1
		65	77			$\lambda = 1550 \text{ nm}$ , M = 1
Responsivity	S	0.85	0.9		A/W	$\lambda = 1310 \text{ nm}$ , M = 1
		0.9	0.95			$\lambda = 1550 \text{ nm}$ , M = 1
Multiplication factor	M	30	40			$\lambda = 1310 \text{ nm}$ , IPO = 1.0 $\mu\text{w}$ , VR = V (at ID = 1 $\mu\text{A}$ )
Excess Noise Factor	X		0.7			$\lambda = 1310 \text{ nm}$ , IPO = 1.0 $\mu\text{w}$ , M = 10, f = 35 MHz
	F		5			$\lambda = 1310 \text{ nm}$ , IPO = 1.0 $\mu\text{w}$ , M = 10, f = 35 MHz
Optical Return Loss	ORL	30			dB	SMF
Spectral Noise Density	SN	0.2	0.5	1.5	$\frac{pA}{\sqrt{Hz}}$	Taken at M = 40, 50, and 60 with DC source

**Absolute Maximum Ratings**

Parameter	Symbol	Condition	Min.	Max.	Unit
Reverse Voltage	$V_r$			55	V
Forward Current	$I_f$			8	mA
Reverse Current	$I_R$			0.5	mA
Optical Input power	$P_{in}$			10	mW
Storage Temperature	$T_{stg}$		-25	90	°C
Storage Humidity	$H_{stg}$			85	% r.H.
Operating Temperature	$T_{op}$		-10	80	°C
Soldering Temperature	$T_{st}$	60 sec		200	°C
ESD Susceptibility		HBM	100		V

Operating at maximum ratings for a prolonged period will cause damage to the device.



## Pin Configuration

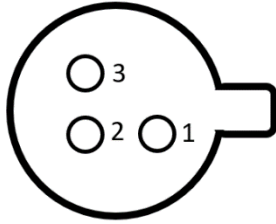

Fig 1A: Bottom View

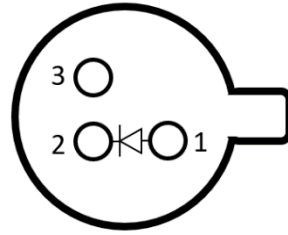

Fig 1B: Functional Diagram

Pin Number	Function
1	PD Anode (+)
2	PD Cathode (-)
3	Case Ground

Table 1: Device Pin out

## Device Dimensions

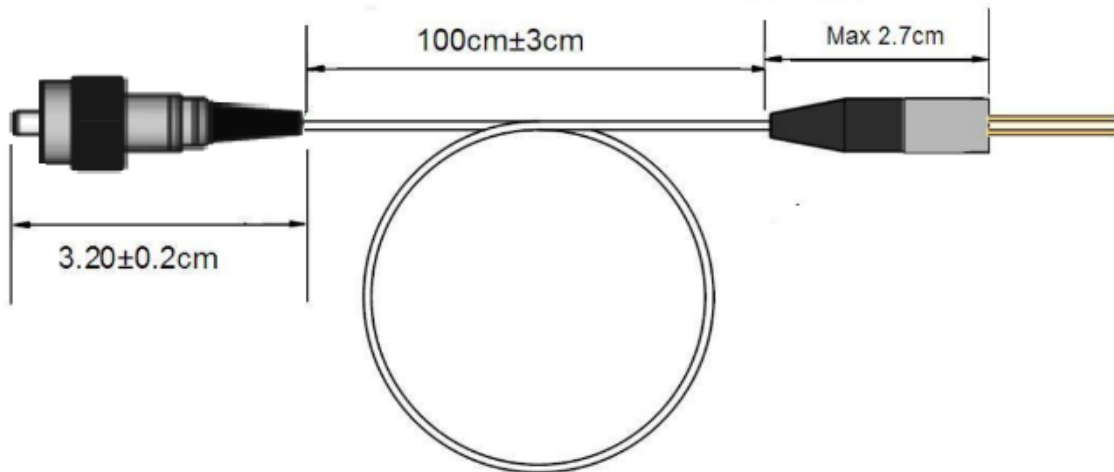
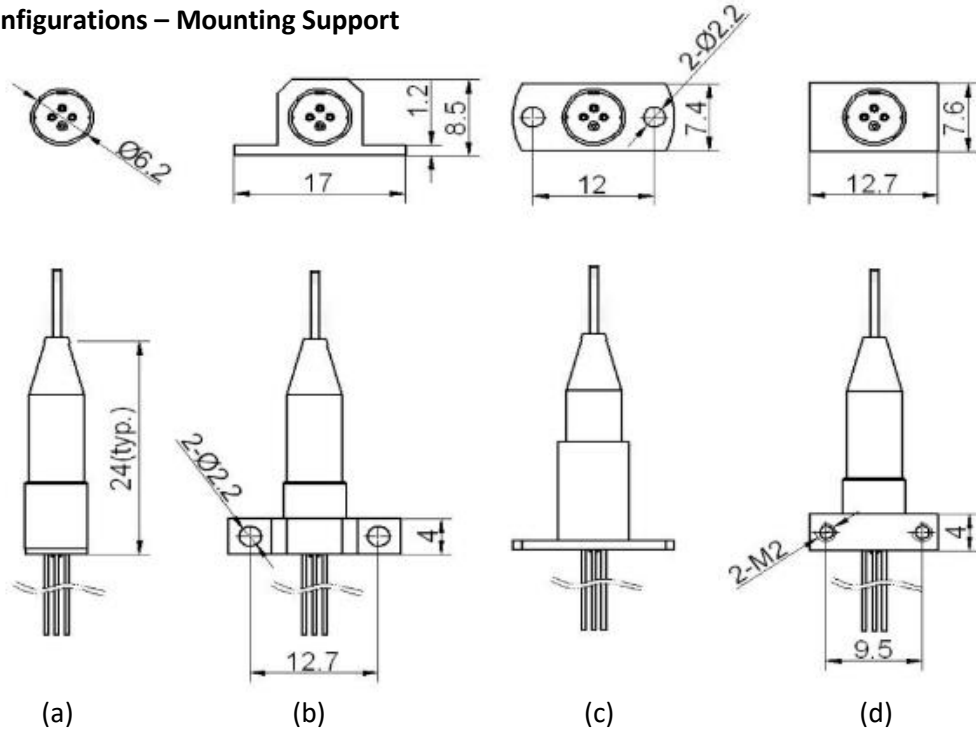

Fig 2: Device mechanical drawing. (All units in mm). Fiber and connector size differs based on build configuration.



### Build Configurations – Mounting Support



### Device Nomenclature

**A25-TO-X-XX**

**Product Line – 2.5G Avalanche Photodiode**

**Device body style – TO-CAN**

**Device Mounting Support;**

**Optical Connector**

- (a) No Mount
- (b) Horizontal Mount
- (c) Vertical Mount
- (d) Horizontal threaded

- (00) No Connector
- (FA) FC/APC
- (FP) FC/PC
- (CA) LC/APC
- (CP) LC/PC



### **Inquiry Information**

**Sales:** All inquiries regarding sales please contact [Sales@NuPhotonics.com](mailto:Sales@NuPhotonics.com)

**General:** If you are interested in a custom solution, general information, or engineering related information please contact [Inquiry@NuPhotonics.com](mailto:Inquiry@NuPhotonics.com)



# IMPORTANT NOTICES AND DISCLAIMERS

Warranty: NUPHOTONICS PROVIDES ALL OF THE INFORMATION ON TECHNICAL AND RELIABILITY DATA. THIS INCLUDES INFORMATION PRESENTED IN DATA SHEETS, DESIGN FILES, APPLICATIONS, AND OTHER RESOURCES "AS IS" AND WITH ALL FAULTS, AND DISCLAIMS ALL WARRANTIES, EXPRESS AND IMPLIED, INCLUDING WITHOUT LIMITATION ANY IMPLIED WARRANTIES OF MERCHANTABILITY, FITNESS FOR A PARTICULAR PURPOSE OR NON-INFRINGEMENT OF THIRD-PARTY INTELLECTUAL PROPERTY RIGHTS.

The information and resources are presented and intended for developers that are skilled and adequately qualified to work with this technology. You, the customer, are solely responsible for and accept full responsibility for selecting the appropriate NuPhotonics devices for your application. You accept the sole responsibility of designing, validating, and testing your application. You bear all responsibility for your application meeting standards, safety, security, and other regulatory requirements.

NuPhotonics retains the right to change these resources without notice. All rights are reserved for NuPhotonics. NuPhotonics grants you permission to use the information in these resources to design with NuPhotonics devices. Reproduction and display of these resources is prohibited. No Third-party licenses are offered. You will fully indemnify NuPhotonics against any claims, damages, costs, losses, and liabilities that arise from you using these resources.

NuPhotonics does not accept and objects to any terms you have proposed.

For terms and conditions for all NuPhotonics products please refer to [www.nuphotonics.com](http://www.nuphotonics.com) Legal section.

Definitions: Product State

Alpha Build: Devices in Alpha build are in internal engineering build and testing stages. Major changes may happen for production build.

Beta Build: Devices in Beta build are for external customer and engineering sample testing stages. Minor changes may happen for production build.

Production Build: Customer ready devices. Small appearance changes may occur between devices.

Obsolete: Currently not supported.