

NOTES: UNLESS OTHERWISE SPECIFIED

- 1. PERFORMANCE:
MAX CURRENT: 10 AMPS
- 2. CONNECTION TYPES: SOLDER OR CRIMP

LTR	DESCRIPTION	REVISIONS	
		DATE	APPROVED

∅0.31 [∅7.92]
MAX JAW OPENING

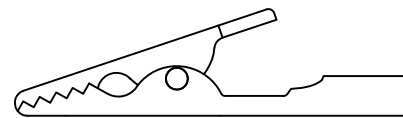
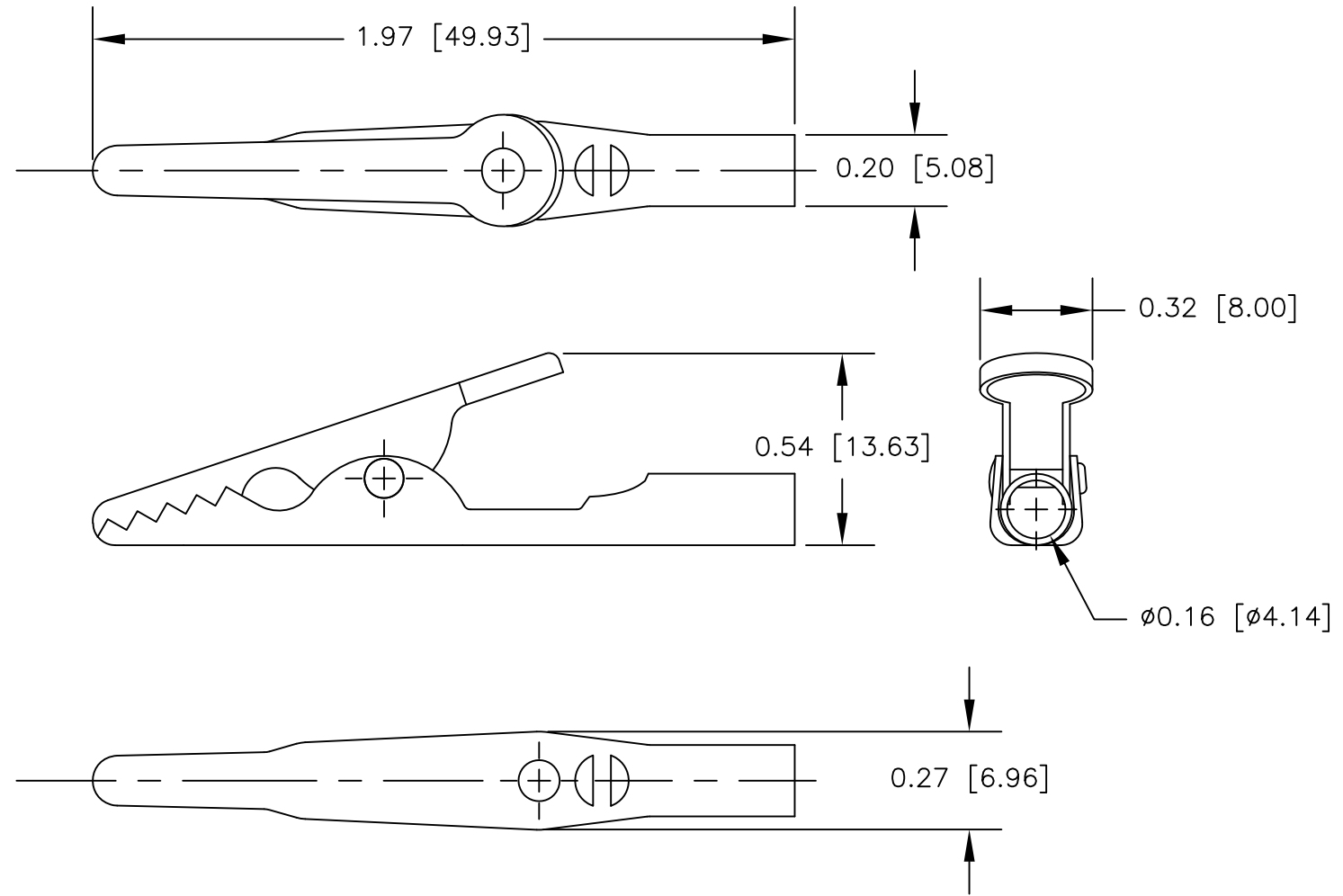
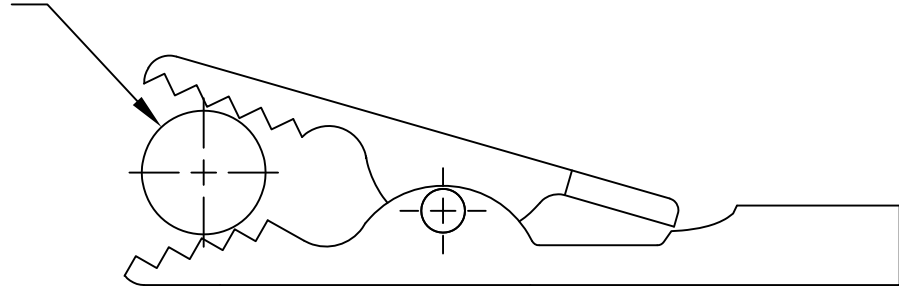

ACTUAL SIZE

		UNLESS OTHERWISE SPECIFIED DIMENSIONS ARE IN INCHES TOLERANCES ARE: FRACTIONS DECIMALS ANGLES ± .XX ± ± .XXX ±	CONTRACT NO.		E-Z-HOOK DIVISION OF TEKTEST INC. ARCADIA, CA 91006 U.S.A.	
			APPROVALS	DATE		
		MATERIAL STEEL	DRAWN	S.B.W. 10/92	DESCRIPTION STANDARD ALLIGATOR CLIP	
			APPROVED BY			
		FINISH NICKEL PLATED	SIZE	CODE IDENT NO.	DRAWING NO.	REV.
NEXT ASSY	USED ON			B	08505	9270
APPLICATION		DO NOT SCALE DRAWING	SCALE	4:1	SHEET 1 OF 1	