

# Magnetic Products

For Industrial, Commercial and Retail Applications

The world renowned  
**HERITAGE**  
range

**UTILITY**

**WORKSHOP**

**PRECISION**

**ULTRALIFT**

**ELECTRO**

 **ECLIPSE**  
**MAGNETICS**

# Eclipse Magnetics

Over 100 Years of Manufacturing Excellence

Eclipse Magnetics is at the forefront of development in magnetic materials and design. With over 100 years experience, we have a proven track record for supplying quality products and providing total customer support to some of the leading names in the industry.

Eclipse Tools North America Inc., is a wholly owned subsidiary of Spear & Jackson PLC, and is responsible for the sales, distribution, and customer service of the Eclipse Magnetics range throughout North America.

## You've used our products...

There's a very good chance that today you've used something that either contains or was manufactured with the aid of an Eclipse Magnetics product.

## Our range includes over 20,000

magnets and magnetic products which are used in most industries, including automotive, steel, food, environmental, communications, petrochemical, and engineering as well as in commercial, office, and retail premises. Almost all our products are available direct from stock.

## Worldwide reach

Our sales and service network provides technical advice and support all over the world.



## Contents



P1-2

The world famous Eclipse branded range of magnets and pot magnets. A variety of value adding products which encompass over 100 years of magnet heritage and quality.



P3-6

A range of high performance magnet materials and assemblies for a variety of applications, from basic clamping or holding to complex design engineering projects.



P7-10

Innovative magnetic products for workshop, factory or DIY applications, including welding clamps, pick-up equipment, tool holders and trays.



P11-13

Magnetic bases and chucks for quick, easy mounting and maintaining precision accuracy in measurement or machining applications.

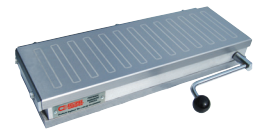

P14-15

Improve steel lifting efficiency and safety with our range of easy operation magnetic lifters.



P16

High quality Electromagnets for hold and release applications including access control and automation projects.

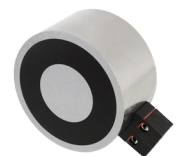

## Guide to Magnetic Materials

P17

We are proud of our magnet heritage which began in 1914. In fact our Heritage range is globally recognized as a symbol of high quality craftsmanship and guaranteed high performance. Over the years, we have set the benchmark for magnet quality and pioneered magnet designs which have become the industry norm worldwide.

## Alnico

- Alnico 5 magnet material (unless stated)
- Magnetically stable at high temp.
- 550°C/1022°F max. operating temp. (unless stated)
- Good corrosion resistance

### Alnico Cylindrical Bars

- Sold in pairs
- Typical Applications: Reed switches, hall effect sensors, coin operated machines, security instruments, electrical meters, circuit boards



Product Number	Diameter	Length	Pairs / Pack
<b>METRIC</b>			
	mm	mm	
E805	6	20	10
E806	8	25	5
E807	10	30	5
<b>IMPERIAL</b>			
	in	in	
E805	0.236	0.787	10
E806	0.314	0.984	5
E807	0.393	1.181	5

### Alnico Rectangular Bars

- Sold in pairs
- North pole indicated by notch
- Typical Applications: Components for reed switches, relays, hall effect sensors, oil filters, educational use, laboratory use



Product Number	Material	Length	Width	Height	Pairs / Pack
<b>METRIC</b>					
		mm	mm	mm	
E842	Alnico 2	50	15.0	10	2
E843	Alnico 2	75	15.0	10	2
E844	Alnico 5	20	10.0	5	5
E845	Alnico 5	40	12.5	5	5
E846	Alnico 5	60	15.0	5	5
<b>IMPERIAL</b>					
		in	in	in	
E842	Alnico 2	1.968	0.590	0.393	2
E843	Alnico 2	2.953	0.590	0.393	2
E844	Alnico 5	0.787	0.393	0.197	5
E845	Alnico 5	1.575	0.492	0.197	5
E846	Alnico 5	2.362	0.590	0.197	5

### Alnico Minor

- Typical Applications: Educational use, DIY use, attracting, holding or clamping steel parts



Product Number	Length	Width	Height	Pole Gap	Pull Force	Units / Pack
<b>METRIC</b>						
	mm	mm	mm	mm	kg	
E801	22.2	7.9	11.1	6.3	0.9	10
<b>IMPERIAL</b>						
	in	in	in	in	lbs	
E801	0.874	0.311	0.437	0.252	2.0	10

### Alnico Buttons

- Max temperature 220°C / 428°F
- Typical Applications: Paint plant jigs, damping applications, relay switches, temperature sensitive devices



Product Number	Diameter	Height	Slot Size (Min-Max)	Hole Size	Pull Force	Units / Pack
<b>METRIC</b>						
	mm	mm	mm	mm	kg	
E821	12.7	9.5	4.0-7.2	4.4	0.7	10
E822	19.1	12.7	5.6-8.7	4.8	1.9	10
E823	25.4	15.9	5.6-8.7	4.8	3.4	10
E824	31.8	25.4	8.0-12.7	7.1	4.8	2
E825	22.2	19.1	6.3-6.3	4.8	3.0	10
<b>IMPERIAL</b>						
	in	in	in	in	lbs	
E821	0.500	0.375	0.16-0.28	0.177	1.5	10
E822	0.750	0.500	0.22-0.34	0.188	4.2	10
E823	1.000	0.625	0.22-0.34	0.188	7.5	10
E824	1.250	1.000	0.31-0.50	0.279	10.6	2
E825	0.874	0.750	0.25-0.25	0.188	6.6	10

### Alnico Pockets

- E802 Alnico 5
- E803 Alnico 2
- Typical Applications: Educational use, DIY use, holding and clamping steel parts



Product Number	Length	Width	Height	Width Of Gap	Pull Force	Units / Pack
<b>METRIC</b>						
	mm	mm	mm	mm	kg	
E802	28.5	7.6	25.4	6.3	2.4	10
E803	33.3	15.9	35.0	7.9	4.0	5
<b>IMPERIAL</b>						
	in	in	in	in	lbs	
E802	1.122	0.299	1.000	0.248	5.3	10
E803	1.311	0.625	1.378	0.311	8.8	5

# Alnico Power Magnets

- Typical Applications: Retrieval, welding/soldering fixtures, ultrasonic testing, crack detection, general attracting, clamping and holding steel parts



Product Number	Length	Width	Height	Width Of Gap	Hole Size	Hole Centres	Pull Force	Units / Pack
<b>METRIC</b>								
	mm	mm	mm	mm	mm	mm	kg	
811	30	20	20	15	5	n/a	5	5
812	40	25	25	20	5	n/a	9	5
813	45	30	30	23	5	n/a	12	2
814	57	41	35	28	2 x 7.9	32	24	1
815	70	57	41	34	2 x 7.9	38	37	1
816	79	83	54	39	2 x 9.5	43	47	1
817	60	62	40	32	n/a	n/a	35	1
818	79	86	54	48	n/a	n/a	60	1
<b>IMPERIAL</b>								
	in	in	in	in	in	in	lbs	
811	1.181	0.787	0.787	0.590	0.197	n/a	10	5
812	1.575	0.984	0.984	0.787	0.197	n/a	20	5
813	1.771	1.181	1.181	0.906	0.197	n/a	26	2
814	2.283	1.594	1.377	1.094	2 x 0.311	1.260	52	1
815	2.756	2.251	1.625	1.342	2 x 0.311	1.496	82	1
816	3.125	3.250	2.125	1.515	2 x 0.374	1.693	103	1
817	2.374	2.440	1.575	1.250	n/a	n/a	77	1
818	3.125	3.374	2.125	1.874	n/a	n/a	132	1

# Alnico Shallow Pots

- Max operating temperature 450°C / 842°F
- Mild steel pot
- Typical Applications: For height restricted applications, gripping, lifting, positioning jigs, soldering fixtures, general securing and fixtures



Product Number	Diameter	Thickness	Hole Size	Screw Head Size	Pull Force	Units / Pack
<b>METRIC</b>						
	mm	mm	mm		kg	
826	19.1	7.5	3.7-6.7	M3 csk	3.0	10
827	28.6	8.7	4.8-8.6	M4 csk	5.0	10
828	38.1	10.4	4.8-8.6	M4 csk	13.0	5
<b>IMPERIAL</b>						
	in	in	in		lbs	
826	0.750	0.295	0.145-0.263	M3 csk	6.6	10
827	1.125	0.344	0.189-0.339	M4 csk	11.0	10
828	1.500	0.407	0.189-0.339	M4 csk	28.6	5

# Alnico Deep Pots

- Max operating temperature 220°C / 425°F
- Mild steel pot, aluminum spacer
- Typical Applications: Gripping, lifting, positioning jigs, soldering fixtures, general securing and fixtures



Product Number	Diameter	Height	Thread Size	Pull Force	Units / Pack	Product Number	Diameter	Height	Thread Size	Pull Force	Units / Pack
<b>METRIC</b>						<b>IMPERIAL</b>					
	mm	mm		kg			in	in		lbs	
829	9.5	15	M3	1.0	10	829	0.375	0.594	M3	2.2	10
830	12.7	16	M4	2.0	10	830	0.500	0.625	M4	4.4	10
831NF	17.5	16	10 UNF	2.7	10	831NF	0.689	0.629	10 UNF	5.8	10
832NF	20.5	19	10 UNF	4.0	5	832NF	0.807	0.748	10 UNF	8.8	5
833NF	27.0	25	10 UNF	6.1	5	833NF	1.062	1.000	10 UNF	13.4	5
834NF	35.0	30	10 UNF	14.8	2	834NF	1.377	1.181	10 UNF	32.5	2

# Ceramic

- High resistance to demagnetization

# Ceramic Channels

- Max operating temperature 120°C / 248°F
- Mild steel body



Product Number	Length	Width	Height	Plain Fixing Holes	Hole Centres	Pull Force	Units / Pack
<b>METRIC</b>							
	mm	mm	mm	mm	mm	kg	
E898/2	130	30	13	4.2	90	14	5
E899	190	43	13	4.2	110	48	2
<b>IMPERIAL</b>							
	in	in	in	in	in	lbs	
E898/2	5.12	1.81	0.512	0.165	3.54	31	5
E899	7.48	1.69	0.512	0.165	4.33	106	2

# Ceramic Shallow Pots With Hook

- Max operating temperature 120°C/248°F
- Mild steel pot
- Removable hook
- Typical Applications: For height restricted applications, light lifting, holding, securing and clamping



With M6 tapped holes

Product Number	Diameter	Thickness	Thread	Pull Force	Units / Pack	Product Number	Diameter	Thickness	Thread	Pull Force	Units / Pack		
<b>METRIC</b>						<b>IMPERIAL</b>							
	mm	mm		kg			in	in		lbs			
E890	46	10.7	M6	6	5	E890	1.811	0.421	M6	13.2	5		
E891	56	10.7	M6	16	5	E891	2.205	0.421	M6	35.2	5		
E892	66	10.7	M6	25	5	E892	2.598	0.421	M6	55.0	5		
<b>Product Number</b>													
<b>Diameter</b>													
<b>Height</b>													
<b>Fixing Stud Centres PCD M6</b>													
<b>Central Fixing Point</b>													
<b>Pull Force</b>													
<b>Units / Pack</b>													
<b>METRIC</b>						<b>IMPERIAL</b>							
	mm	mm					in	in		lbs			
E895	66	10.7	46mm - 3 holes	M6	25	1	E895	2.598	0.421	1.811in - 3 holes	M6	55	1
E896	76	12.5	46mm - 3 holes	M6	33	1	E896	2.992	0.492	1.811in - 3 holes	M6	73	1
E897	100	15.5	70mm - 3 holes	M6	55	1	E897	3.937	0.590	2.756in - 3 holes	M6	121	1



Our Utility range includes a variety of magnet materials and assemblies which are ideal for design engineering and practical projects, from basic clamping and holding to complex power generation or sensor applications.

# Neodymium

- Also known as Rare Earth
- Strongest magnet material available
- N35 grade (Nickel plated)
- 80°C/176°F max. operating temp. (unless stated)
- Custom designs available

## Neodymium Discs

- Max operating temperature 120°C/248°F
- Ideal where compact size and maximum strength are required
- Ideal for retail, display or industrial holding or mounting applications



Product Number	Diameter	Thickness	Pull Force	Units / Pack	Product Number	Diameter	Thickness	Pull Force	Units / Pack
<b>METRIC</b>					<b>IMPERIAL</b>				
	mm	mm	kg			in	in	lbs	
N100	3.0	1.5	0.3	10	N100	0.12	0.06	0.7	10
N101	4.7	1.5	0.4	10	N101	0.19	0.06	0.8	10
N104	5.6	12.7	1.9	5	N104	0.22	0.50	4.1	5
N105	6.4	2.5	0.5	10	N105	0.25	0.10	1.2	10
N106	6.4	3.2	0.6	10	N106	0.25	0.13	1.4	10
N108	6.4	5.1	1.5	10	N108	0.25	0.20	3.3	10
N109	6.4	6.4	1.6	10	N109	0.25	0.25	3.5	10
N110	6.4	12.7	1.9	5	N110	0.25	0.50	4.3	5
N112	9.5	1.5	0.8	10	N112	0.38	0.06	1.8	10
N114	9.5	3.2	1.6	10	N114	0.38	0.13	3.6	10
N115	9.5	4.7	1.8	10	N115	0.38	0.19	4.0	10
N117	9.5	6.4	2.1	10	N117	0.38	0.25	4.7	10
N119	9.5	12.7	3.3	5	N119	0.38	0.50	7.2	5
N120	12.7	1.5	1.4	10	N120	0.50	0.06	3.0	10
N121	12.7	3.2	2.1	10	N121	0.50	0.13	4.6	10
N124	12.7	6.4	3.2	10	N124	0.50	0.25	7.0	10
N125	12.7	9.5	6.5	5	N125	0.50	0.38	14.3	5
N126	12.7	12.7	8.6	5	N126	0.50	0.50	19.0	5
N127	19.1	9.5	10.0	5	N127	0.75	0.38	22.0	5

## Neodymium Pots

- Ideal for retail, display or industrial holding or mounting applications
- Style A: Nickel Plated Pot
- Style B: Shallow Pot With Bolt
- Style C: Shallow Pot With Loop



Style	Product Number	Diameter	Thickness	Pull Figure	Style	Product Number	Diameter	Thickness	Pull Figure
	<b>METRIC</b>					<b>IMPERIAL</b>			
		mm	mm	kg			in	in	lbs
A	E684	51.6	4.6	67	A	E684	2.03	0.18	148
A	E685	66.5	9.4	91	A	E685	2.62	0.37	200
B	E686	51.6	4.6	43	B	E686	2.03	0.18	95
B	E687	51.6	4.6	67	B	E687	2.03	0.18	148
B	E688	66.5	9.4	91	B	E688	2.62	0.37	200
C	E689	51.6	20.6	43	C	E689	2.03	0.81	95
C	E690	51.6	20.6	67	C	E690	2.03	0.81	148
C	E691	66.5	25.4	91	C	E691	2.62	1.00	200

## Neodymium Shallow Pots With Threaded Hole

- Zinc plated body
- With female threaded hole for component mounting



Product Number	Diameter	Thickness	Total Height	Thread Size	Ferrule Outer Dia.	Pull Force	Units / Pack
<b>METRIC</b>							
	mm	mm	mm		mm	kg	
E770NEO	6	4.5	11.5	M3	6	0.5	20
E771NEO	8	4.5	11.5	M3	6	1.3	20
E772NEO	10	4.5	11.5	M3	6	2.5	20
E773NEO	13	4.5	11.5	M3	6	6.0	20
E774NEO	16	4.5	11.5	M4	8	9.5	20
E775NEO	20	6.0	13.0	M4	8	14.0	10
E776NEO	25	7.0	14.0	M4	8	20.0	10
E777NEO	32	7.0	15.5	M5	10	35.0	5
<b>IMPERIAL</b>							
	in	in	in		in	lbs	
E770NEO	0.236	0.177	0.450	M3	0.236	1.1	20
E771NEO	0.315	0.177	0.450	M3	0.236	2.9	20
E772NEO	0.394	0.177	0.450	M3	0.236	5.5	20
E773NEO	0.512	0.177	0.450	M3	0.236	13.2	20
E774NEO	0.630	0.177	0.450	M4	0.315	20.9	20
E775NEO	0.787	0.236	0.510	M4	0.315	30.8	10
E776NEO	0.984	0.275	0.550	M4	0.315	44.0	10
E777NEO	1.260	0.275	0.610	M5	0.394	77.0	5

## Neodymium Shallow Pots With Countersunk Hole

- Zinc plated body
- With countersunk hole for screw fixings



Product Number	Diameter	Thickness	Hole Size	Screw Head	Pull Force	Units / Pack
METRIC					kg	
E1000/NEO	16	4.5	3.5	M3	7.5	20
E1001/NEO	20	6.0	4.5	M4	10.5	10
E1002/NEO	25	7.0	4.5	M4	16.0	10
E1003/NEO	32	7.0	5.5	M5	31.0	10
E1004/NEO	40	8.0	5.5	M5	50.0	5
E1005/NEO	48	11.5	8.5	M8	87.0	1
IMPERIAL					lbs	
E1000/NEO	0.60	0.18	0.14	M3	16.5	20
E1001/NEO	0.80	0.25	0.18	M4	23.1	10
E1002/NEO	1.00	0.30	0.18	M4	35.3	10
E1003/NEO	1.25	0.30	0.22	M5	68.3	10
E1004/NEO	1.60	0.30	0.22	M5	110.2	5
E1005/NEO	1.90	0.45	0.33	M8	191.8	1

## Neodymium Hook Magnet

- Ideal for use in office, basement, garage, or home organization applications



Product Number	Diameter	Thickness	Thread Length	Thread Size	Pull Force	Units / Pack
METRIC					kg	
E2226	36.1	6.35	6.35	No. 6-32 UNC	18.1	1
IMPERIAL					lbs	
E2226	1.42	0.25	0.25	No. 6-32 UNC	40.0	1

## Neodymium Pot With Swivel Hook

- Ideal for use in office, basement, garage, or home organization applications



Product Number	Diameter	Thickness	Pull Force	Units / Pack
METRIC			kg	
E2227	38.1	12.7	29.5	1
IMPERIAL			lbs	
E2227	1.50	0.50	65.0	1

## Neodymium Bi-Pole Deep Pots With Threaded Hole

- Aluminum pot with mild steel pole pieces



Product Number	Diameter	Height	Thread Size	Pull Force	Units / Pack	Product Number	Diameter	Height	Thread Size	Pull Force	Units / Pack
METRIC						IMPERIAL					
NH025	12.7	12	M5	2.5	10	NH025	0.500	0.472	M5	5.5	10
NH065	16.0	16	M6	8.0	10	NH065	0.630	0.630	M6	17.6	10
NH130	22.2	20	M6	16.0	5	NH130	0.874	0.787	M6	35.3	5
NH240	25.4	25	M6	25.0	5	NH240	1.000	0.984	M6	55.1	5

# Alnico

## Alnico Pots

- Max operating temperature 220°C / 425°F
- Mild steel pot, aluminium spacer
- Typical Applications: Gripping, lifting, positioning jigs, soldering fixtures, general securing and fixtures



Product Number	Diameter	Length	Thread Size	Pull Force	Product Number	Diameter	Length	Thread Size	Pull Force
METRIC					IMPERIAL				
M19169NK	6.35	12.70	No. 6 UNC	0.09	M19169NK	0.250	0.500	No. 6 UNC	0.2
M19170NK	6.35	19.05	No. 6 UNC	0.14	M19170NK	0.250	0.750	No. 6 UNC	0.3
M19171NK	6.35	25.40	No. 6 UNC	0.18	M19171NK	0.250	1.000	No. 6 UNC	0.4
M19172NK	9.53	12.70	No. 6 UNC	0.64	M19172NK	0.375	0.500	No. 6 UNC	1.4
M19173NK	9.53	19.05	No. 6 UNC	0.68	M19173NK	0.375	0.750	No. 6 UNC	1.5
M19174NK	12.70	25.40	No. 6 UNC	0.77	M19174NK	0.375	1.000	No. 6 UNC	1.7
M19175NK	12.70	12.70	No. 6 UNC	1.13	M19175NK	0.500	0.500	No. 6 UNC	2.5
M19176NK	12.70	19.05	No. 6 UNC	1.36	M19176NK	0.500	0.750	No. 6 UNC	3.0
M19177NK	12.70	25.40	No. 6 UNC	1.36	M19177NK	0.500	1.000	No. 6 UNC	3.0
M19178NK	15.88	12.70	No. 10 UNC	1.04	M19178NK	0.625	0.500	No. 10 UNC	2.3
M19179NK	15.88	19.05	No. 10 UNC	1.81	M19179NK	0.625	0.750	No. 10 UNC	4.0
M19180NK	15.88	25.40	No. 10 UNC	1.81	M19180NK	0.625	1.000	No. 10 UNC	4.0
M19181NK	19.05	12.70	No. 10 UNC	2.27	M19181NK	0.750	0.500	No. 10 UNC	5.0
M19182NK	19.05	19.05	No. 10 UNC	4.08	M19182NK	0.750	0.750	No. 10 UNC	9.0
M19183NK	19.05	25.40	No. 10 UNC	4.08	M19183NK	0.750	1.000	No. 10 UNC	9.0
M19184NK	25.40	12.70	1/4" UNC	3.18	M19184NK	1.000	0.500	1/4" UNC	7.0
M19185NK	25.40	19.05	1/4" UNC	6.35	M19185NK	1.000	0.750	1/4" UNC	14.0
M19186NK	25.40	25.40	1/4" UNC	7.26	M19186NK	1.000	1.000	1/4" UNC	16.0
M19187NK	31.75	12.70	1/4" UNC	2.72	M19187NK	1.250	0.500	1/4" UNC	6.0
M19188NK	31.75	19.05	1/4" UNC	6.80	M19188NK	1.250	0.750	1/4" UNC	15.0
M19189NK	31.75	25.40	1/4" UNC	9.98	M19189NK	1.250	1.000	1/4" UNC	22.0
M19190NK	31.75	31.75	1/4" UNC	11.34	M19190NK	1.250	1.250	1/4" UNC	25.0

# Ceramic

- High resistance to demagnetization
- 80°C/176°F max. operating temp. (unless stated)

## Ceramic Low Profile Channels

- Steel channels with ceramic magnets
- 9/32" (7mm) mounting holes



Product Number	Length	Width	Height	Pull Force	Product Number	Length	Width	Height	Pull Force
METRIC					IMPERIAL				
	mm	mm	mm	kg		in	in	in	lbs
E660	139.7	34.9	9.5	12	E660	5.5	1.4	0.4	28
E662	139.7	34.9	14.3	22	E662	5.5	1.4	0.6	49
E663	304.8	38.1	8.7	6	E663	12.0	1.5	0.3	15
E664	304.8	38.1	15.9	13	E664	12.0	1.5	0.6	30
E665	304.8	50.8	15.9	20	E665	12.0	2.0	0.6	45
E666	304.8	50.8	15.9	27	E666	12.0	2.0	0.6	60

## Ceramic Pots

- Ideal for retail, display or industrial holding or mounting applications
- Style A: Nickel Plated Pot
- Style B: Shallow Pot With Bolt
- Style C: Shallow Pot With Loop



Style	Product Number	Diameter	Thickness	Pull Force	Style	Product Number	Diameter	Thickness	Pull Force
METRIC					IMPERIAL				
		mm	mm	kg			in	in	lbs
A	E680	31.8	4.8	2	A	E680	1.25	0.19	4
A	E681	51.6	7.9	17	A	E681	2.03	0.31	38
A	E682	66.8	9.7	37	A	E682	2.63	0.38	82
A	E683	82.6	11.2	43	A	E683	3.25	0.44	95
A	E2135	124.0	13.0	90	A	E2135	4.90	0.50	200
B	E692	30.6	30.2	2	B	E692	1.20	1.19	4
B	E693	51.6	46.0	17	B	E693	2.03	1.81	38
B	E694	57.2	30.2	5	B	E694	2.25	1.19	10
B	E695	66.7	50.8	37	B	E695	2.63	1.94	82
B	E696	96.8	47.6	43	B	E696	3.81	1.88	95
C	E697	66.5	50.8	37	C	E697	2.62	1.94	82
C	E698	82.6	30.2	43	C	E698	3.25	1.19	96

## Ceramic Shallow Pots With Countersunk Hole

- For screw fixing

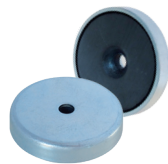

Product Number	Diameter	Thickness	Hole Size	Screw Head	Pull Force	Units / Pack
METRIC						
	mm	mm	mm		kg	
E876	25	7	5.5	M5	4.5	10
E877	32	7	5.5	M5	10.0	10
E878	40	8	5.5	M5	20.0	5
IMPERIAL						
	in	in	in		lbs	
E876	0.984	0.276	0.217	M5	9.9	10
E877	1.260	0.276	0.217	M5	22.0	10
E878	1.575	0.315	0.217	M5	44.1	5

## Ceramic Pots With Hooks

- Max. operating temperature 120°C/248°F
- Mild steel pot painted white
- Ideal for retail or general display applications
- For hanging graphics, utensils, tools etc



Product Number	Diameter	Height	Thickness	Thread	Pull Force	Units / Pack
METRIC						
	mm	mm	mm		kg	
E879-RB	25	8	34	M4	4.0	1
E880-RB	32	8	34	M4	8.0	1
E881-RB	36	8	34	M4	10.0	1
IMPERIAL						
	in	in	in		lbs	
E879-RB	0.985	0.315	1.339	M4	8.8	1
E880-RB	1.260	0.315	1.339	M4	17.6	1
E881-RB	1.417	0.315	1.339	M4	22.0	1

## Ceramic Shallow Pots With Threaded Hole

- Max. operating temperature 120°C/248°F
- Mild steel pot
- Zinc plated
- Female thread
- Ideal for mounting components with screw or bolt



Product Number	Diameter	Thickness	Overall Height	Thread	Pull Force	Units / Pack
<b>METRIC</b>						
	mm	mm	mm		kg	
E860	10	5	11.0	M3	0.4	20
E861	13	5	11.5	M3	1.0	20
E862	16	5	11.5	M3	1.8	20
E863	20	6	13.0	M3	3.0	10
E864	25	7	15.0	M4	4.0	10
E865	32	7	15.0	M4	8.0	5
E866	36	7	16.0	M4	10.0	5
E867	40	8	18.0	M5	12.5	5
E868	47	9	17.0	M4	18.0	1
E869	50	10	22.0	M6	22.0	1
E870	57	11	18.5	M4	28.0	1
E871	63	14	30.0	M8	35.0	1
E872	80	18	34.0	M10	60.0	1
E873	90	20	40.0	M10	70.0	1
E874	100	22	42.0	M12	90.0	1
E875	125	26	50.0	M14	130.0	1
<b>IMPERIAL</b>						
	in	in	in		lbs	
E860	0.394	0.177	0.433	M3	0.9	20
E861	0.512	0.177	0.453	M3	2.2	20
E862	0.629	0.177	0.453	M3	3.9	20
E863	0.787	0.236	0.512	M3	6.6	10
E864	0.984	0.276	0.591	M4	8.8	10
E865	1.260	0.276	0.591	M4	17.6	5
E866	1.417	0.276	0.630	M4	22.0	5
E867	1.575	0.315	0.709	M5	27.5	5
E868	1.850	0.354	0.669	M4	39.6	1
E869	1.969	0.394	0.866	M6	48.4	1
E870	2.240	0.433	0.728	M4	61.6	1
E871	2.480	0.551	1.181	M8	77.0	1
E872	3.150	0.708	1.339	M10	132.0	1
E873	3.543	0.787	1.575	M10	154.0	1
E874	3.937	0.866	1.654	M12	198.0	1
E875	4.921	1.024	1.969	M14	286.0	1

## Round Base Magnet

- Style A: Shallow Pot
- Style B: Nickel Plated Pot
- Style C: Shallow Pot With Thread



Style	Product Number	Diameter	Thickness	Hole Size	Pull Force	Style	Product Number	Diameter	Thickness	Hole Size	Pull Force	
		METRIC	mm	mm	mm	kg		IMPERIAL	in	in	in	lbs
A	E2100	30.7	4.34	3.18	1.8	A	E2100	1.21	0.171	0.125	4	
A	E2110	36.1	7.19	4.77	7.3	A	E2110	1.42	0.283	0.188	16	
A	E2116	35.6	7.19	5.08	7.3	A	E2116	1.40	0.283	0.190	16	
B	E2140	81.3	12.70	-	43.1	B	E2140	3.20	0.500	-	95	
C	E2115	43.2	7.62	10 UNC	5.4	C	E2115	1.70	0.300	10 UNC	12	

## Samarium Cobalt

### Samarium Cobalt Deep Pots

- Shell material Brass
- Max. operating temperature 200°C/392°F
- Ideal for use in jigs, assembly fixtures and positioning



Product Number	Diameter	Height	Pull Force	Product Number	Diameter	Height	Pull Force
<b>METRIC</b>				<b>IMPERIAL</b>			
	mm	mm	kg		in	in	lbs
E750	6	20	0.8	E750	0.236	0.787	1.8
E751	8	20	2.2	E751	0.315	0.787	4.8
E752	10	20	4.0	E752	0.394	0.787	8.8
E753	13	20	6.0	E753	0.512	0.787	13.2
E754	16	20	12.5	E754	0.630	0.787	27.5
E755	20	25	23.0	E755	0.787	0.984	50.6
E756	25	35	40.0	E756	0.984	1.378	88.0
E757	32	40	60.0	E757	1.260	1.575	132.0

### Samarium Cobalt Shallow Pots

- Shell material Steel
- Max. operating temperature 200°C/392°F
- Ideal for use in jigs, assembly fixtures and assemblies



Product Number	Diameter	Height	Pull Force	Product Number	Diameter	Height	Pull Force
<b>METRIC</b>				<b>IMPERIAL</b>			
	mm	mm	kg		in	in	lbs
E760	6	4.5	0.5	E760	0.236	0.177	1.1
E761	8	4.5	1.1	E761	0.315	0.177	2.4
E762	10	4.5	2.0	E762	0.394	0.177	4.4
E763	13	4.5	4.0	E763	0.512	0.177	8.8
E764	16	4.5	6.0	E764	0.630	0.177	13.2
E765	20	6.0	9.0	E765	0.787	0.236	19.8
E766	25	7.0	15.0	E766	0.984	0.276	33.0
E767	32	7.0	22.0	E767	1.260	0.276	48.4



Our Workshop range includes a variety of innovative magnetic devices for solving challenging problems in workshops or factories. It includes simple magnetic tools and magnetic welding clamps.

## Recovery Tool

- Constructed from a ferrite magnet sandwiched between two steel plates
- Designed for recovery or retrieval, such as recovering objects from coolant tanks or vats



Product Number	Width	Height	Thickness	Pull Force
METRIC	mm	mm	mm	kg
E936	80	101.5	36	50
IMPERIAL	in	in	in	lbs
E936	3.1	4.0	1.4	110

## Heavy Duty Magnetic Tool Rack

- Ideal for use in the home, garage or workshop
- Modular design allows multiple units to be connected
- Non-magnetic tools can be placed between the rack and the wall



Product Number	Overall Length	Body Width	Body Depth
METRIC	mm	mm	mm
MTR250	345	24.5	14
IMPERIAL	in	in	in
MTR250	13.6	0.96	0.6

## Magnetic Trays

- Magnet in base attaches the tray firmly to ferrous surfaces and holds ferrous items in the tray
- Magnet base is rubber coated to safeguard surfaces



Product Number	Dimensions	Product Number	Dimensions
METRIC	mm	IMPERIAL	in
E630	360.7 x 130.0	E630	14.2 x 6.3
E631	292.1 x 271.8	E631	11.5 x 10.7
E632	241.3 x 142.2	E632	9.5 x 5.6
E633	149.9 D	E633	5.9 D
E634	109.2 D	E634	4.3 D

## Telescopic Pick-up Tool

- Powerful neodymium iron boron magnets are used to ensure maximum pull from a small magnetic area
- Ideal for retrieving ferrous objects that are out of reach



Product Number	Length	Pull Force
METRIC	mm	kg
EM967-R	147-660	1
IMPERIAL	in	lbs
EM967-R	5.8-26.0	2.1

## Magnetic Sweeper

- Adjustable telescopic handles
- Quickly and easily clear workshop and factory floors, sports pitches and car parks of spilt items or potentially dangerous metal debris like pins, nails and metal fragments
- Handle mounted quick release mechanism



Product Number	Head Width	Height Including Handle	Pull Force
METRIC	mm	mm	kg
MSW385	385	1050	2
IMPERIAL	in	in	lbs
MSW385	16.0	41.3	4.4

## Swarf Wand

- Separate small parts after rumblings
- Quick release handle
- Lightweight, non-rusting shaft



Product Number	Length	Collection Capacity
METRIC	mm	kg
MW400	400	6.35
IMPERIAL	in	lbs
MW400	15.8	14.0

## Sheet Floaters

- Sheet separators use magnetic repulsion to separate sheets in a stack so they can be removed more easily
- Sold in pairs

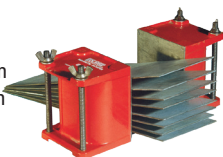

Product Number	Width	Height	Depth	Mounting Hole Size
METRIC	mm	mm	mm	
E913	73	76	65	M8
E914	92	102	76	M8
E915	113	152	89	M10
IMPERIAL	in	in	in	
E913	2.87	2.99	2.55	M8
E914	3.62	4.02	2.99	M8
E915	4.45	5.98	3.50	M10

## Magnetic Tape

- Material: Stronium ferrite in thermo-plastic binder.
- Max operating temperature: 80°C/176°F
- Magnetic on 1 face only
- Can be cut with scissors

All supplied with standard acrylic adhesive.



Product Number	Width	Thickness	Length	Pull Force	Units / Pack
METRIC					
EM884-R	13.0	0.50	1	28	1
FM660	7.5	0.75	10	44	1
FM661	12.5	0.75	10	44	1
FM662	20.0	0.75	10	44	1
IMPERIAL					
EM884-R	0.511	0.02	3.3	1.0	1
FM660	0.295	0.03	32.8	1.6	1
FM661	0.492	0.03	32.8	1.6	1
FM662	0.787	0.03	32.8	1.6	1

## Magnetic Extrusion

- Material: Stronium ferrite in thermo-plastic binder
- Max operating temperature: 80°C/176°F
- Magnetic on 1 face only
- Forms a strong bond when paired with itself



Product Number	Width	Thickness	Length	Pull Force	Units / Pack
METRIC					
EM880-R	9.5	3.6	2	65	1
FM670	9.5	3.6	10	65	1
FM671	11	4.6	10	65	1
FM672	15	6.4	10	65	1
IMPERIAL					
EM880-R	0.375	0.141	6.6	2.35	1
FM670	0.375	0.141	32.8	2.35	1
FM671	0.433	0.181	32.8	2.35	1
FM672	0.590	0.251	32.8	2.35	1

## Round Holding Magnet

- Ceramic magnet with handle



Product Number	Diameter	Thickness	Pull Force	Product Number	Diameter	Thickness	Pull Force	
METRIC		mm	mm	kg	IMPERIAL			in
E2600	36.2	7.2	7.3	E2600	1.425	0.283	16	
E2601	50.8	8.0	11.3	E2601	2.000	0.315	25	
E2602	66.7	9.5	29.5	E2602	2.625	0.374	65	
E2603	81.4	10.8	43.1	E2603	3.203	0.425	95	

## Table-Top Demagnetiser

- Lightweight unit for the removal of residual magnetism from components after workholding



Product Number	Voltage	Width	Height	Depth
METRIC				
DB956CAN	110	150	117	87
IMPERIAL				
DB956CAN	110	5.90	4.61	3.43

## 'V' Blocks

- Material Alnico 5
- Ideal for holding cylindrical and complex workpieces for marking, sparking erosion, grinding, and measurement operations
- Can be used on base, side, or end
- Top 'V' maximum diameter 65mm/2.56"
- Bottom 'V' maximum diameter 20mm/0.79"

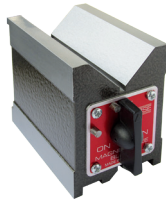

Product Number	Width	Length	Height	Max Clamping Forces	
METRIC					
E934	69.85	101.6	95.25	200	150
E934MP	69.85	101.6	95.25	200	150
E935	69.85	80.0	95.25	160	120
E935MP	69.85	80.0	95.25	160	120
IMPERIAL					
E934	2.75	4.0	3.75	440	330
E934MP	2.75	4.0	3.75	440	330
E935	2.75	3.2	3.75	352	264
E935MP	2.75	3.2	3.75	352	264

## Chuck Blocks

- Supplied in matched and numbered pairs
- May be used vertically or horizontally
- Can be machined to accommodate awkward workpieces
- Can be used to extend flux path of magnetic chuck with parallel poles

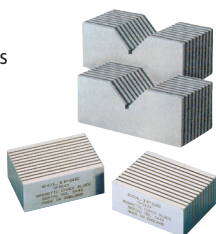

Product Number	Width	Length	Height	Units / Pack
METRIC				
950	75	60	30	1 Matched Pair
950V	100	50	40	1 Matched Pair
IMPERIAL				
950	2.95	2.36	1.181	1 Matched Pair
950V	3.94	1.97	1.574	1 Matched Pair

## Variable Welding Clamp

- Fast accurate holding of ferrous sheets and tubes for welding and assembly work
- Variable from 25° to 280°



Product Number	Length	Height	Width	Pull Force
METRIC	mm	mm	mm	kg
E952	195	200	11	20
IMPERIAL	in	in	in	lbs
E952	7.68	7.87	0.43	44

## Heavy Duty Variable Welding Clamp

- Clamps components during welding, fabrication and assembly
- Powerful 40kg/88lbs clamping force, enables larger components to be clamped with ease



Product Number	Length	Height	Width	Pull Force
METRIC	mm	mm	mm	kg
E974	140	140	35	40
IMPERIAL	in	in	in	lbs
E974	5.51	5.51	1.38	88

## 90° Fixed Welding Clamps

- Two magnetic faces in a rigid 90° angle for jiggling on sheets, pipes and tubes
- A fast and cost effective means of clamping components rigid at 90° angles during fabrication, assembly and weld preparation applications



Product Number	Length	Height	Width	Pull Force
METRIC	mm	mm	mm	kg
E971	140	140	35	40
E972	225	225	22	75
E973	300	300	35	200
IMPERIAL	in	in	in	lbs
E971	5.51	5.51	1.38	88
E972	8.86	8.86	0.87	165
E973	11.81	11.81	1.38	440

## Quick Holding Clamps

- Fast and accurate holding of ferrous metals at different fixed angles
- Also suitable for retrieval applications



Product Number	Length	Height	Width	Pull Force
METRIC	mm	mm	mm	kg
E951	100.5	65.5	12	10
E953	100.5	65.5	20	15
IMPERIAL	in	in	in	lbs
E951	3.95	2.58	0.47	22
E953	3.95	2.58	0.79	33

## Adjustable Links

- Clamp components at any angle for welding and assembly applications



Product Number	Length mm	Height mm	Width mm	Pull Force kg
METRIC	mm	mm	mm	kg
920SU (Single)	60	25	29	12
920 (Pair)	127	25	51	12
IMPERIAL	in	in	in	lbs
920SU (Single)	2.36	0.99	1.14	26.4
920 (Pair)	5.00	0.99	2.01	26.4

## Adjustable Clamping Links

- Clamp components at any angle for welding and assembly applications



Product Number	Length mm	Height mm	Width mm	Pull Force kg
METRIC	mm	mm	mm	kg
920SUOT (Original Type Single)	60	25	29	12
920OTPR (Original Type Pair)	127	25	29	12
IMPERIAL	in	in	in	lbs
920SUOT (Original Type Single)	2.36	0.99	1.14	26.4
920OTPR (Original Type Pair)	5.00	0.99	1.14	26.4

## Mitre Clamps

- Effective and inexpensive method of clamping flat (923) or round (924) ferrous components

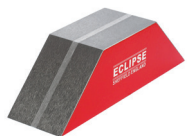

Product Number	Length Base Face	Length Top Face	Height	Width	Pull Force
METRIC	mm	mm	mm	mm	kg
923	156	66	45	43	100
924	184	94	45	43	68
IMPERIAL	in	in	in	in	lbs
923	6.14	2.60	1.77	1.69	220.5
924	7.24	3.70	1.77	1.69	149.9

## Positioners

- 2 magnetic blocks connected by 2 non magnetic steel straps
- The blocks contain ferrite magnetic material
- Magnetic on 2 faces
- On / Off switch located at each end



Product Number	Length	Height	Width	Pull On Flat Face	Pull On V Face
METRIC	mm	mm	mm	kg	kg
922	206.0	63.5	76.0	80	80
IMPERIAL	in	in	in	lbs	lbs
922	8.11	2.50	2.99	176.4	176.4

## Earth Welding Clamp

- Quick and easy earthing for most steel welding operations
- Provides earthing / ground on large welding operations where croc-clip or G-Clamps cannot be easily used



Product Number	Length	Height	Width	Pull Force	Maximum Current
METRIC	mm	mm	mm	kg	amps
E946	193	64	90	25	800
IMPERIAL	in	in	in	lbs	amps
E946	7.60	2.52	3.54	55	800

## Holdfasts

- Supplied with screw release handle
- Can be built into workholding, handling and assembly fixtures to provide a high clamping force and positive grip



Product Number	Diameter	Height	Fixing Holes PCD	Holes	Pull Force
METRIC	mm	mm	mm		kg
E939	44.5	44.5	31.7	2 x M8	20
E940	54.0	49.2	38.1	2 x M8	40
E941	70.0	64.5	50.8	2 x M8	88
E942	101.6	74.6	69.0	3 n/a	183
IMPERIAL	in	in	in		lbs
E939	1.75	1.75	1.25	2 x M8	44
E940	2.13	1.94	1.50	2 x M8	88
E941	2.76	2.54	2.00	2 x M8	194
E942	4.00	2.94	2.72	3 n/a	403

## Weld Holder

- Provides the welder with a powerful, rigid support on flat and round components at various angles during welding preparation applications



Product Number	Length	Height	Width	Pull Force
METRIC	mm	mm	mm	kg
E925	108	140	108	100
IMPERIAL	in	in	in	lbs
E925	4.25	5.51	4.25	220

## Steel Plate Drag

- Used to remove steel sheets from a stack and transport sheets to and from machines
- Contains powerful permanent ferrite magnets in an aluminum housing



Product Number	Length	Height	Width	Vertical Pull Force
METRIC	mm	mm	mm	kg
E964	118	98	38	170
IMPERIAL	in	in	in	lbs
E964	4.64	3.86	1.49	374.8

## Pole Indicator

- Shows the true north or true south pole of magnets
- Pocket sized
- Battery powered - Includes 4 x 1.5v batteries



Product Number	Length	Width	Thickness
METRIC	mm	mm	mm
MPI/100	132	22	19
IMPERIAL	in	in	in
MPI/100	5.19	0.87	0.75

## Magnetic Clip

- Neodymium magnet, plastic clip



Product Number	Size	Material	Colour
METRIC	mm		
E2400	88.9	Neodymium Magnet, Plastic Clip	Red
IMPERIAL	in		
E2400	3.5	Neodymium Magnet, Plastic Clip	Red

## Screwdriver Magnetizer/ Demagnetizer

- Magnetizes and demagnetizes
- Pass small tools through device to magnetize



Product Number	Length	Width	Material
METRIC	mm	mm	
E2500	25.4	25.4	High-Energy Flexible
IMPERIAL	in	in	
E2500	1.0	1.0	High-Energy Flexible

Our Precision range includes magnetic bases for mounting precision measuring equipment and magnetic chucks for machining operations. Each offer quick and easy location while maintaining absolute accuracy.

## Complete Bases & Stands

- Solid holding of precision measuring equipment
- For use in the measurement, inspection, and positioning of workpieces with dial indicators
- All stands will clamp onto curved and flat surfaces, with the exception of E909 (flat only)



Product Number	Product Number NA	Base Part Number	Switching Type	Fitment Part Number	Fitment Type	Hold	Hold
E901	E901	E901WF	Push Button	RP991BL	Heavy duty with fine adjustment	80	176
E903CP	E903CP	E900WF	Push Button	RP72CP	Light duty	30	66
E905	M19713ASS	E905WF (M15885)	Lever	RP995BL	Heavy duty	80	176
E906	M19712ASS	E905WF (M15885)	Lever	RP991BL	Heavy duty with fine adjustment	80	176
E910	E910	E905WF (M15885)	Lever	RP999	Mechanical one piece	80	176
E909	E909	834	Non-switchable	RP909FIT	One pillar	14	31

## Magnetic Bases With Push Button Switch

- Eclipse Magnetics bases can be attached to any ferrous surface to provide a rigid support
- 4 magnetic faces



Product Number	Length	Height	Width	Hole	Hold
METRIC	mm	mm	mm		kg
E900WF	48	52	40	M8	30
E901WF	64	76	64	M8	80
IMPERIAL	in	in	in		lbs
E900WF	1.890	2.047	1.575	M8	66
E901WF	2.519	3.000	2.519	M8	176

## Magnetic Bases With Toggle Switch

- 3 magnetic faces: Top, Bottom, Back



Product Number	Product Number NA	Length	Height	Width	Hole	Hold
METRIC		mm	mm	mm		kg
E905WF	M15885	65	55	50	M8	80
E905WF/100	M19290	75	55	50	M8	100
IMPERIAL		in	in	in		lbs
E905WF	M15885	2.559	2.165	1.969	M8	176
E905WF/100	M19290	2.953	2.165	1.969	M8	220

## Fitment Stands For Bases

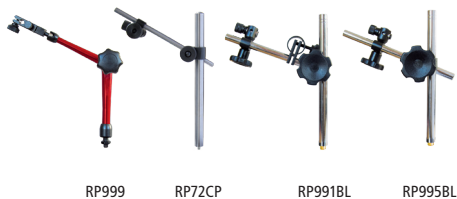

Product Number	Pillar Height	Pillar Diameter	Crossbar Length	Crossbar Diameter	Screw Fixing
METRIC	mm	mm	mm	mm	
RP72CP	185	12.5	150	6.3	M8
RP991BL	175	12.0	165	10.0	M8
RP995BL	175	12.0	165	10.0	M8
IMPERIAL	in	in	in	in	
RP72CP	7.28	0.492	5.90	0.250	M8
RP991BL	6.89	0.472	6.50	0.394	M8
RP995BL	6.89	0.472	6.50	0.394	M8

Product Number	Maximum Extension Height	Screw Fixing
METRIC	mm	
RP999	295	M8
IMPERIAL	in	
RP999	11.6	M8

Premier Range chucks provide precision performance and durability

Eclipse Magnetics invented the first permanent magnet chuck in 1934 and we continue to set the benchmark for quality workholding with today's Premier Range.

## Rectangular

- Unique top plate concentrates magnetic energy on to the chuck face
- The all-metal top plate is extra thick to ensure accuracy after frequent re-grinding
- Chrome plated side and end stops for packing and positioning
- The chucks can be partially magnetized to allow part positioning
- Removable, ergonomically designed handles allow easy switching



Product Number	Length	Height	Width	Pole Pitch	Weight
<b>METRIC</b>					
	mm	mm	mm		kg
AX47/P	203	42	127	17.6	8.2
AX510/P	276	53	129	35.0	16.0
AXS612/P	322	63	151	32.0	22.0
AXS614/P	360	63	151	32.0	22.0
AXS618/P	451	63	151	32.0	36.0
AXM824/P	601	63	201	35.0	56.0
<b>IMPERIAL</b>					
	in	in	in		lbs
AX47/P	7.99	1.65	5.00	17.6	18.1
AX510/P	10.87	2.09	5.08	35.0	35.3
AXS612/P	12.68	2.48	5.95	32.0	48.5
AXS614/P	14.17	2.48	5.95	32.0	48.5
AXS618/P	17.76	2.48	5.95	32.0	79.4
AXM824/P	24.53	2.48	7.91	35.0	101.4

## Circular

- Unique top plate concentrates magnetic energy on to the chuck face
- The chucks can be partially magnetized to aid the correct positioning of the workpiece
- Grooved rings in the top plate assist in visual positioning to aid quick changeover
- Excellent for holding thin ring-shaped components that can be subject to radial distortion

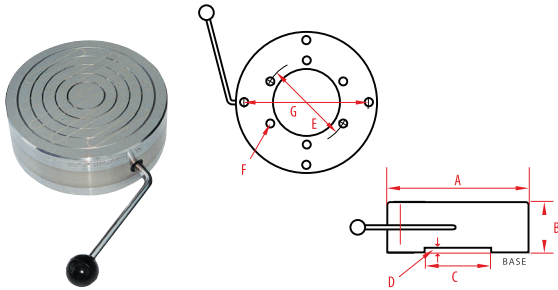

Product Number	A	B	C	D	E	F	G	Weight
<b>METRIC</b>								
	mm	mm	mm	mm	mm	mm	mm	kg
AX475C/P	121	45	51	6.5	76	M6	102	4
AX651C/P	165	60	76	6.5	102	M10	140	10
AX91C/P	229	60	86	6.5	114	M10	191	20
AX12C/P	305	72	152	5.0	184	M12	254	46
<b>IMPERIAL</b>								
	in	in	in	in	in	in	in	lbs
AX475C/P	4.75	1.77	2.00	0.26	3.00	M6	4.02	8.8
AX651C/P	6.50	2.36	3.00	0.26	4.00	M10	5.51	22.0
AX91C/P	9.00	2.00	3.39	0.26	4.50	M10	7.52	44.1
AX12C/P	12.00	2.83	5.98	0.19	7.25	M12	10.00	101.4

## Radial Pole

- Dynamically balanced to enable use at high RPM
- All metal top plate and a rugged industrial build ensures accuracy and longevity
- Through-bored (except NRC100C) allows through-flushing of coolant during machining
- Optional centre plug available

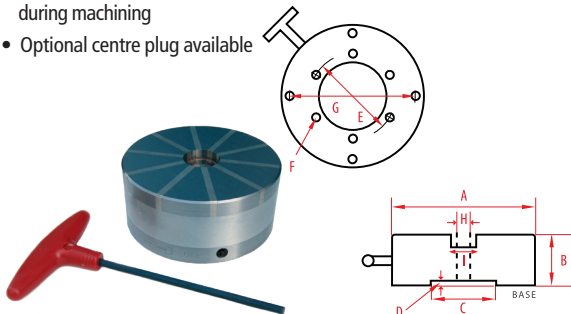

Product Number	A	B	C	D	E	F	G	H	I	No. Of Poles	Weight
<b>METRIC</b>											
	mm	mm	mm	mm	mm	mm	mm	mm	mm		kg
NR100C	100	48	51	6	N/A	M6	76	N/A	N/A	6	3.1
NR150C	150	69	76	4	N/A	M10	102	32	36	10	8.8
NR225C	225	71	86	5	114	M10	191	50	54	14	18.5
NR300C	300	71	152	5	184	M12	254	62	66	18	40.0
<b>IMPERIAL</b>											
	in	in	in	in	in	in	in	in	in		lbs
NR100C	3.94	1.89	2.00	0.24	N/A	M6	3.00	N/A	N/A	6	6.8
NR150C	5.90	2.72	3.00	0.16	N/A	M10	4.02	1.42	1.42	10	19.4
NR225C	8.86	2.80	3.38	0.19	4.48	M10	7.52	2.13	2.13	14	40.8
NR300C	11.81	2.80	5.98	0.32	7.24	M12	10.00	2.60	2.60	18	88.2

Standard Range chucks provide high performance at a competitive price

- Brass and steel top plates
- All chucks are supplied with side and end stops, and with clamps
- Removable hexagon key handles ensure ease of operation through a 180 degree arc
- Clamping force: 80N/cm<sup>2</sup>

## Standard Pole

Pole Spacing: 4.0mm/0.157" steel - 2.0mm/0.079" brass  
Effectively clamps all workpiece thicknesses down to 3mm/0.188"

## Fine Pole

Pole Spacing: 1.5mm/0.060" steel - 0.5mm/0.020" brass  
Ideal for small workpieces less than 3mm/0.188" in height

### Rectangular

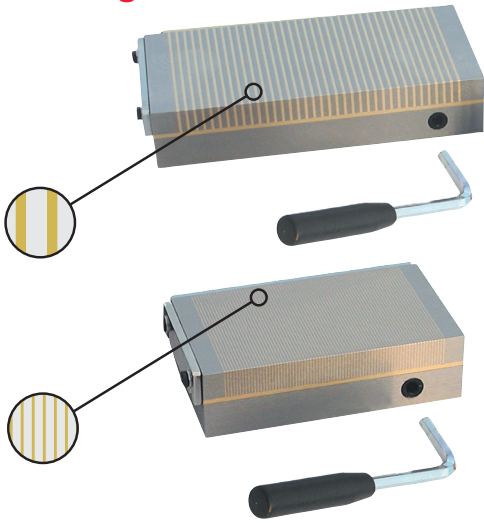

Product Number		Length	Width	Height	Weight
Standard	Fine				
METRIC		mm	mm	mm	kg
	ERFP1018	180	100	50	9.5
	ERFP1530	300	150	50	20.5
	ERFP1535	350	150	50	23.5
ERSP1545		450	150	50	30.0
IMPERIAL		in	in	in	lbs
	ERFP1018	7.09	3.94	1.96	20.9
	ERFP1530	11.81	5.90	1.96	45.2
	ERFP1535	13.78	5.90	1.96	51.8

### Circular



Product Number		A	B	C	D	E	F	G	Weight
Standard	Fine								
METRIC		mm	mm	mm	mm	mm	mm	mm	kg
ECSP100	ECFP100	100	50	50.8	6.35	76.2	M6	N/A	6.0
ECSP125	ECFP125	125	50	50.8	6.35	76.2	M6	101.6	9.4
	ECFP160	160	50	76.2	6.35	101.6	M10	139.7	13.5
ECSP255	ECFP255	255	50	85.7	6.35	114.3	M10	190.5	22.5
IMPERIAL		in	in	in	in	in	in	in	lbs
ECSP100	ECFP100	3.94	1.96	2.00	0.25	3.00	M6	N/A	13.2
ECSP125	ECFP125	4.92	1.96	2.00	0.25	3.00	M6	4.00	20.7
	ECFP160	6.30	1.96	3.00	0.25	4.00	M10	5.50	29.8
ECSP255	ECFP255	10.00	1.96	3.37	0.25	4.50	M10	7.50	49.6



Our range of magnetic lifters are based on failsafe magnetic technology which provides highly efficient and totally safe lifting.

### 3 Patented Safety Features

- Locking switch handle mechanism
- Unique 'Safety Shim' - Pre-test any load to ensure a 3:1 safety factor
- Locking eye mechanism - Magnet cannot be switched off while holding a load



# Ultralift<sup>plus</sup>

Magnetic lifters are quicker, easier and safer to use than slings, chains, hooks and grabs, and do not mark the load.

Onboard switching and permanent magnet technology mean installation and operation could not be easier and running costs are non-existent. Access is only required to the load's top face, allowing for more efficient storage and handling.

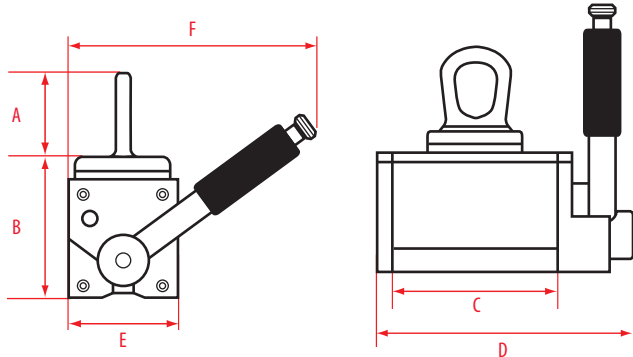

### 3:1 Safety Factor

The patented 'safety shim' allows pre-testing of the load to be lifted irrespective of weight, material, thickness and surface condition.



Product Number	Product Number UK	Self Weight	Dimensions						Material Length Max.	Flat Section		Round Section	
			A	B	C	D	E	F		SWL*	Thickness Min.	SWL*	Diameter Max
IMPERIAL	METRIC	lbs	in	in	in	in	in	in	in	lbs	in	lbs	in
UL0275+	UL0125+	8.8	2.5	2.9	4.0	6.1	2.7	6.0	60	275	0.8	110	8
UL0550+	UL0250+	24.2	3.7	3.8	6.1	8.4	3.6	8.6	60	550	1.0	220	12
UL1100+	UL0500+	59.4	4.8	5.0	8.8	11.8	4.8	10.5	80	1100	1.2	440	16
UL2200+	UL1000+	138.6	5.5	6.9	10.2	14.1	6.9	15.4	120	2200	1.8	880	18
UL4400+	UL2000+	345.4	7.7	8.9	14.5	18.8	9.2	19.4	120	4400	2.8	1760	24

\*Safe working load



## UltraLift LM

### Safe general-purpose lifting

- Lifts up to 4400 lbs (flat) 1760lbs (round)
- Locking switch handle safety mechanism

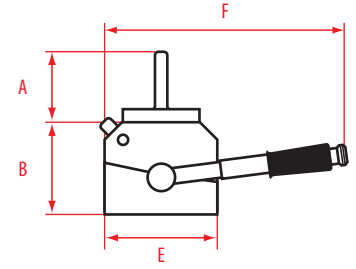

Product Number	Product Number UK	Self Weight	Dimensions						Material Length Max	Flat Section		Round Section	
			A	B	C	D	E	F		SWL*	Thickness Min.	SWL*	Diameter Max
IMPERIAL	METRIC	lbs	in	in	in	in	in	in	in	lbs	in	lbs	in
LM0275	LM0125	9.9	2.1	2.4	4.3	5.9	3.0	5.9	60	275	0.8	110	10
LM0550	LM0250	18.7	3.0	2.8	6.5	8.3	3.5	7.9	60	550	1.0	220	12
LM1100	LM0500	38.5	4.1	3.5	8.9	11.1	4.2	9.6	80	1100	1.2	440	16
LM2200	LM1000	80.3	4.4	4.1	12.8	15.4	5.4	14.4	120	2200	1.8	880	18
LM4400	LM2000	173.8	6.7	5.2	15.7	19.0	7.3	20.7	120	4400	2.8	1760	24

\*Safe working load

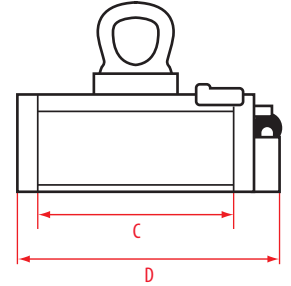

## UltraLift TP

### Thin Plate Lifter

- Lifts up to 880lbs (flat)
- Specifically designed for the safe lifting of thin plate and pressings
- Can lift single sheets from the tops of stacks
- Locking switch handle safety mechanism

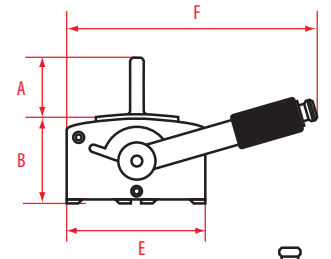

Product Number	Product Number UK	Self Weight	Dimensions						Material Thickness							
			A	B	C	D	E	F	0.20 in		0.25 in		0.30 in		0.40 in	
IMPERIAL	METRIC	lbs	in	in	in	in	in	in	lbs	Length	lbs	Length	lbs	Length	lbs	Length
TP330	TP150	18	3	3	6	8	4	7	165	60	220	60	330	60	440	60
TP660	TP300	33	3	3	12	14	4	7	330	80	440	80	660	80	880	80

\*Safe working load

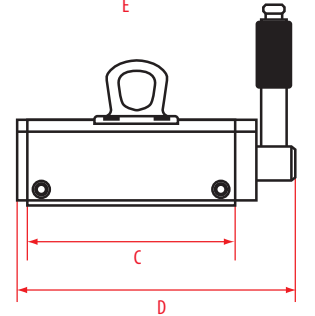

## Service and Maintenance

### Full inspection and certification

- Free inspection and quotation
- Certificate of performance for magnetic lifters to satisfy H & S audits
- Spare parts available

\*All lifting systems should be serviced every 12 months by a competent person. Our fully trained personnel provide a full inspection and certification service. Please refer to manual guidelines for inspection requirements.

**For more details, call us at 1-800-260-2124**



A high performance range of electromagnets for design engineering projects, e.g. access control systems, medical devices, hold and release automation systems, and machine guards.

## Energize to Hold Power required to turn magnet ON. Power removed to turn magnet OFF.

- Sturdy bright nickel plated cylinder, passivated with body mounting
- High-quality permeable iron for low remanence
- Armature plates to suit

Operating Voltage 12VDC & 24VDC  
 Connector Options Flying leads, two-pole connector  
 Mounting Threaded holes in magnet rear face  
 Finish Bright nickel plated with machined face  
 ED Rating 100%  
 IP Rating 54 (20 for the two-pole connector)

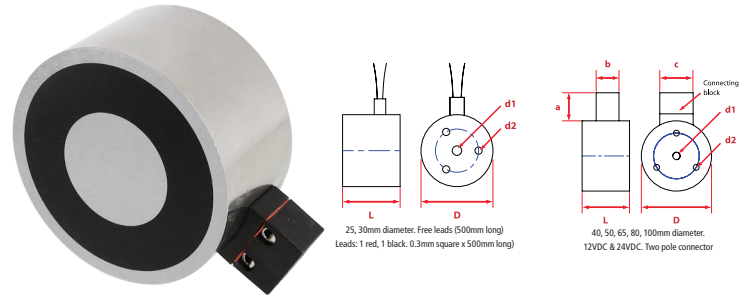

		Standard Operating Voltage				D	L	a	b	c	d1	d2	PCD	Pull at Zero Air Gap
METRIC		24VDC Product Number	Current mA	12VDC Product Number	Current mA	mm	mm	mm	mm	mm			mm	kg
Diameter mm	25	M52172/24VDC	90	M52172/12VDC	180	25	20	-	-	-	M4	M3	15	11.3
	30	M52173/24VDC	140	M52173/12VDC	280	30	24	-	-	-	M5	M3	18	25.3
	40	M52174/24VDC	230			40	27	16	13	19	M5	M4	26	57.5
	50	M52175/24VDC	240			50	30	16	13	19	M5	M4	34	109.7
	65	M52176/24VDC	340			60	35	16	13	19	M8	M5	40	167.7
IMPERIAL		24VDC Product Number	Current mA	12VDC Product Number	Current mA	in	in	in	in	in			in	lbs
Diameter in	0.984	M52172/24VDC	90	M52172/12VDC	180	0.984	0.787	-	-	-	M4	M3	0.590	24.9
	1.181	M52173/24VDC	140	M52173/12VDC	280	1.181	0.945	-	-	-	M5	M3	0.709	55.8
	1.575	M52174/24VDC	230			1.575	1.063	0.62	0.51	0.74	M5	M4	1.023	126.8
	1.969	M52175/24VDC	240			1.969	1.181	0.62	0.51	0.74	M5	M4	1.339	241.9
	2.559	M52176/24VDC	340			2.559	1.378	0.62	0.51	0.74	M8	M5	1.575	369.8

## Energize to Release Power required to turn magnet OFF. Power removed to turn magnet ON.

- Sturdy bright nickel plated cylinder, passivated with body mounting
- High-quality permeable iron for low remanence
- Armature plates to suit

Operating Voltage 24VDC (with rectified plug connector)  
 Connector Options Hirschman connector  
 Mounting Central machined hole in rear face of magnet  
 Finish Bright nickel plated with machined face  
 IP Rating 54  
 Duty Cycle S2

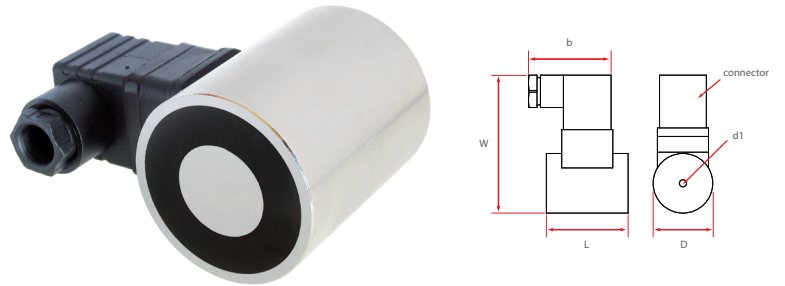

		Standard Operating Voltage			D	W	L	b	d1	Pull at Zero Air Gap
METRIC		24VDC Product Number	Current mA		mm	mm	mm	mm		kg
Diameter mm	35	M52177/24VDC	240		35	78	48	50	M5	28.5
	50	M52178/24VDC	350		50	94	63	50	M5	47.1
IMPERIAL		24VDC Product Number	Current mA		in	in	in	in		lbs
Diameter in	1.378	M52177/24VDC	240		1.378	3.070	1.890	1.968	M5	62.8
	1.968	M52178/24VDC	350		1.968	3.700	2.480	1.968	M5	103.8

## Armature Plates

- To fit both types



Product Number	Diameter	Height	Screw	Product Number	Diameter	Height	Screw
METRIC				IMPERIAL			
M52171/25ARM	25	3	M3	M52171/25ARM	0.984	0.118	M3
M52171/30ARM	30	4	M4	M52171/30ARM	1.181	0.157	M4
M52171/40ARM	40	5	M4	M52171/40ARM	1.575	0.197	M4
M52171/50ARM	50	6	M4	M52171/50ARM	1.969	0.236	M4
M52171/65ARM	65	8	M5	M52171/65ARM	2.559	0.315	M5

To achieve the optimum pull force, 100% contact area must be achieved using the recommended armature plate. The force will be affected if other material specifications, thickness and surfaces are used, or if the armature fails to make positive contact over the full diameter of the face of the magnet. Where misalignment is likely to be an issue we recommend that an oversized armature plate is used to ensure 100% full contact, this however will reduce the stated pull force by approximately 10%

# Guide To Magnet Materials

## When choosing a magnet material for an application you should take the following factors into consideration:

- Flux requirement of the application
- Maximum operating temperature
- Likely exposure to corrosive conditions
- Magnetic stability
- Size and weight limitations

## What strength/flux of magnet do you need?

This table shows the comparative magnetic strengths of the same volume of the four main magnet materials in terms of their maximum energy products (BHmax) in CGS or SI units and their typical pole face flux densities.

Neodymium is the most powerful magnet material available. It is ideal for applications where high flux density is required or where space is at a premium.

Magnet Material	Max Energy Product: CGS	Max Energy Product: SI	Flux Density
Ferrite	3.3 MGOe	26 KJ/m <sup>3</sup>	1000 Gauss
Alnico	5.2 MGOe	42 KJ/m <sup>3</sup>	1300 Gauss
Samarium Cobalt	26 MGOe	208 KJ/m <sup>3</sup>	3500 Gauss
Neodymium	35 MGOe	279 KJ/m <sup>3</sup>	4500 Gauss

## What temperature will the magnet be operating in?

In most applications, operating temperature is not a consideration but extreme temperatures will have an effect on the magnetic performance.

Each material has different temperature characteristics and these must be reviewed to ensure that the correct material is used for the application. Using the wrong material could lead to loss in magnetic performance.

## Other Factors To Consider

### Corrosion

Another potential cause of performance loss is a breakdown of the magnet's composition due to corrosive environmental effects. This table shows relative corrosive resistance for each material when uncoated. As neodymium's corrosive resistance is poor it is usually sold with a protective coating, normally either nickel or zinc.

Magnet Material	Corrosion Resistance Uncoated	Resistance To Demagnetisation
Ferrite	Excellent	High
Alnico	Fair	Low
Samarium Cobalt	Excellent	Very High
Neodymium	Poor	Very High

### External Demagnetising Fields / Magnet Stability

Temperature has the greatest effect on magnet stability but high external magnetic fields can influence performance. This table shows the relative demagnetising effect on each material.

**Please note, this guide provides general information only.**

**For specific information please contact us at 1-800-260-2124**

In addition to the products in this catalogue, Eclipse Magnetics are innovators in other fields:



## Contamination Removal Systems

Full range of products and services to protect all process lines and products from foreign body contamination.

- Magnetic separators
- Vibratory sieves
- Metal detectors
- Site audits



## Magnetic Filtration Systems

Highly efficient magnetic systems for removing ferrous contamination from industrial fluids such as coolants, oils, and lubricants.



## Material Handling And Workholding

Extensive range of products that improve safety and increase efficiency when lifting, holding, moving or clamping ferrous materials, workpieces, tools, and components.



## BoilerMag

Magnetic filters for removing ferrous oxide contamination from industrial heating systems.



Eclipse Tools North America Inc.

442 Millen Road, Unit 9 | Stoney Creek | ON L8E 6H2

☎ 1-800-260-2124 📠 1-800-260-1410 🌐 [www.eclipsemagnetics.com/na](http://www.eclipsemagnetics.com/na) ✉ [sales@eclipsetoolsinc.com](mailto:sales@eclipsetoolsinc.com)

While every effort has been made to ensure the accuracy of the information within this publication, please note that specifications may change without notice.