

Specifications

Drawing No.	USY1N-H1-23100-00
Issued Date.	Sep,05.2023

Messrs: Kyocera AVX

Note: Part numbers may be revised in the event of any specifications change.

Product Type	Tuning Fork Crystal
Series	DT2012SB
Frequency	32.768kHz
Customer Part Number	-
Customer Specification Number	-
KYOCERA Part Number	DT2012SB32768C0HPWAA
Remarks	Pb-Free, RoHS Compliant, MSL 1

Customer Approval

Approval Signature	Approved Date	
	Department	
	Person in charge	

Seller

KYOCERA Corporation

Corporate Electronic Components Group
Electronic Components Sales Division
6 Takeda Tobadono-cho, Fushimi-ku, Kyoto
612-8501 Japan
TEL. No. 075-604-3500 FAX. No. 075-604-3501

Manufacturer

Corporate Electronic Components Group
Electronic Devices Division
Shiga Yohkaichi Plant
1166-6 Hebimizo-cho, Higashiomi, Shiga
527-8555 Japan
TEL: 81-748-22-1550 FAX: 81-748-22-1590

Design Department	Quality Assurance	Approved by	Examined by	Written by
KYOCERA Corporation Corporate Electronic Components Group Electronic Devices Division	E.Kimura	A.Iwaguchi	K.Takahashi	H.Ebara

Revision History

Rev.No.	Description of revise	Date	Approved by	Examined by	Written by
00	First Edition	Sep,05,2023	A.Iwaguchi	K.Takahashi	H.Yasunaga

1. APPLICATION

This specification sheet is applied to tuning fork crystal "DT2012SB".

2. KYOCERA PART NUMBER

DT2012SB32768C0HPWAA

3. RATINGS

Items	SYMB.	Rating	Unit
Operating Temperature	Topr	-40~+85	°C
Storage Temperature range	Tstg	-40~+85	°C

4. CHARACTERISTICS

4-1 ELECTRICAL CHARACTERISTICS

Item	Symbol	Electrical Specification				
		Condition	Min	Typ.	Max	Unit
Nominal Frequency	fo	Ta = 25°C		32.768		kHz
Frequency Tolerance	df/fo	Ta = 25°C ± 3°C	-20	-	20	ppm
Load Capacitance	CL		-	7.0	-	pF
Equivalent series resistance	R1		-	-	80	kΩ
Q-Value	Q		-	16000	-	
Motional capacitance	C1		-	5.4	-	fF
Shunt capacitance	Co		-	1.3	-	pF
Turning point	Tp		20	25	30	°C
Secondary temperature Coefficient	K		-	-	-0.04	10 ⁻⁶ /°C ²
Aging	df/F	Ta = 25°C	-5	-	5	ppm/year
Drive level	DL		-	0.1	0.5	μW
Insulation resistance (between electrodes)	IR	DC 100 ± 15V	500			MΩ

5. APPEARANCES, DIMENSION

OUTLINE DIMENSIONS (not to scale) (TOP VIEW)

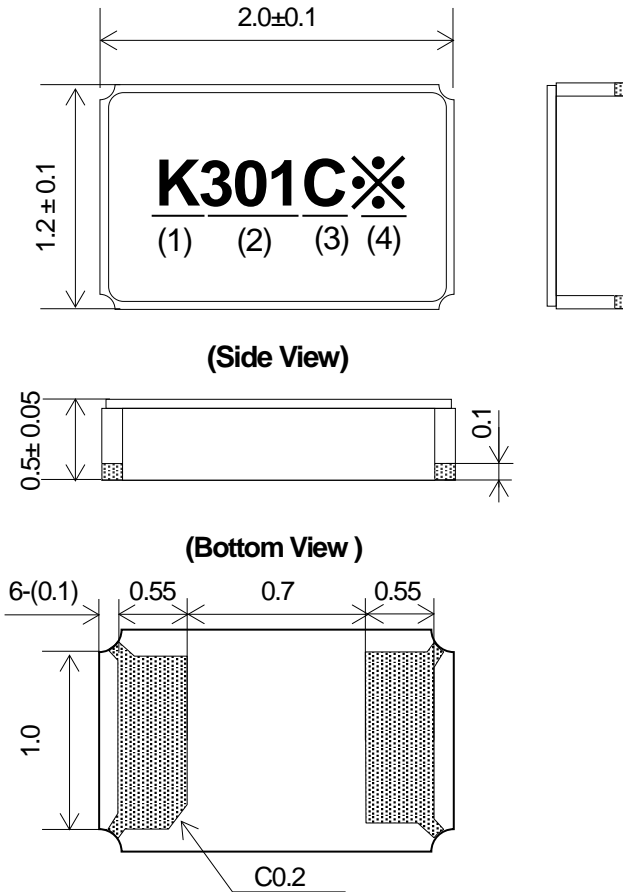

UNIT : mm

MARKING

- | | |
|-----------------------------|--|
| (1.) Identification | K |
| (2.) Date Code (3 Digits) | Last 1 digit of year and week Code.
(Ex) 2023.Jan.1 → 301 |
| (3.) Load Capacitance | (Ex) 7.0pF → C |
| (4.) Manufacturing Location | Overseas → C, Japan → T |
- *The font of marking above is for reference purpose.

6. RECOMMENDED LAND PATTERN

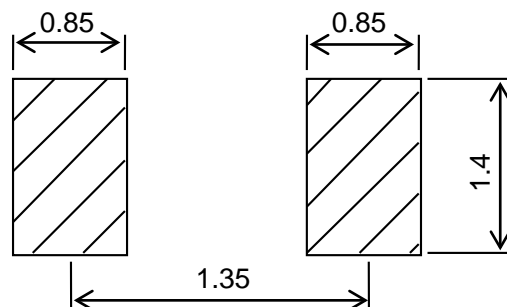

UNIT : mm

7. TAPING

7.1 Specification

1. Material of the carrier tape is polystyrene and carbon.
2. Material of the cover tape is polyester.
3. The seal tape shall not cover the sprocket holes and not protrude from the carrier tape.
4. The alignment between centers of the cavities and sprocket holes is 0.05mm or less.
5. The orientation shall be checked from the top cover tape side.
6. Peeling force of the cover tape: 0.1 to 0.7N.

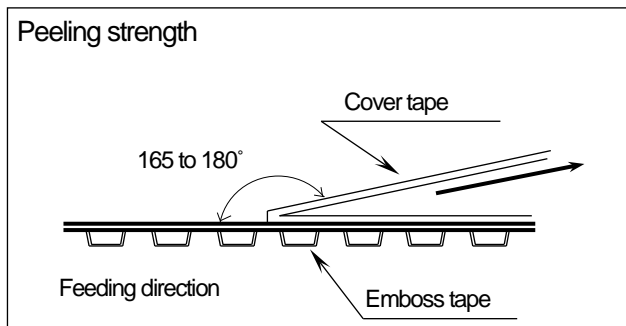
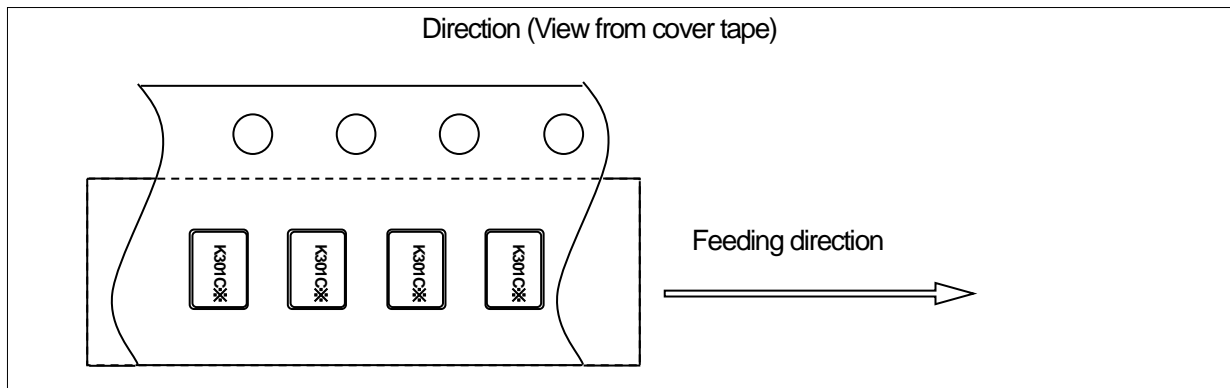
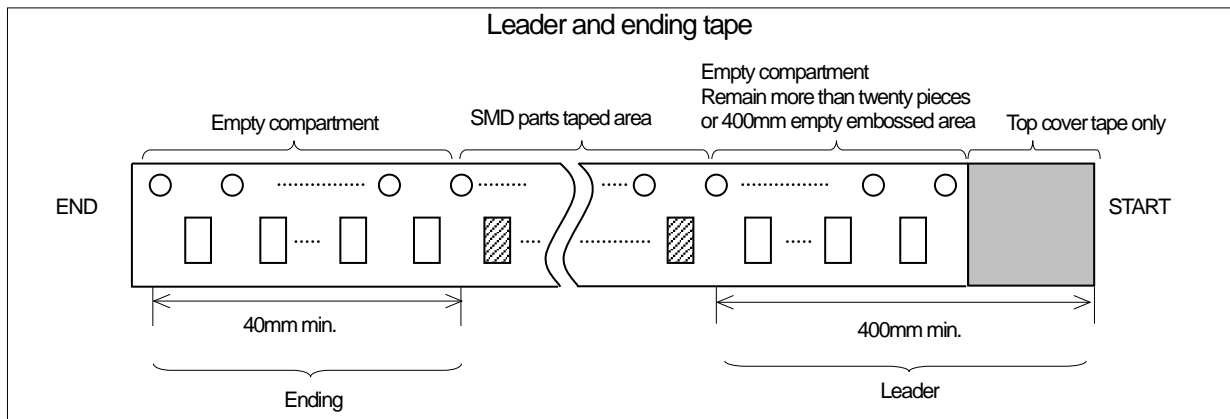

7-2 Emboss Taping specifications

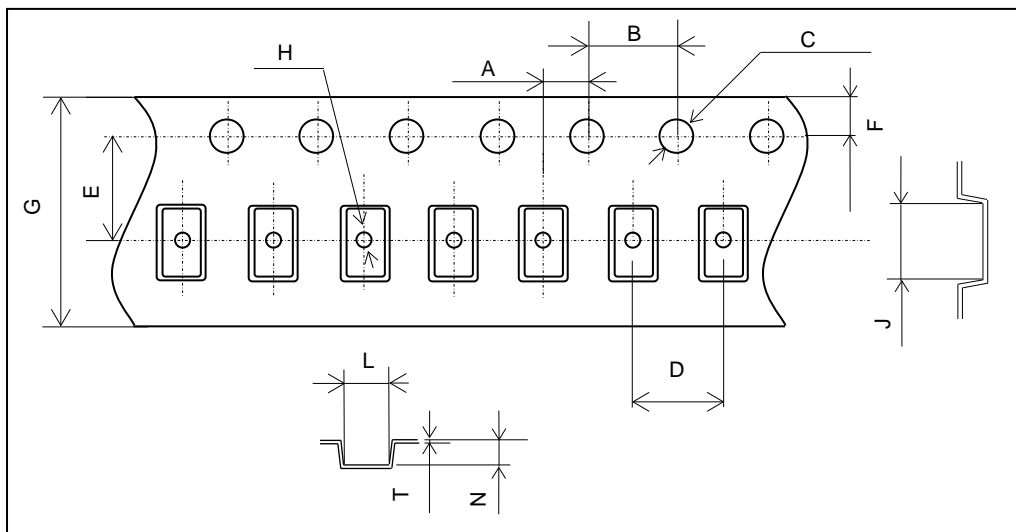

symbol	A	B	C	D	E	F
Dimension	2.0±0.1	4.0±0.1	1.55±0.05	4.0±0.1	3.5±0.05	1.75±0.1
Symbol	G	H	J	L	N	T
Dimension	8.0±0.2	φ1.05±0.05	2.3±0.1	1.45±0.1	0.65±0.1	0.20±0.05

(Unit: mm)

7-3 Reel specifications

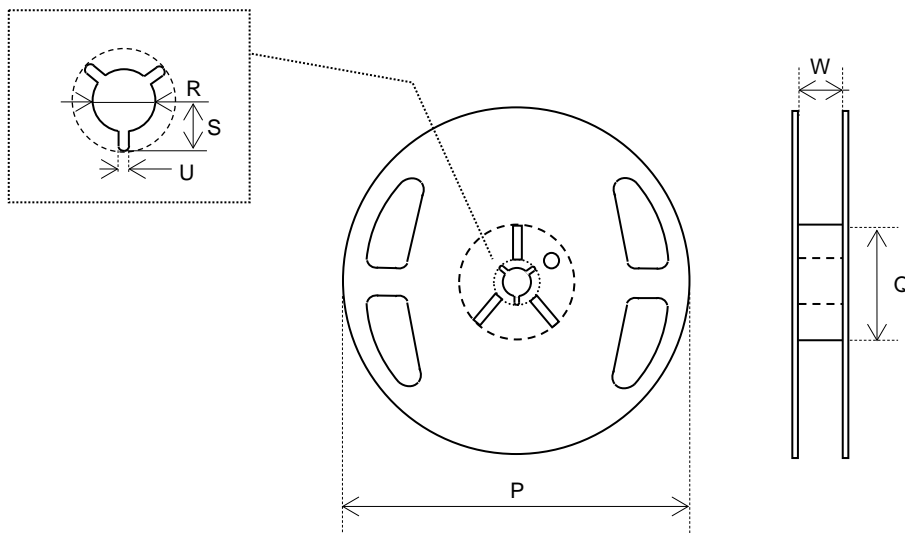

φ180 Reel (3,000 pcs Max.)

Symbol	P	Q	R
Dimension	φ180+0.0/-3.0	φ60+1.0/-0.0	φ13±0.2
Symbol	S	U	W
Dimension	10.5±0.4	2.0±0.5	9.0±0.3

(Unit: mm)

8.Environmental requirements

- 8.1 Shock(Mounting Drop) After the following test, parts shall conform specification table-1-A.
 10cycles(60times) drop from 150cm heights to concrete.
 Further, parts shall be soldered on substrate, fixed aluminum materials(about 100g)
 Substrate materials : FR-4, t=1.6mm
 1cycle : each 1time of 6directions
- 8.2 Shock(Acceleration) After the following test, parts shall conform specification table-1-A.
 1000m/s² by 6ms X,Y,Z each axis (6directions), 10cycles
- 8.3 Vibration After the following test, parts shall conform specification table-1-A
 and no abnormal appearance shall be observed.
 (1)Frequency of Vibration : 10~2000Hz
 (2)Amplitude total : sine waves of 1.5mm (10~55Hz) and 200m/s² (55~2000Hz)
 (3)Vibration axis : X,Y,Z
 (4)Vibration period : 2h for each axis
 (5)Cycle : 20minAfter the Test condition
- 8.4 High Temperature 2h past at room temperature after following test, parts shall conform specification table-1-C. 240h +85±2°C Test condition
- 8.5 Low Temperature 2h past at room temperature after following test, parts shall conform specification table-1-B. 240h -40±2°C
- 8.6 Humidity 2h past at room temperature after following test, parts shall conform specification table-1-C. 240h +85±2°C, relative humidity 85±5%
- 8.7 Temperature Cycle 2h past at room temperature after 200cycles of following test, parts shall conform specification table-1-C.

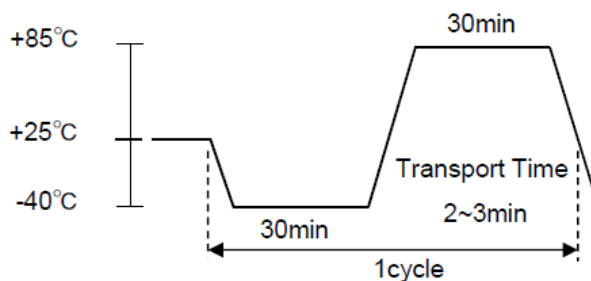

8.8 Reflow condition

Reflow temp.profile

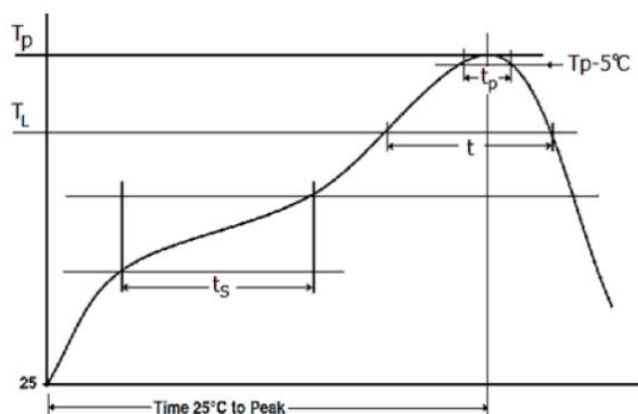

ts [°C]	150 to 200
ts time [s]	60 to 120
TL [°C]	217
t time [s]	60 to 150
Tp [°C]	Max. 260
Tp [s]	Max. 30

Reflow soldering shall be allowed only 3times.

48h past at room temperature from following test, parts shall conform specification table-1-B.

8.9 Bending Strength

After the following test, parts shall conform specification table-1-A and no abnormality shall be observed in external appearance and sealing tightness and others shall be based on ET-7403 of EIAJ.

Solder this product onto the center of a 40mm × 100mm circuit board, and add a deflection of 3mm as shown below.

- Test board : FR-4, t=1.6mm
- Speed : 1.0mm/s
- Hours : 5±1s

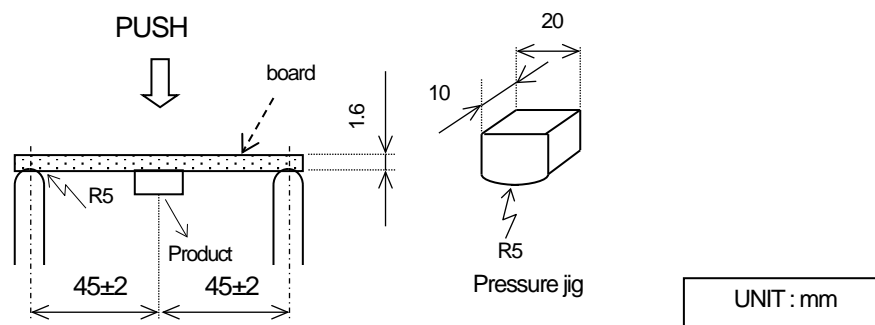

8.10 Specification

Table-1

	Frequency variation	Series resistance variation
A	±5 × 10 ⁻⁶	±10kΩ
B	±10 × 10 ⁻⁶	±10kΩ
C	±15 × 10 ⁻⁶	±10kΩ

9. Cautions for use

(1) Soldering

Characteristics may be affected when Solder paste or conductive glue comes in contact with product lid or surface. Please perform reflow temp. profile within 3times.

(2) When using mounting machine

Crystal products are designed to be compatible with automatic mounting. Be sure to have a mounting test in advance by using the actual mounting machine and check that the characteristics of the products are not damaged by the automatic mounting. In the process where the board is warped, such as board separation process, be careful that the warping does not influence the characteristics and soldering of crystal products. Since mounting by Ultrasonic Welding and processing have a possibility of an excessive vibration spreading inside a tuning fork crystal resonator and becoming the cause of characteristic deterioration and not oscillating, it does not recommend. Please repair at +260°C in 10s within hot air.

(3) Conformity of a circuit

We strongly recommend to make sure that Negative resistance (Gain) of IC is designed to be 3 times the ESR (Equivalent Series Resistance) of Crystal unit.

(4) Washing

About use of the washing liquid of a basin system, an alcoholic system, and a chlorofluorocarbon-replacing material system, it is checking that it is satisfactory. However please consult in advance about other washing liquid. Tuning fork crystal resonators should not have ultrasonic washing because their frequency band is close to the washing frequency band of ultrasonic washing machines, very probably causing resonance destruction. To use ultrasonic washing to clean these resonators, tests must be performed in advance under actual application conditions.

(5) Drive Level

The piece of crystal it is processed very smaller than the conventional thing inside DT2012SB series crystal unit may be damaged, if crystal resonators are exposed to an excessively high drive level. Please use the products within the limits specified in the catalogs and specifications.

(6) Handling of a product

DT2012SB series has sufficient intensity to fall and vibration. However, if a crystal product is pressed hard, be sure to check for any damages before using. Crystal resonators should not have pattern to avoid causing base crack.

(6) Application instructions

This product is designed to be used for general electronic device and is not designed in the high reliability application listed below.

Please inform the department in charge when using the product for following applications.

Utility in nuclear power plant	Traffic signal control system
Utility in space	security and disaster-prevention
Aircraft	Transporter (car, train, ship, etc.)
under water or ground	Medical
other - applications requires same environmental status as above.	

This product must not be used in every application which are primary - intended to damage human race or their property.

Arms (missile, bomb and other application to damage human)
 Weapons (transports act for combat)
 Controller with primary – intended to military use.

10. Storage conditions

Please store product in below conditions, and use within 6 months.
Temperature +40°C max., and Humidity of 80% in the packaging condition.

11. Quality Assurance

Location
KYOCERA Corporation Shiga Yohkaichi Plant: Quality Assurance Division

12. Quality guarantee

In the case when KYOCERA Corporation rooted failure occurred within 1 year after its delivery, substitute product will be arranged based on discussion. Quality guarantee of product after 1 year of its delivery is waived.

13. Others

In case of any questions or opinions regarding the Specification, please have it in written manner within 45 days after issued date.