

The **SLB Series** is designed to protect three-phase equipment against **PHASE UNBALANCE, PHASE LOSS, and PHASE REVERSAL** conditions.

OPERATION

With normal operating voltages in the proper ABC sequence and the 120 VAC control voltage applied, the internal relay will energize (PICK-UP). When any combination of Phase Unbalance exceeding the preset value or Phase Loss or Phase Reversal occurs for longer than the preset drop out time, the output relay will de-energize (DROP-OUT). If the control voltage is removed, the relay will de-energize.

The wide input voltage range permits use on any one of several standard line voltages without recalibrating. The unbalance detection level is adjustable from 2% to 15%.

Both Delta and Wye systems may be monitored. In Wye systems, connections to neutral are not required.

The LED indicator glows when conditions are normal.

NOTE: A balanced condition exists and the output relay will energize when there is a complete absence of voltage on all three phases (Terminals 1, 3 and 5) and the control voltage is continuously applied to (Terminals 11 and 12). For this reason, the SLB series is ideally suited for **LOAD SIDE MONITORING APPLICATIONS**.

SPECIFICATIONS

- OUTPUT RATING** SPDT, 10 Amps @ 120 VAC,
5 Amps @ 240 VAC, Resistive
- PHASE SEQUENCE** ABC (Will Not Operate CBA)
- OPERATING VOLTAGE** See Table Below
- CONTROL VOLTAGE** 120 VAC, 1 Phase, 60 Hz
- POWER REQUIRED** 3 VA, Max.
- PHASE UNBALANCE RANGE** 2% to 15%, Adjustable
- INDICATORS LED** Glows When All Conditions Are Normal
- RESPONSE TIMES** Operate 60 mSEC, Fixed
Release 0.1 to 5 SEC, Adjustable
- TEMPERATURE RATING** Operate 32° to +104°F (0° to +40°C)
Storage -49° to 185°F (-45° to +85°C)
- ENCLOSURE** Style "E" LEXAN® Surface Mount
- WEIGHT** 1 lb. 2 oz.

The SLB Series will not detect an equal and simultaneous reduction in voltage on all three lines (Brown Out).

MODEL NUMBER	OPERATING VOLTAGE	RESET	HYSTERESIS
SLB-200-ALEA	Standard 0-300; 3 Ø Line Voltages	Automatic	10% of Unbalance Setting
SLB-200-ALER	60 Hz.	Manual	None
SLB-400-ALEA	Standard 300-500; 3 Ø Line Voltages 60 Hz	Automatic	10% of Unbalance Setting

All voltages referenced on this page are phase-to-phase.

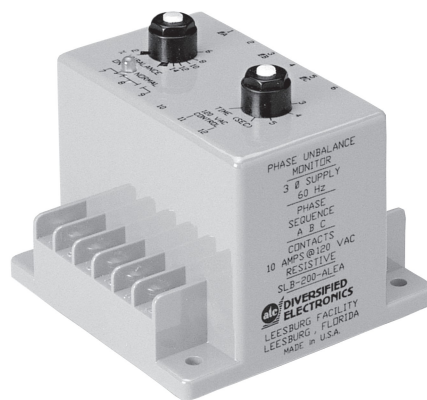

Phase Unbalance Monitor

DIMENSIONS (INCHES)

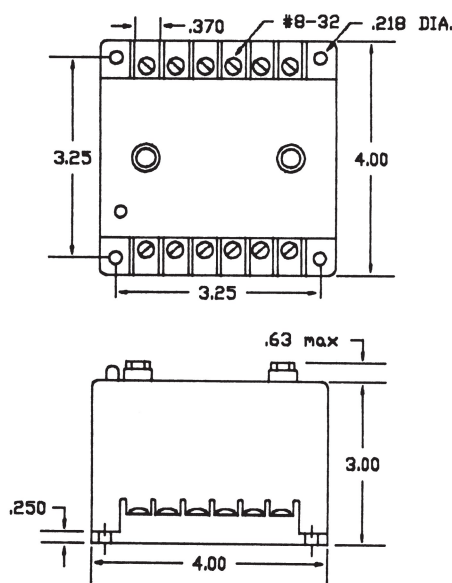

WIRING

