

This specification describes the performance characteristic of a wide input range (280Vdc~880Vdc) 3000W power supply module with +27.5V/110A DC output.



Contents

Features	2
Applications	2
Model List	2
Input Characteristics	2
Input Voltage	2
Input Current	2
Standby Current	2
Peak Efficiency	3
On-off Control	3
Output Characteristics	3
Output Load Ratings	3
Ripple & Noise	3
Turn-on Delay Time	4
Turn-on overshoot range	4
Dynamic Load Response	4
Input Voltage Regulation	4
Load Regulation	4
Protection Functions	4
Input Over Voltage Protection	4
Input Under Voltage Protection	4
Output Over Voltage Protection	4
Output Under Voltage Protection	5
Output Current limitation	5
Short Circuit Protection	5
Over Temperature Protection	5
Reverse Input Polarity Protection	5
Fault Log	5
Safety & EMC Compliance	5
Block Diagram	6
Performance Curves	6
Mechanical Specification	7
Dimension and Outline Drawing	7
Aux power & Signal Ports	7
Package	8
Revision History	8

Features

- For Electric Vehicle on board application
- 280~880Vdc wide input range
- +27.5V/110A 3000W output power with high efficiency
- -40~85°C wide operation temperature range
- Comprehensive monitoring and protection base on CAN bus communication

SMPS Adaptor (Wall-Mount)

Open Frame

Others

SMPS Adaptor (Desktop)

SMPS Unit (With Case)

Applications

Automotive DC/DC power supply

Model List

PLD3000-EVDYL02(A)-27

Input Characteristics

All data tested under 25 °C ambient temperature, unless otherwise specified.

Input Voltage

Input	Min.	Typ.	Max.
Input voltage	280Vdc	540Vdc	880Vdc
Auxiliary input voltage	18Vdc	24Vdc	32Vdc

*Output derating at 280~380Vdc input. Derating curve refer to the Performance Curves section.

**No damage under 900Vdc input.

Input Current

Max continuous input current: 12A RMS

Standby Current

Standby current: $\leq 10\text{mA}$ @ 880Vdc input & standby mode

Peak Efficiency

Peak efficiency: >95% @ 540Vdc input & ≥50% Load

On-off Control

Output on/off is controlled by a PSON signal or CAN communication, while the PSON signal have the control priority. The PSON signal and CAN protocol will be specified in other files.

Output Characteristics

All data tested under 25 °C ambient temperature, unless otherwise specified.

Output Load Ratings

Output voltage	Output current
+27.5±0.5V	0~110A

*Output power will derate under the cases below

- 1) 280~380Vdc input
- 2) T_{base} derating
- 3) Error for derating

V_o error: ±2V, V_{in} error: ±15V or ±5%, T_{base} ±5°C

Ripple & Noise

Output	+27.5V / 110A (Full load)
Maximum ripple/noise	500mVp-p *

* measured at the output edge of power supply, measuring setup described as bellow:

20MHz BW, 0.1uF X7R MLCC + 10uF e-Cap

Measurements will be made with an oscilloscope set to 20MHz-bandwidth limit. The outputs will be bypassed with one 0.1uF ceramic cap (type X7R) and one 10uF (low ESR) electrolytic capacitor.

Outputs will be tested per the setup in the Figure below.

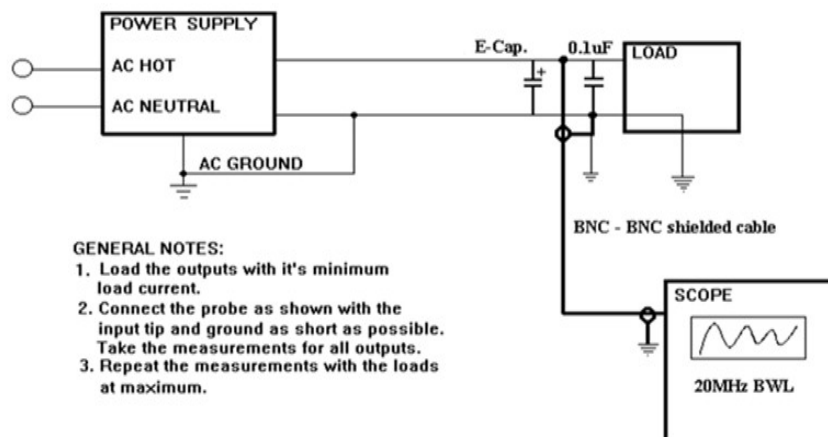

Turn-on Delay Time

Turn on delay: $\leq 3s$ after CAN or the PSON signal is applied

Turn-on overshoot range

Turn-on Overshoot: $\leq 5\%$ @ 540Vdc input $\geq 50\%$ Load

Dynamic Load Response

Recovery time	≤ 10 ms	* 27.5V output
Over/undershoot	$\pm 5\%$	* load transition 25%-50%-25%/50%-75%-50%, 0.1A/us

Input Voltage Regulation

Input Voltage Regulation: $\leq \pm 1\%$ @ half Load, 380~880Vdc input

Load Regulation

Load Regulation: $\leq \pm 1\%$ @ 540Vdc input, all load range

Protection Functions

All protections are detected by MCU and can be reset by CAN or PSON signal.

Input Over Voltage Protection

Turn off threshold: 910 ± 20 Vdc

Recovery threshold: 860 ± 20 Vdc

Input Under Voltage Protection

Turn off threshold: 260 ± 15 Vdc

Recovery threshold: 270 ± 15 Vdc

Output Over Voltage Protection

Turn off threshold: 33 ± 2 Vdc

Output Under Voltage Protection

Turn off threshold: $\leq 20 \pm 2V$, $\geq 1\text{sec}$

Output Current limitation

Current limit: $115 \pm 5A$

Short Circuit Protection

Turn off threshold: CC output ($115 \pm 5A$) & $V_o \leq 15V$, $\geq 2\text{sec}$

Over Temperature Protection

TNTC turn off threshold: $> 130 \pm 5^\circ\text{C}$

TNTC Recovery: $85 \pm 5^\circ\text{C}$

Reverse Input Polarity Protection

No output, no damage.

Fault Log

Last 5 faults can be recorded on the EEPROM.

Safety & EMC Compliance

Category		Standard	
Hipot	In-out	3500Vdc	3500Vdc, 1min, leakage < 10mA No arcing
	In-case	2000Vdc	2000Vdc, 1min, leakage < 10mA No arcing
	Out-case	500Vdc	500Vdc, 1min, leakage < 10mA No arcing
Insulation Resistance	In – out, In-case	$\geq 20M\Omega @ 500Vdc$	500Vdc & normal air pressure, 90% Humidity
EMC	RE/CE	EN55025/GB18655, class 3, tested with customer system.	
	Immunity	95/54/EC(1995)/ GB/T 17619-1998, tested with customer system.	
	ESD	$\pm 8kV$ air, $\pm 6kV$ contact for case and input, output, signal ports.	

Block Diagram

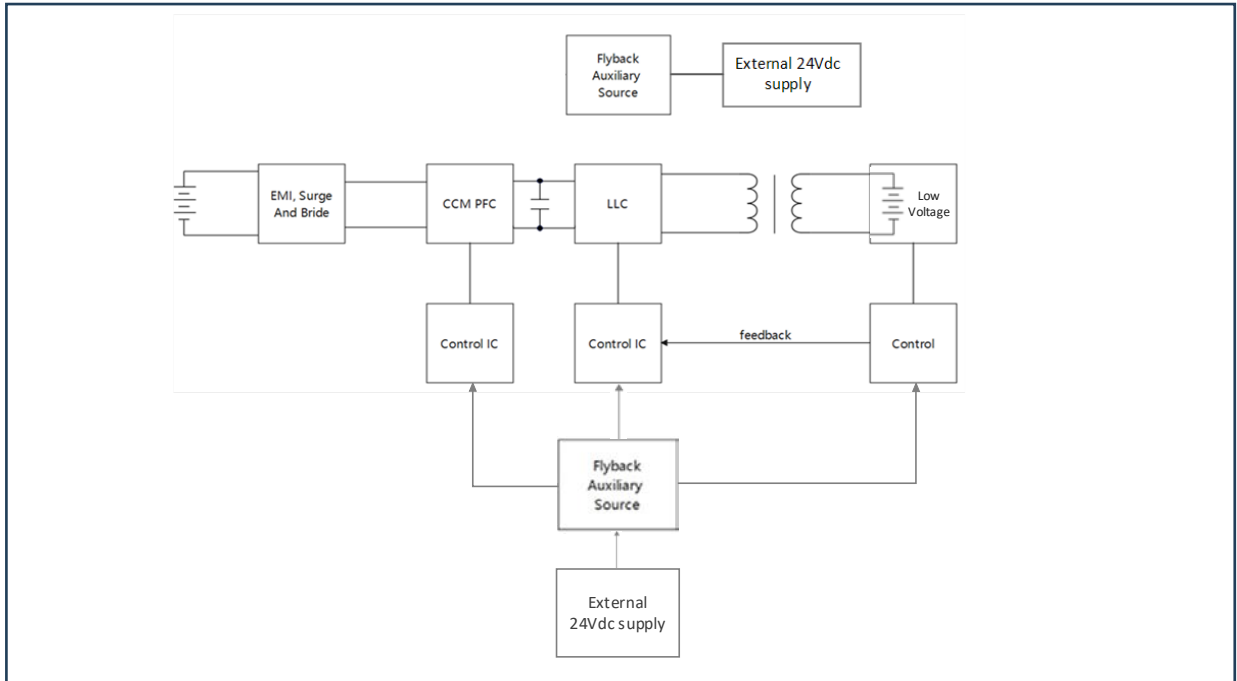

Performance Curves

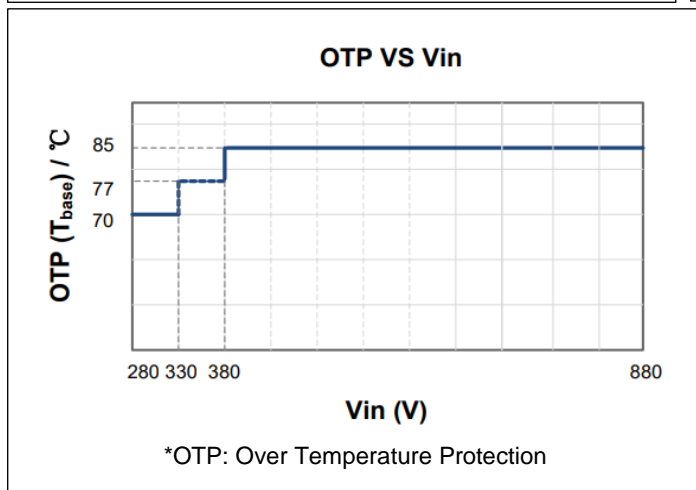
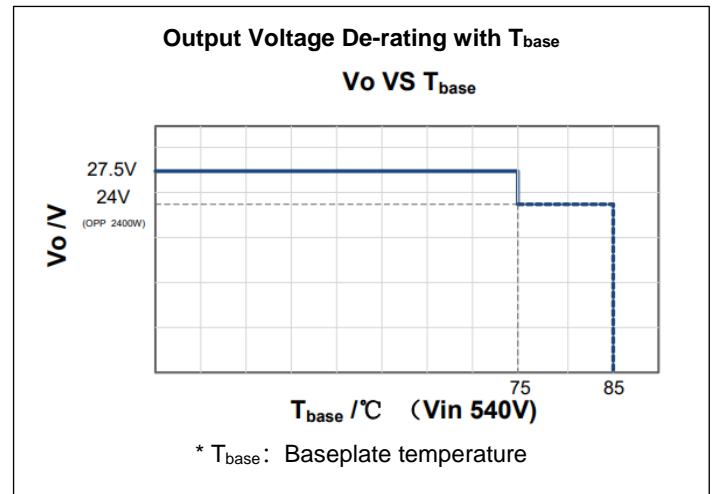
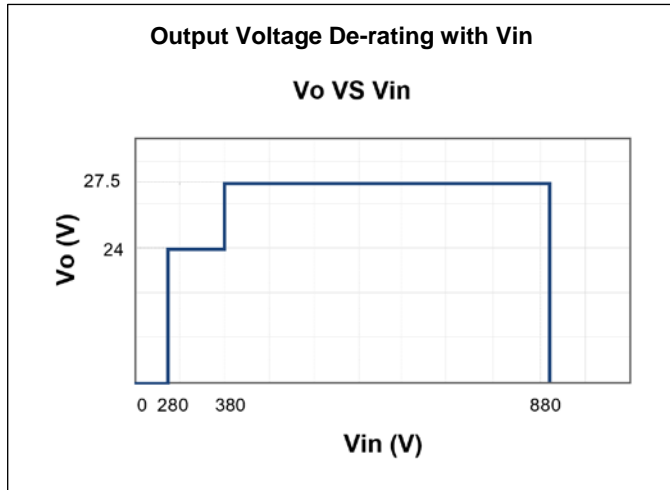

Mechanical Specification

Dimension and Outline Drawing

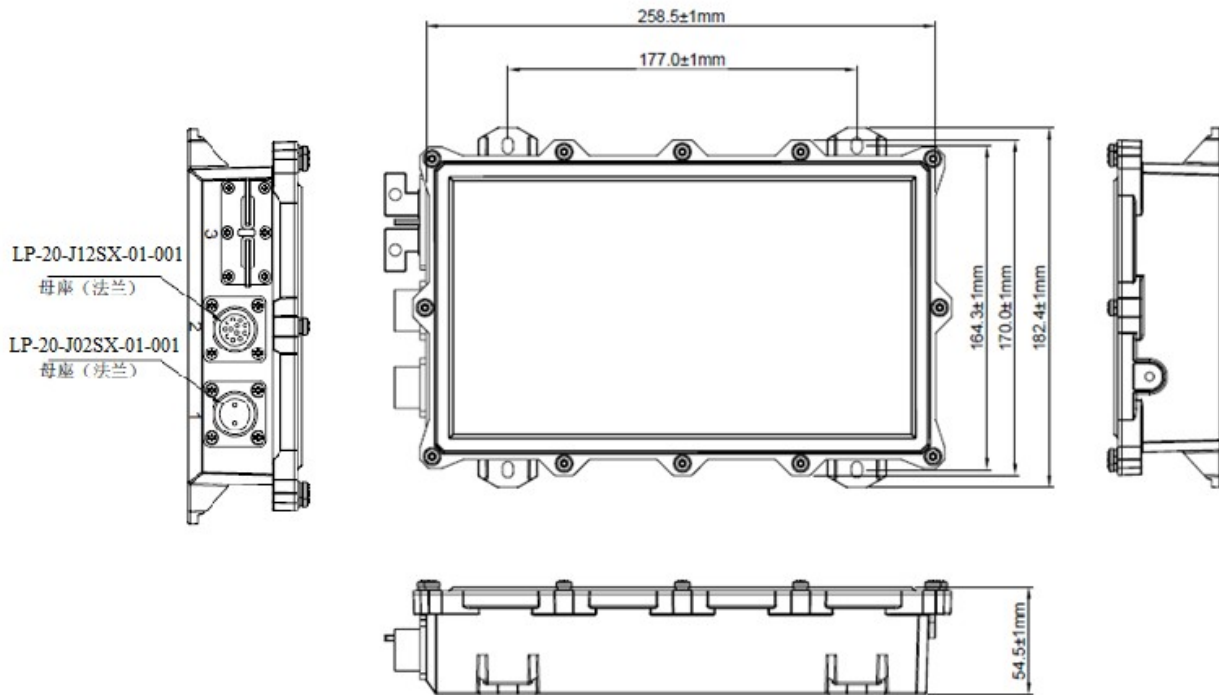

Aux power & Signal Ports

Function	Pin No.	Signal	Note
AUX In*	8	24V	Aux. Power Input
	6	24V_GND	Aux. Power Input
CAN	3	CAN-H	CAN H signal / CAN H
	5	CAN-L	CAN L signal / CAN L
CONTROL	10	#PSON	On/off control: - power on: LOW resistance (ref 1k ohm) to AUXin GND - power off: open or >1Meg ohm to AUXin GND

Communication signals can be customized if necessary.

Connector	Model	Manufacturer
Input Connector	LP-20-J02SX-01-001	Cnlinko
Signal Connector	LP-20-J12SX-01-001	Cnlinko

*The instructions will be shipped with the goods.

Package

Carton	LxWxH =420mmx335mmx165mm
EPE	2pcs/carton
Shield Board	2pcs/carton
DC/DC power supply	4pcs/carton
Net weight	3.85kg/pcs
Gross weight	16kg/carton

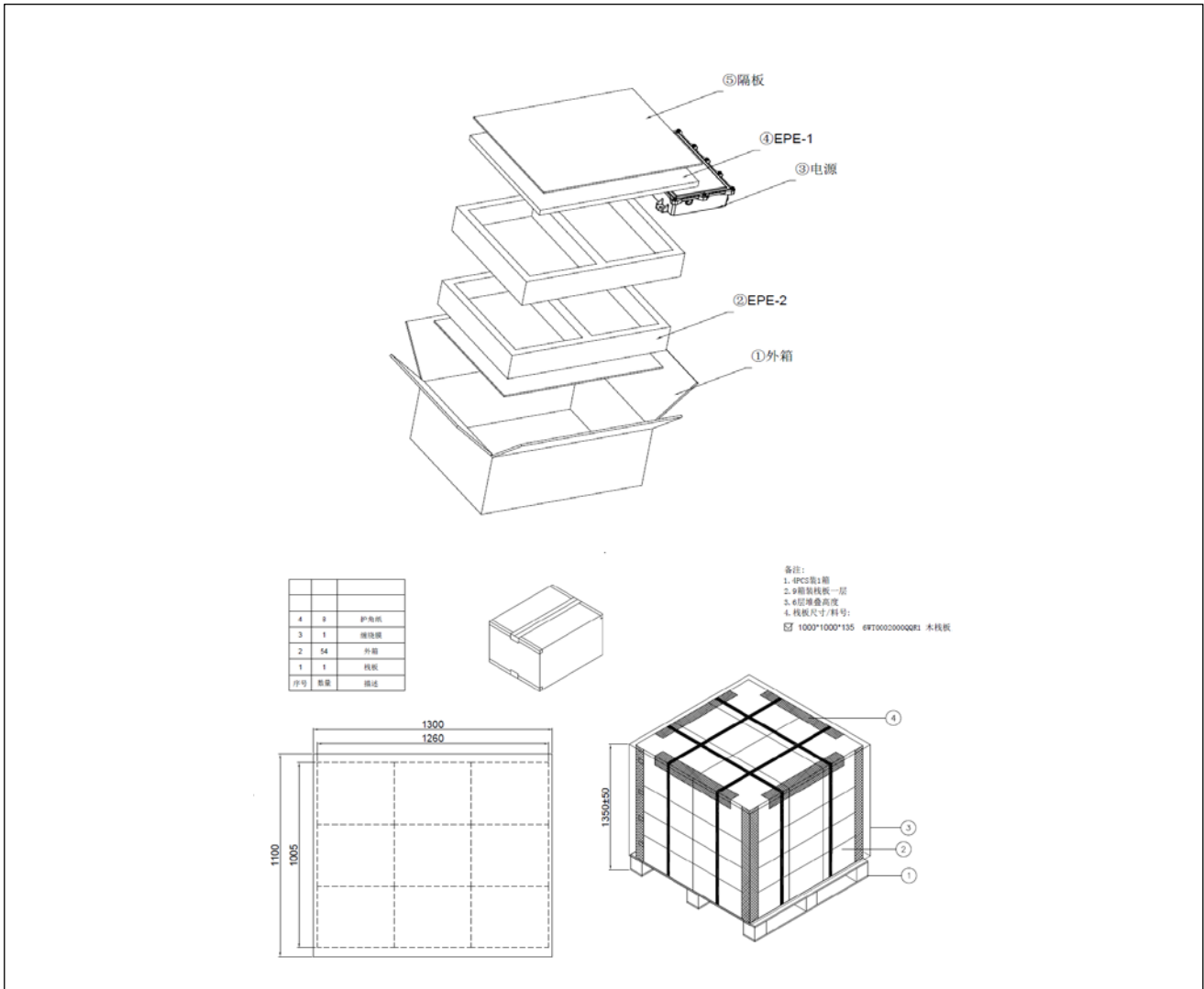

Revision History

Change Date	Rev.	Description of Change		
		Section	From	To
2023.2.13	V0.1	First released.		
2023.6.29	V1.0	Protection functions	Removed restarting in 15s after fault shutdown	
2023.7.21	V1.2	Output under-voltage protection	Modified output under-voltage point from $\leq 5V$ to $\leq 20V$	