

MATERIALS

HOUSING:

ALUMINUM 6061-T6, NICKEL PLATE (500 MICROINCHES MINIMUM) PER SAE-AMS-2404

INSULATOR:

LIQUID CRYSTAL POLYMER (LCP) PER ASTM D5138

CONTACT:

COPPER ALLOY PER MIL-DTL-83513, GOLD PLATED PER ASTM B488, (HARD GOLD) TYPE II CODE C CLASS 1.27

WIRE:

NEMA HP3 TYPE E, COLOR CODED IAW MIL-STD-681, SYSTEM 1, USING TEN SOLID REPEATING COLORS

INTERFACIAL SEAL:

SILICONE RUBBER PER A-A-59588

HARDWARE:

AVAILABLE UPON REQUEST

SOCKET #	COLOR
1, 11, 21, 31	BLACK
2, 12, 22	BROWN
3, 13, 23	RED
4, 14, 24	ORANGE
5, 15, 25	YELLOW
6, 16, 26	GREEN
7, 17, 27	BLUE
8, 18, 28	VIOLET
9, 19, 29	GRAY
10, 20, 30	WHITE

INTERNAL USE ONLY
USE MFG LOADING
PROCEDURE MMDS-031

PART NO.	A99308-031	REV	ECO	DATE	APP
		A	103556	06-20-17	TLM

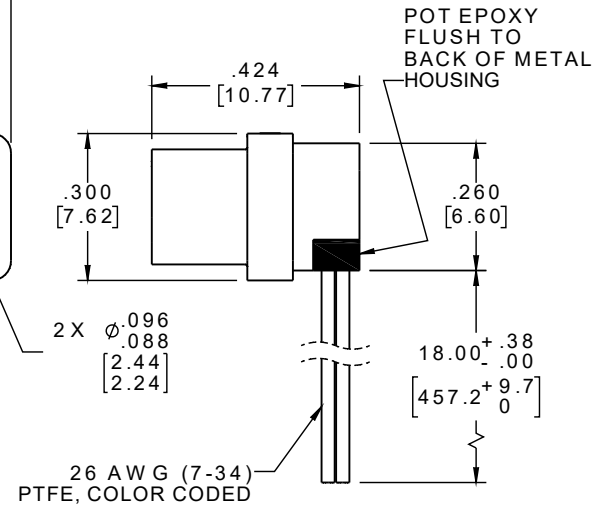
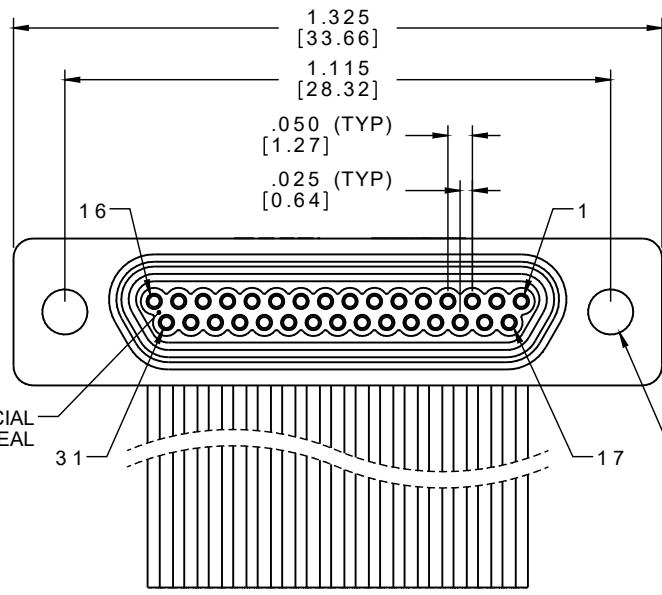
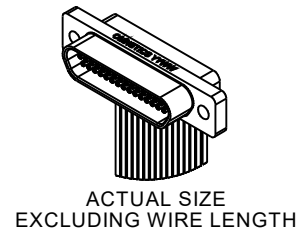
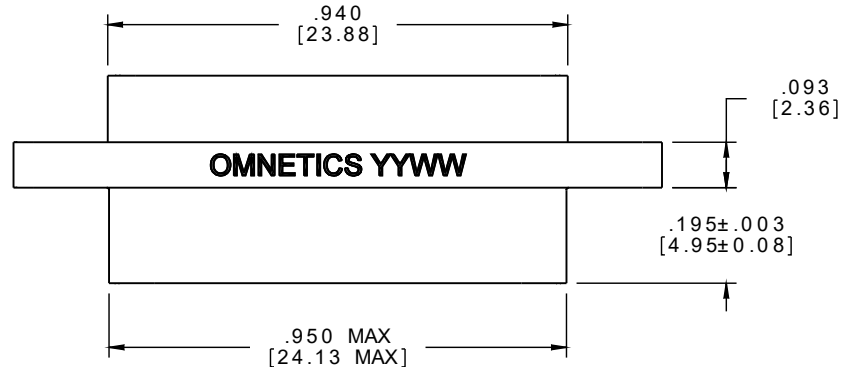

NOTE:

DIMENSIONS IN [] ARE IN MILLIMETERS UNLESS OTHERWISE NOTED AND ARE FOR REFERENCE ONLY

THIRD ANGLE UNLESS OTHERWISE NOTED DIMENSIONS IN INCHES 2 PL DEC ± .01 3 PL DEC ± .005 4 PL DEC ± .0005 ANGLES ± 1°	THIRD ANGLE -TOLERANCES- UNLESS OTHERWISE NOTED DIMENSIONS IN INCHES	THIS DRAWING CONTAINS CONFIDENTIAL AND PROPRIETARY INFORMATION WHICH IS THE PROPERTY OF OMNETICS CONNECTOR CORP. THIS DOCUMENT MAY NOT, IN WHOLE OR IN PART, BE DUPLICATED, OR DISCLOSED FOR ANY PURPOSE, WITHOUT WRITTEN PERMISSION FROM OMNETICS CONNECTOR CORP.		DATE 01-11-17	TITLE: (31) SOCKET FEMALE MICRO-D CONNECTOR
	DFTM. ERB	DATE			
	CHK'D.	DATE			
	APP'D.	DATE			

OMNETICS
CONNECTOR CORPORATION
 7260 COMMERCE CIRCLE EAST
 MINNEAPOLIS, MN 55432
 WWW.OMNETICS.COM

CAGE CODE 61873	REV
DWG NO. A99308-031	A
SHEET 1 OF 1	
SCALE: 3:1	

