

PART NO.	A79151-001	REV	ECO	DATE	APP
		C	99177	01-02-13	TLM

MATERIALS & FINISHES

- INSULATORS
 - THERMOPLASTIC PER MIL-M-24519
- CONTACT MATERIAL
 - SOCKET - COPPER ALLOY PER MIL-DTL-32139
- CONTACT FINISH
 - GOLD PLATE PER ASTM B488, TYPE II (HARD GOLD), CODE C, CLASS 1.27
- WIRE - STANDARD
 - 32 AWG, 7 STRAND, TYPE ET PER NEMA HP3
- SHELLS
 - BRASS ALLOY 360
- SHELL FINISH
 - ELECTROLESS NICKEL PER SAE-AMS-2404

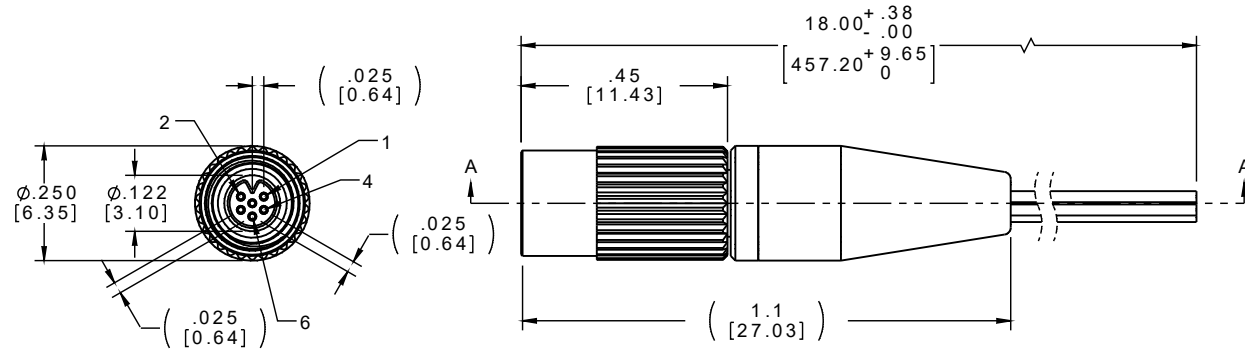

SOCKET #	COLOR
1	BLACK
2	BROWN
3	RED
4	ORANGE
5	YELLOW
6	GREEN

INTERNAL USE ONLY
USE MFG LOADING
PROCEDURE NC-6S

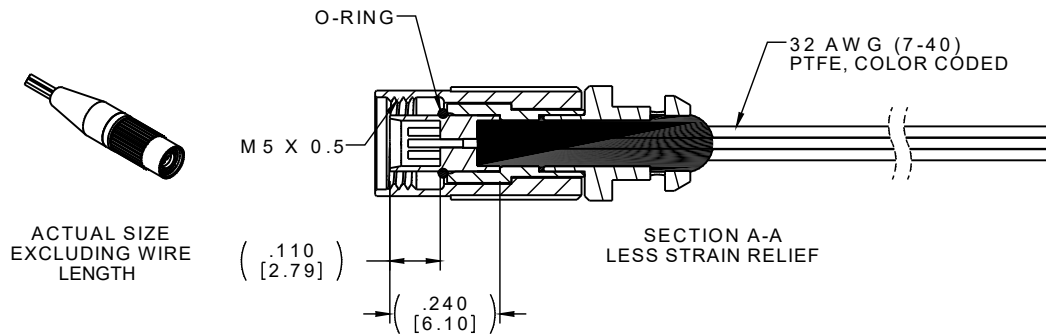

NOTE:

DIMENSIONS IN [] ARE IN MILLIMETERS UNLESS OTHERWISE NOTED AND ARE FOR REFERENCE ONLY

MINI SIZES	THIRD ANGLE
	-TOLERANCES- UNLESS OTHERWISE NOTED
	DIMENSIONS IN INCHES
	2 P L D E C ± .01 3 P L D E C ± .005 4 P L D E C ± .0005 ANGLES ± 1°

THIS DRAWING CONTAINS CONFIDENTIAL AND PROPRIETARY INFORMATION WHICH IS THE PROPERTY OF OMNETICS CONNECTOR CORP. THIS DOCUMENT MAY NOT, IN WHOLE OR IN PART, BE DUPLICATED, OR DISCLOSED FOR ANY PURPOSE, WITHOUT WRITTEN PERMISSION FROM OMNETICS CONNECTOR CORP.

DFTM. JPF	DATE
03-23-09	
CHK'D.	DATE
APP'D.	DATE

TITLE:
(6) SOCKET
CIRCULAR CONNECTOR
W/ METAL SHELL

OMNETICS
CONNECTOR CORPORATION
7260 COMMERCE CIRCLE EAST
MINNEAPOLIS, MN 55432
WWW.OMNETICS.COM

CAGE CODE 61873
DWG NO. A79151-001
SHEET 1 OF 1
SCALE: 3:1
REV C