

TKV-012-17-ROUND-DGI-IP65-BP



TKV-012-17-ROUND-DGI-IP65-BACKL-BP



FEATURES

- Vandal resistant numeric keypad
- Recessed version for rear integration
- Robust and durable
- Resistant to dirt, dust and liquid (IP65)
- Optionally available with backlight

SPECIFICATION

Number of keys:	12	Switch travel:	0.6 mm ± 0.1 mm
Key shape:	round	Protection level:	IP65
Key size:	17 mm (diameter)	Impact protection rate:	IK08
Housing type:	backpanel (front plate with mounting holes for rear mounting)	Interface:	matrix (plug connector)
Front plate material:	stainless steel	Operating temperature:	-10 °C to +70 °C
Keyswitch technology:	Digi-Inox (metal dome)	Storage temperature:	-25 °C to +85 °C
Switching cycles:	approx. 3mill. (per key)	Dimensions:	104 x 78 x 9 mm
Operating force:	4.5 N	Weight:	236 g
		Certifications:	CE, RohS, REACH, EMC

Cat. No.	Product Code	Backlight colour
KV21201	TKV-012-17-ROUND-DGI-IP65-BP-MATRIX	----
KV21202	TKV-012-17-ROUND-DGI-IP65-BACKL-BP-MATRIX	white

Other language versions / interfaces / configurations available on request.

Subject to modifications and errors

TECHNICAL DRAWING (in mm)

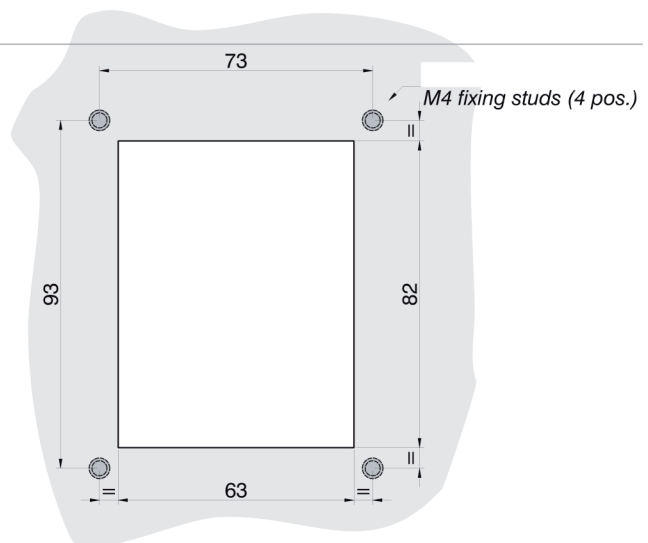
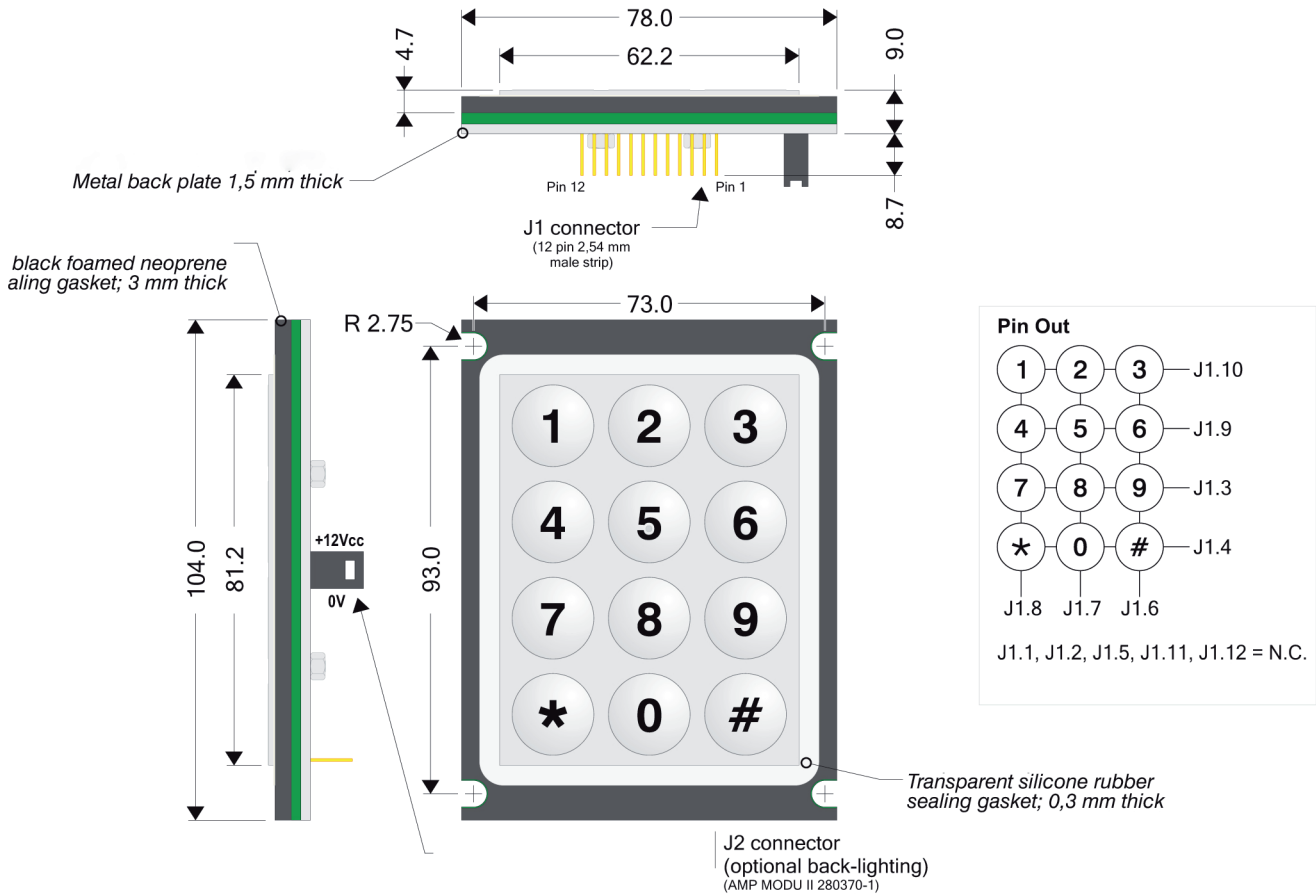

Subject to modifications and errors