



SPECIFICATION SHEET

| | |
|--------------------------------|--|
| SPECIFICATION SHEET NO. | Q0526-SDR433M920S011 |
| DATE | May 26, 2023 |
| REVISION | A0 |
| DESCRIPTION | SMD SAW Resonator L3.0*W3.0*H1.25mm 3030 Type 6 Pads SDR Series 433.92000MHz, 1-Port, Insertion Loss: 2.0 dB Max. Tolerance ±50KHz Operating Temp. Range -40°C ~+85°C, Reflow Profile Condition 260 °C Max. Tape/Reel, 3000pcs/Reel RoHS/RoHS III compliant |
| CUSTOMER | |
| CUSTOMER PART NUMBER | |
| CROSS REF. PART NUMBER | |
| ORIGINAL PART NUMBER | TGS SDR 433.92ME TLF |
| PART CODE | SDR433M920S011 |

| | | | |
|-------------------------|---|--|---|
| VENDOR APPROVE | | | |
| Issued/Checked/Approved |  |  |  |
| DATE: May 26, 2023 | | | |

| | |
|-------------------------|--|
| CUSTOMER APPROVE | |
| | |
| DATE: | |

5/26/2023

SMD SAW RESONATOR 3030 TYPE SDR SERIES

MAIN FEATURE

- SMD SAW Resonator L3.0*W3.0*H1.25mm 3030 Type 6 Pads
- One Port SAW Resonator
- Electrostatic Sensitive Device(ESD)
- Low-loss and Short Lead time
- Cross more competitors part
- RoHS/RoHS III compliant



APPLICATION

- Bluetooth, wireless communication set
- Communication Electronics

RFQ

[Request For Quotation](#)

PART CODE GUIDE

| SDR | 433M920 | S | 011 |
|-----|---------|---|-----|
| 1 | 2 | 3 | 4 |

- 1) SDR: Series Code: SMD SAW Resonator L3.0*W3.0*H1.25mm 3030 Type 6 Pads
- 2) 433M920: Frequency range code for 433.92000MHz
- 3) S: SMD type, Package Tape/Reel,
- 4) 011: Internal code (A~Z or 1~9 or Blank)

SMD SAW RESONATOR 3030 TYPE SDR SERIES

DIMENSION (Unit: mm, Tol.: +-0.15mm)

Image for reference

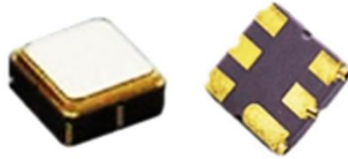

Marking
Standard

SDR series

L3.0*W3.0*H1.25mm

3030 Type

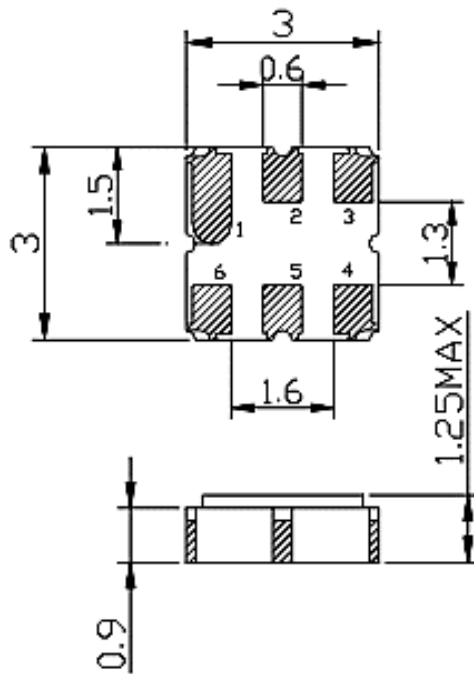

| Pin | Configuration |
|---------|---------------|
| 2 | Input |
| 5 | Output |
| 1,3,4,6 | Ground |

Test Circuit

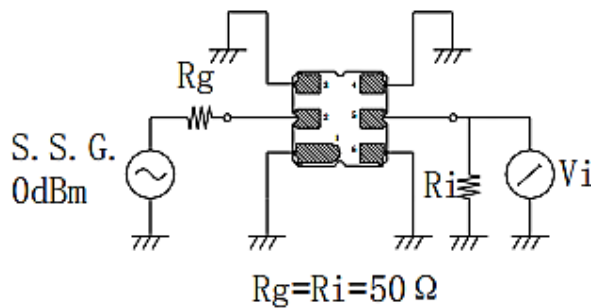

SMD SAW RESONATOR 3030 TYPE SDR SERIES
ELECTRICAL PARAMETERS

| Parameter | Part No. Symbol | Units | Value | | |
|---|-----------------|----------|--|-----------|------|
| | | | Min. | Typical | Max. |
| Original Manufacturer | TGS | | TGS Crystals | | |
| Holder Type | SDR | | SMD SAW Resonator L3.0*W3.0*H1.25mm 3030 Type 6 Pads | | |
| Frequency Range (f0) | 433.92M | MHz | 433.92 | | |
| Frequency Tolerance | E | KHz | | ±50 | |
| Operation Temperature | | °C | -40 | | +85 |
| Storage Temperature | | °C | -55 | | +125 |
| DC Voltage | | V | | ±30 | |
| RF Power Dissipation | | dBm | | 10 | |
| Insertion Loss | | dB | | 1.7 | 2.0 |
| Quality Factor (Q) @Unload | | | | 12366 | |
| Quality Factor (Q) @50 Ω Loaded | | | | 1642 | |
| Turnover Temperature | | °C | 25 | 40 | 55 |
| Frequency Temp. Coefficient | | ppm/°C | | 0.032 | |
| Aging (Absolute Value during the First Year) | | ppm/Year | | ≤±10 | |
| DC Insulation Resistance | | MΩ | 1.0 | | |
| RF Equivalent RLC Model @Motional Resistance | | Ω | | 17.0 | 25.0 |
| RF Equivalent RLC Model @Motional Inductance | | μH | | 69.5 | |
| RF Equivalent RLC Model @Motional Capacitance | | fF | | 1.94 | |
| Static Capacitance | | pF | 2.0 | 2.3 | 2.6 |
| Package | | T | | Tape/Reel | |
| RoHS Status | LF | | RoHS III compliant | | |
| Add Value | | | Blank: N/A | | |
| Internal Control Code | | | Blank: N/A | | |

Note: 1) Test Temperature: 25°C±2°C, Terminating source impedance: 50Ω Terminating load impedance: 50Ω

2) Original Part Number: TGS SDR 433.92ME TLF

5/26/2023

SMD SAW RESONATOR 3030 TYPE SDR SERIES

FREQUENCY RESPONSE

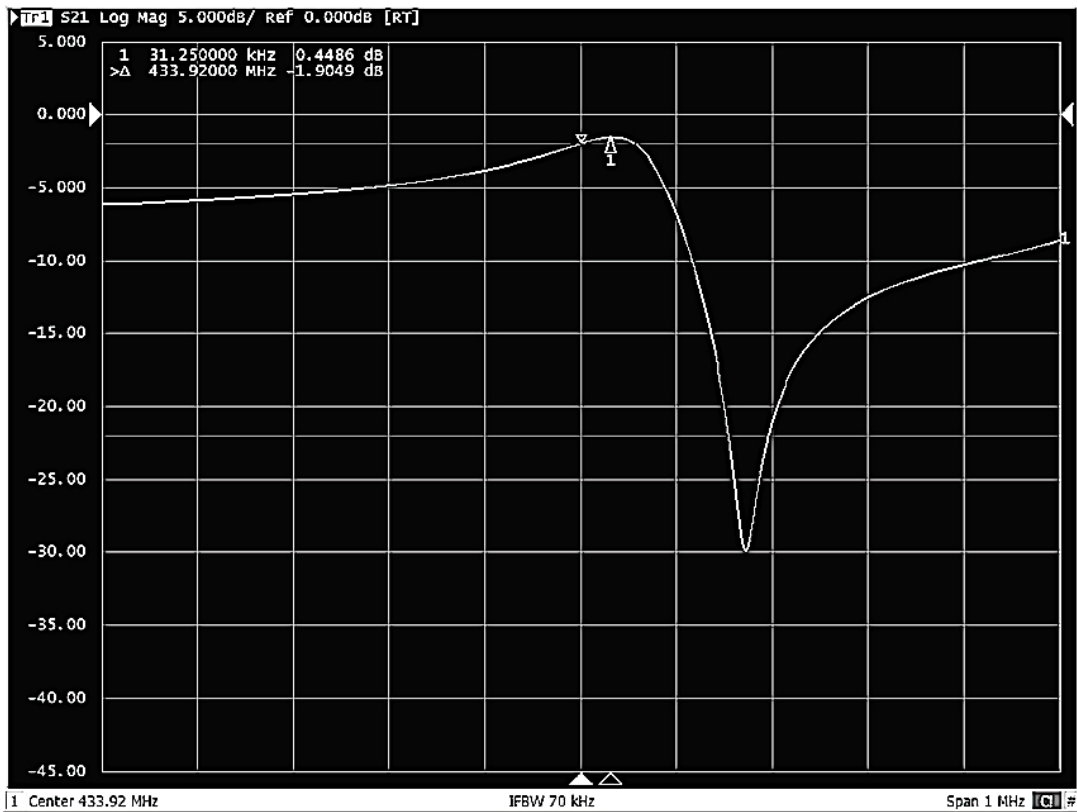

SMD SAW RESONATOR 3030 TYPE SDR SERIES

EQUIVALENT LC MODEL

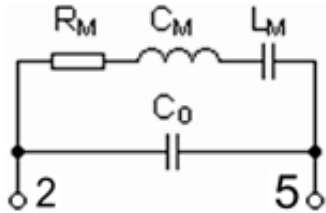

TEMPERATURE CHARACTERISTICS

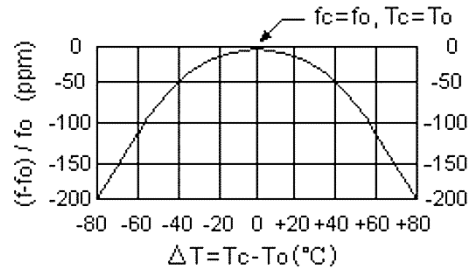

Note: The curve shown above accounts for resonator contribution only and does not include LC component temperature contributions.

PLICTYPCIAL APATION CIRCUITS

Typical Low-power Transmitter Application



Typical Local Oscillator Application



SMD SAW RESONATOR 3030 TYPE SDR SERIES

RELIABILITY

| Test Items | Test Method And Conditions | Requirement |
|-------------------------------------|---|--|
| Temperature Storage | (1) Temperature: 85°C±2°C , Duration: 250h , Recovery time: 2h±0.5h (2) Temperature: -40°C±3°C , Duration: 250h ,Recovery time: 2h±0.5h | It shall remain electrical performance after tests |
| Humidity Test | Conditions: 60°C±2°C , 90~95% RH Duration: 250h | |
| Thermal Shock | Heat cycle conditions: TA=-40°C±3°C, TB=85°C±2°C, t1=t2=30min, Switch time: ≤3min, Cycle time: 100 times, Recovery time: 2h±0.5h. | |
| Vibration Fatigue | Frequency of vibration: 10~55Hz Amplitude:1.5mm Directions: X,Y and Z Duration: 2h | |
| Drop Test | Cycle time: 10 times Height: 1.0m | |
| Solderability | Temperature: 245°C±5°C Duration: 3.0s--5.0s Depth: DIP--2/3 , SMD--1/5 | |
| Resistance to Soldering Heat | (1)Thickness of PCB:1mm , Solder condition: 260°C±5°C , Duration: 10±1s (2)Temperature of Soldering Iron: 350°C±10°C , Duration: 3~4s , Recovery time : 2 ± 0.5h | |

SMD SAW RESONATOR 3030 TYPE SDR SERIES

SUGGESTED REFLOW PROFILE (For Reference Only)

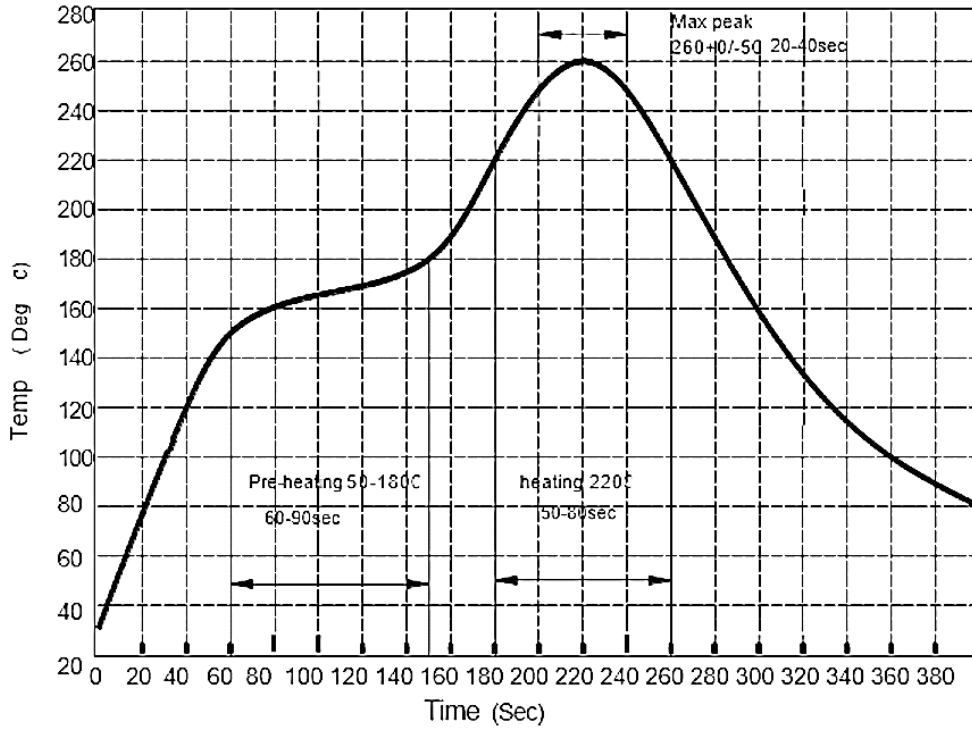

SMD SAW RESONATOR 3030 TYPE SDR SERIES

TAPE DIMENSION (Unit: mm, 3000pcs/Reel)



| Code | Dimension |
|------|-------------|
| W | 12.0+/-0.30 |
| F | 5.50+/-0.10 |
| E | 1.75+/-0.10 |
| P 0 | 4.00+/-0.10 |
| P 1 | 8.00+/-0.10 |
| P 2 | 2.00+/-0.10 |
| D 0 | Ø1.5+/-0.10 |
| D 1 | Ø1.5+/-0.25 |
| t 1 | 0.30+/-0.01 |
| t 2 | 1.90+/-0.05 |
| A | 3.35+/-0.10 |
| B | 3.35+/-0.10 |

REEL DIMENSION (Unit: mm)

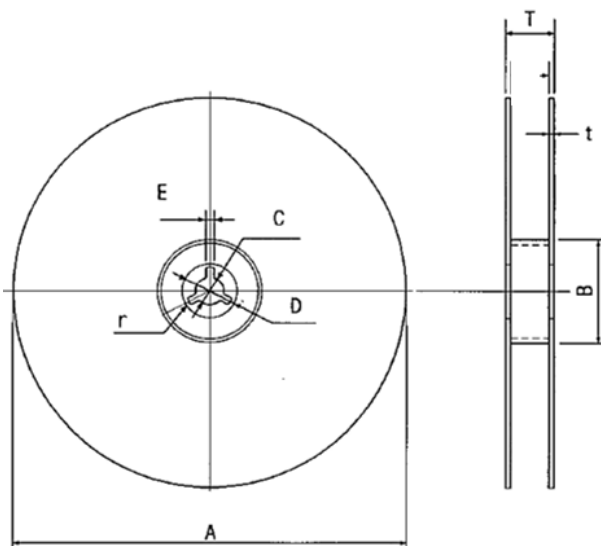

| Code | Dimension |
|------|-------------|
| A | Ø330+/-1.0 |
| B | Ø100+/-0.5 |
| C | Ø13.0+/-0.5 |
| D | Ø21+/-0.8 |
| E | 2.00+/-0.5 |
| T | 13.0+/-0.50 |
| t | 3.00 Max. |
| r | 1.00 Max. |

SMD SAW RESONATOR 3030 TYPE SDR SERIES

CAUTION

1. As a result of the particularity of inner structure of SAW products, it easy to be breakdown by electrostatic, so we should pay attention to ESD protect in the test.
2. Static voltage between signal load and ground may cause deterioration and destruction of the component. Please avoid static voltage.
3. Ultrasonic cleaning may cause deterioration and destruction of the component. Please avoid ultrasonic cleaning.
4. Only leads of component may be soldered. Please avoid soldering another part of component.
5. There is a close relationship between the device's performance and matching network. The specifications of this device are based on the test circuit shown above. L and C values may change depending on board layout. Values shown are intended as a guide only.
6. The temperature of manual welding should not exceed 300 °C.
7. The specifications of this device are based on the test circuit shown above and subject to change or obsolescence without notice.
8. All equipment designs utilizing this product must be approved by the appropriate government agency prior to manufacture or sale.
9. Our liability is only assumed for the Surface Acoustic Wave (SAW) component(s) perse, not for applications, processes and circuits implemented within components or assemblies.
10. For questions on technology, prices and delivery, please contact our sales offices or e-mail: sales@NextGenComponent.com.

DISCLAIMER

NextGen Components, Inc. reserves the right to make changes to the product(s) and or information contained herein without notice. No liability is assumed as a result of their use or application. No rights under any patent accompany the sale of any such product(s) or information

5/26/2023

10