



**SPECIFICATION SHEET**

<b>SPECIFICATION SHEET NO.</b>	Q0528-SBR433M920S022
<b>DATE</b>	May 28, 2023
<b>REVISION</b>	A0
<b>DESCRIPTION</b>	SMD SAW Resonator L3.8*W3.8*H1.50mm 3838 Type 6 Pads SBR Series 433.920000MHz, 1-Port, Insertion Loss: 2.0 dB Max. Tolerance $\pm 75$ KHz Operating Temp. Range $-40^{\circ}\text{C} \sim +85^{\circ}\text{C}$ , Reflow Profile Condition $260^{\circ}\text{C}$ Max. Tape/Reel, 1000pcs/Reel RoHS/RoHS III compliant
<b>CUSTOMER</b>	
<b>CUSTOMER PART NUMBER</b>	
<b>CROSS REF. PART NUMBER</b>	
<b>ORIGINAL PART NUMBER</b>	TGS SBR 433.92MA TLF
<b>PART CODE</b>	SBR433M920S022

<b>VENDOR APPROVE</b>			
Issued/Checked/Approved			
DATE: May 28, 2023			

<b>CUSTOMER APPROVE</b>	
DATE:	

5/28/2023

**SMD SAW RESONATOR 3838 TYPE SBR SERIES**

**MAIN FEATURE**

- SMD SAW Resonator L3.8\*W3.8\*H1.50mm 3838 Type 6 Pads
- Package Code QCC6
- One Port SAW Resonator
- Electrostatic Sensitive Device(ESD)
- Low-loss and Short Lead time
- Cross more competitors part
- RoHS/RoHS III compliant



**APPLICATION**

- Bluetooth, wireless communication set
- Communication Electronics

**RFQ**

[Request For Quotation](#)

**PART CODE GUIDE**

SBR	433M920	S	022
1	2	3	4

- 1) SBR: Series Code, SMD SAW Resonator L3.8\*W3.8\*H1.50mm 3838 Type 6 Pads
- 2) 433M920: Frequency range code for 433.920000MHz
- 3) S: SMD type, Package Tape/Reel,
- 4) 022: Internal code (A~Z or 1~9 or Blank)

**SMD SAW RESONATOR 3838 TYPE SBR SERIES**

**DIMENSION (Unit: mm, Tol.: +-0.15mm)**

Image for reference

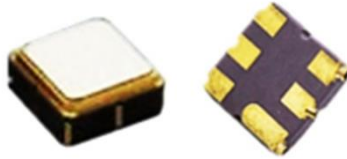

SDR series,  
Package Code QCC6  
L3.8\*W3.8\*H1.5mm  
3838 Type

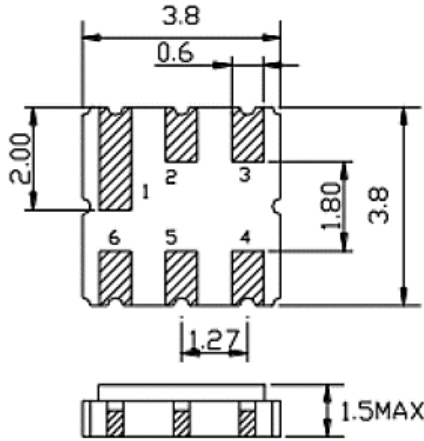

Pin	Configuration
2	Input
5	Output
1,3,4,6	Ground

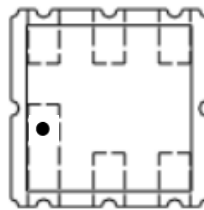

**Marking:**

Standard + ● : Pin 1

**Test Circuit**

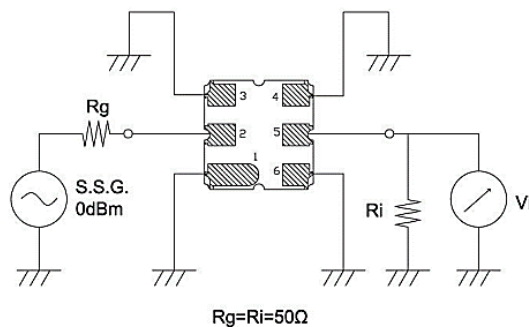

**SMD SAW RESONATOR 3838 TYPE SBR SERIES**
**ELECTRICAL PARAMETERS**

Parameter	Part No. Symbol	Units	Value		
			Min.	Typical	Max.
Original Manufacturer	TGS		TGS Crystals		
Holder Type	SBR		SMD SAW Resonator L3.8*W3.8*H1.5mm 3838 Type 6 Pads		
Frequency Range (f0)	433.92M	MHz	433.92000		
Frequency Tolerance	A	KHz		±75	
Operation Temperature		°C	-40		+85
Storage Temperature		°C	-55		+125
DC Voltage		V		±30	
RF Power Dissipation		dBm		10	
Insertion Loss		dB		1.7	2.0
Quality Factor (Q) @Unload				12366	
Quality Factor (Q) @50 Ω Loaded				1642	
Turnover Temperature		°C	25	40	55
Frequency Temp. Coefficient		ppm/°C		0.032	
Aging (Absolute Value during the First Year)		ppm/Year		≤±10	
DC Insulation Resistance		MΩ	1.0		
RF Equivalent RLC Model @Motional Resistance		Ω		17.0	25
RF Equivalent RLC Model @Motional Inductance		μH		69.5	
RF Equivalent RLC Model @Motional Capacitance		fF		1.94	
Static Capacitance		pF	2.0	2.3	2.6
Package		T		Tape/Reel	
RoHS Status	LF		RoHS III compliant		
Add Value			Blank: N/A		
Internal Control Code			Blank: N/A		

Note: 1) Test Temperature: 25°C±2°C, Terminating source impedance: 50Ω Terminating load impedance: 50Ω

2) Original Part Number: TGS SBR 433.92.0MA TLF

5/28/2023

**SMD SAW RESONATOR 3838 TYPE SBR SERIES**

**FREQUENCY RESPONSE**

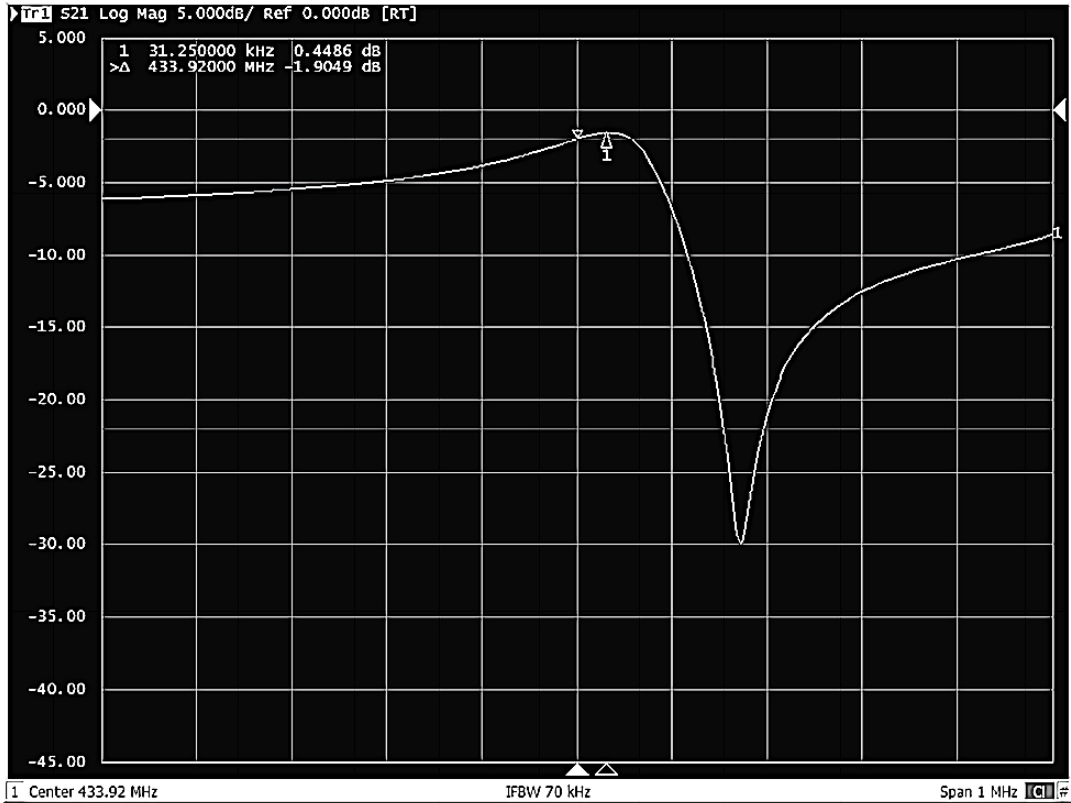

**SMD SAW RESONATOR 3838 TYPE SBR SERIES**

**EQUIVALENT LC MODEL**

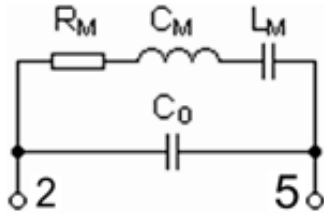

**TEMPERATURE CHARACTERISTICS**

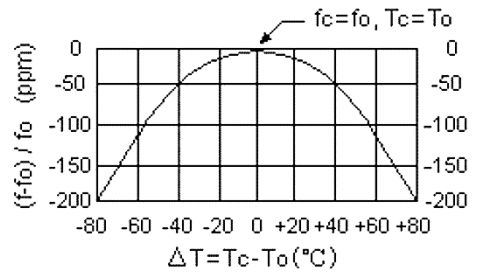

Note: The curve shown above accounts for resonator contribution only and does not include LC component temperature contributions.

**PLICTYPCIAL APATION CIRCUITS**

Typical Low-power Transmitter Application

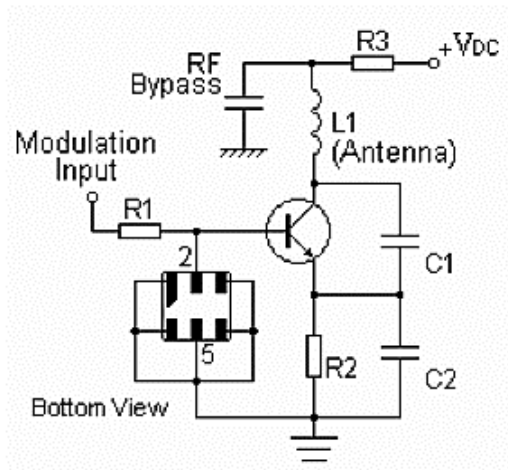

Typical Local Oscillator Application

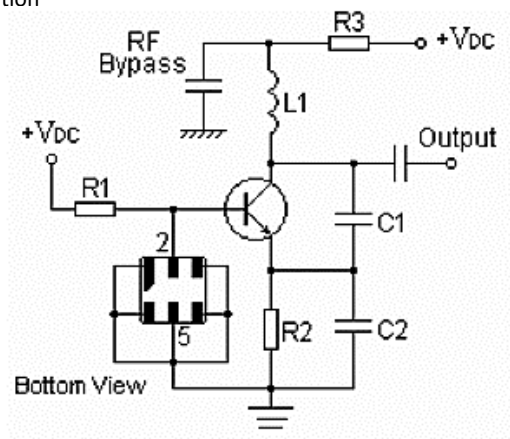

**SMD SAW RESONATOR 3838 TYPE SBR SERIES**

**RELIABILITY**

Test Items	Test Method And Conditions	Requirement
<b>Temperature Storage</b>	(1) Temperature: 85°C±2°C , Duration: 250h , Recovery time: 2h±0.5h (2) Temperature: -40°C±3°C , Duration: 250h ,Recovery time: 2h±0.5h	It shall remain electrical performance after tests
<b>Humidity Test</b>	Conditions: 60°C±2°C , 90~95% RH      Duration: 250h	
<b>Thermal Shock</b>	Heat cycle conditions: TA=-40°C±3°C, TB=85°C±2°C, t1=t2=30min, Switch time: ≤3min, Cycle time: 100 times, Recovery time: 2h±0.5h.	
<b>Vibration Fatigue</b>	Frequency of vibration: 10~55Hz      Amplitude:1.5mm Directions: X,Y and Z      Duration: 2h	
<b>Drop Test</b>	Cycle time: 10 times      Height: 1.0m	
<b>Solderability</b>	Temperature: 245°C±5°C      Duration: 3.0s--5.0s Depth: DIP--2/3 , SMD--1/5	
<b>Resistance to Soldering Heat</b>	(1)Thickness of PCB:1mm , Solder condition: 260°C±5°C , Duration: 10±1s (2)Temperature of Soldering Iron: 350°C±10°C , Duration: 3~4s , Recovery time : 2 ± 0.5h	

**SMD SAW RESONATOR 3838 TYPE SBR SERIES**

**SUGGESTED REFLOW PROFILE (For Reference Only)**





**SMD SAW RESONATOR 3838 TYPE SBR SERIES**

**TAPE DIMENSION (Unit: mm, 1000pcs/Reel)**

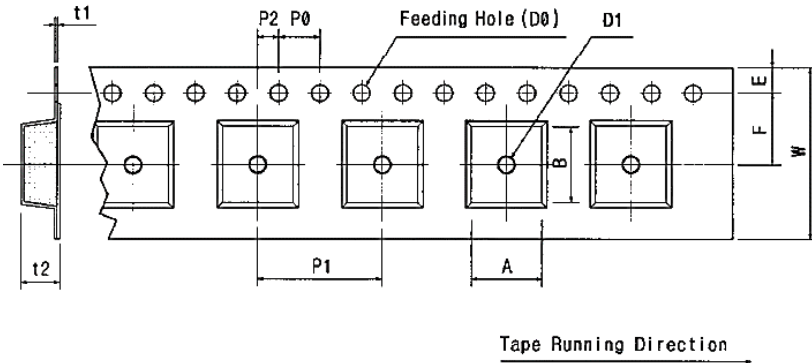

Code	Dimension
W	12.0+/-0.30
F	5.50+/-0.10
E	1.75+/-0.10
P 0	4.00+/-0.10
P 1	8.00+/-0.10
P 2	2.00+/-0.10
D 0	Ø1.5+/-0.10
D 1	Ø1.5+/-0.25
t 1	0.30+/-0.01
t 2	1.90+/-0.05
A	4.00+/-0.10
B	4.00+/-0.10

**REEL DIMENSION (Unit: mm)**

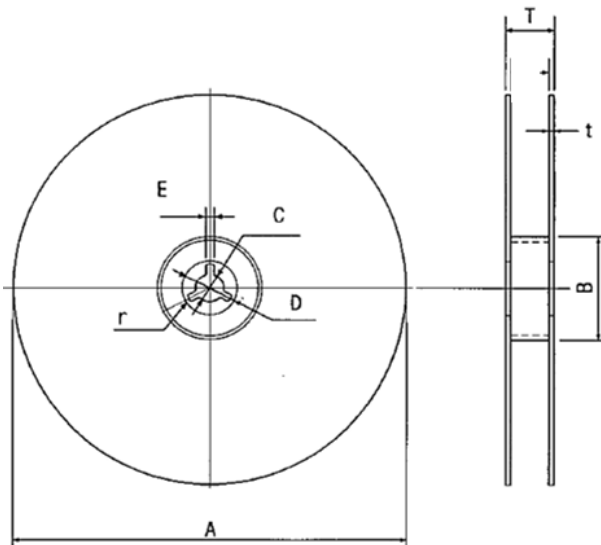

Code	Dimension
A	Ø178.0+/-2.0
B	Ø60.0+/-0.5
C	Ø13.0+/-0.5
D	Ø21+/-0.8
E	2.00+/-0.5
T	15.4+/-1.00
t	0.31 Max.

## SMD SAW RESONATOR 3838 TYPE SBR SERIES

### CAUTION

1. As a result of the particularity of inner structure of SAW products, it easy to be breakdown by electrostatic, so we should pay attention to ESD protect in the test.
2. Static voltage between signal load and ground may cause deterioration and destruction of the component. Please avoid static voltage.
3. Ultrasonic cleaning may cause deterioration and destruction of the component. Please avoid ultrasonic cleaning.
4. Only leads of component may be soldered. Please avoid soldering another part of component.
5. There is a close relationship between the device's performance and matching network. The specifications of this device are based on the test circuit shown above. L and C values may change depending on board layout. Values shown are intended as a guide only.
6. The temperature of manual welding should not exceed 300 °C.
7. The specifications of this device are based on the test circuit shown above and subject to change or obsolescence without notice.
8. All equipment designs utilizing this product must be approved by the appropriate government agency prior to manufacture or sale.
9. Our liability is only assumed for the Surface Acoustic Wave (SAW) component(s) perse, not for applications, processes and circuits implemented within components or assemblies.
10. For questions on technology, prices and delivery, please contact our sales offices or e-mail: [sales@NextGenComponent.com](mailto:sales@NextGenComponent.com).

### DISCLAIMER

NextGen Components, Inc. reserves the right to make changes to the product(s) and or information contained herein without notice. No liability is assumed as a result of their use or application. No rights under any patent accompany the sale of any such product(s) or information

5/28/2023

10