

# 3M™ FOUR-WALL HEADER, 2500 SERIES

.100" X .100" LOW PROFILE, SURFACE MOUNT, STRAIGHT AND RIGHT ANGLE THROUGH-HOLE

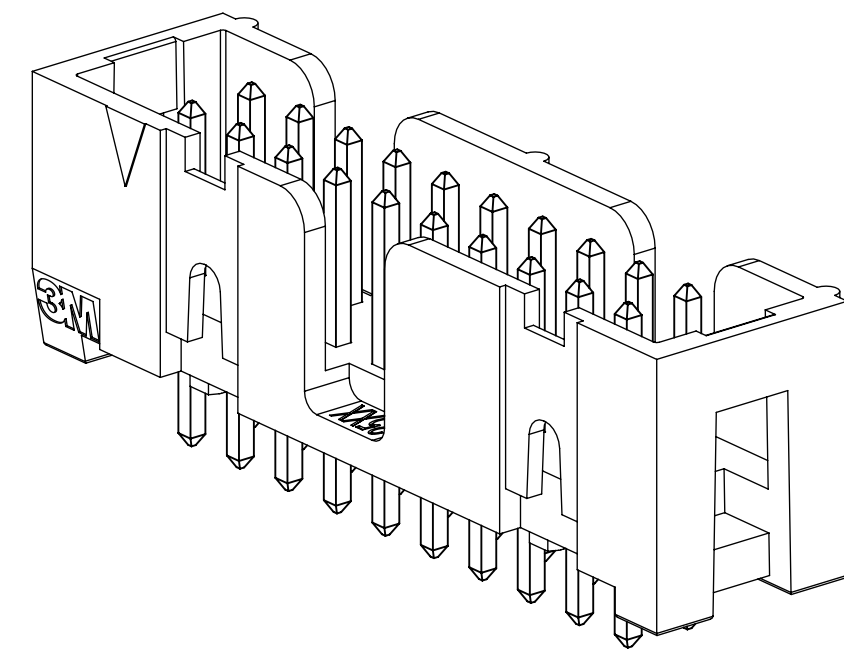

X25XX-60XX  
STRAIGHT VERSION

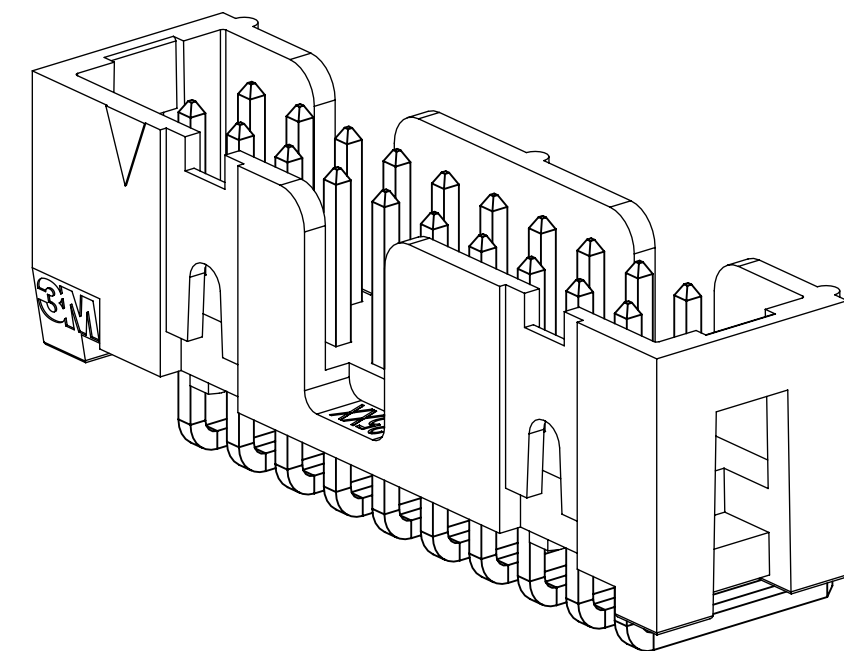

X25XX-50XX  
RIGHT ANGLE VERSION

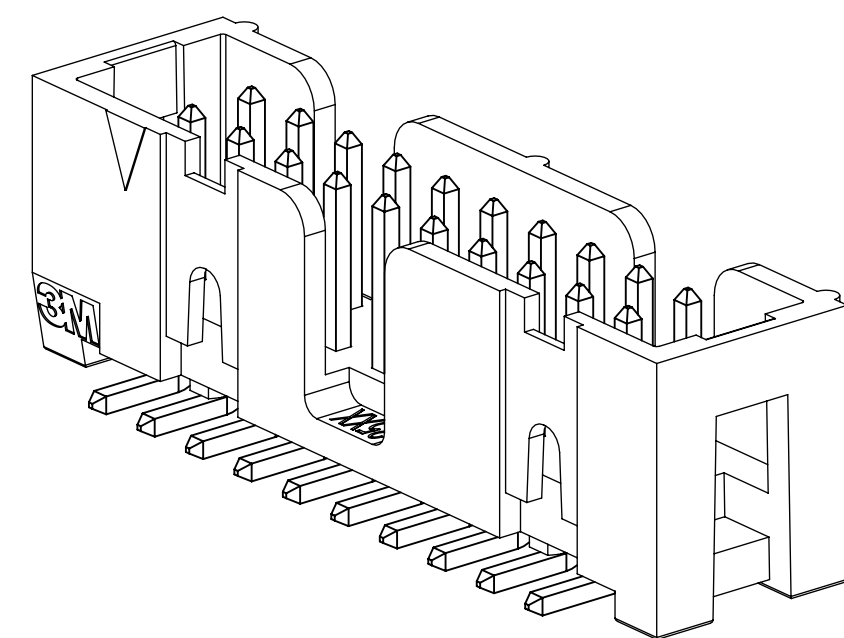

X25XX-6V0C  
SURFACE MOUNT VERSION

- \* LOW PROFILE, SPACE SAVING DESIGN.
- \* CENTER SLOT POLARIZATION PREVENTS MIS-INSERTIONS AND REDUCES INSERTION TIME.
- \* DUAL SLOT POLARIZATION MEANS BROADER COMPATIBILITY WITH COMPETITIVE POLARIZATION DESIGNS (NOT AVAILABLE ON 6, 8 OR 10 POSITIONS).
- \* OPTIONAL RETAINER CLIP FOR LOCKING SOCKETS IN PLACE AND INCREASING CONNECTION RELIABILITY IN VIBRATION-PRONE ENVIRONMENTS.
- \* HIGH TEMPERATURE INSULATOR SUITABLE FOR "NO LEAD" SOLDERING OPERATIONS.
- \* THROUGH HOLE VERSION SUITABLE FOR REFLOW SOLDERING USING "PASTE IN HOLE" TECHNIQUES.
- \* EXPOSED SOLDER TAILS (ON RIGHT ANGLE VERSION) PROVIDE EASE OF CLEANING AND REDUCED REPAIR COST.
- \* STRAIGHT SURFACE MOUNT VERSION AVAILABLE.

## 2 PHYSICAL :

INSULATOR:  
MATERIAL: HIGH TEMPERATURE GLASS FILLED POLYESTER (PCT)  
FLAMMABILITY: UL94V-0  
COLOR: BLACK  
CONTACT:  
MATERIAL: COPPER ALLOY  
PLATING:  
UNDER PLATING: NICKEL UNDERPLATE (SEE ORDERING INFORMATION)  
WIPING AREA: GOLD (SEE ORDERING INFORMATION)  
SOLDER TAILS: MATTE TIN (SEE ORDERING INFORMATION)  
MARKINGS: 3M LOGO, PART IDENTIFICATION NUMBER AND ORIENTATION TRIANGLE

## 2 ELECTRICAL :

CURRENT RATING: 5.00A, 1 CONTACT POWERED  
3.00A, 6 CONTACTS POWERED  
1.75A, ALL CONTACTS POWERED  
RATING CONDITIONS: EIA-364-070 METHOD 2, 30°C MAXIMUM TEMPERATURE RISE, 20% DERATED. REFERENCE APPROPRIATE 3M PRODUCT SPECIFICATION FOR DETAILED CURRENT DERATING CURVES.  
INSULATION RESISTANCE: >1 X 10<sup>9</sup>Ω AT 500 V<sub>DC</sub>  
WITHSTANDING VOLTAGE: 1,000V<sub>RMS</sub> AT SEA LEVEL

## 2 ENVIRONMENTAL :

TEMPERATURE RATING: -55°C TO 105°C  
PROCESS RATING: 260°C, PER J-STD-020C, SINGLE PASS  
MOISTURE SENSITIVITY LEVEL: 1 (PER J-STD-020C)

- NOTES
1. REGULATORY INFORMATION: VISIT 3M.com/regs
  2. IN THE EVENT OF CONFLICT BETWEEN THIS DATA AND THAT CONTAINED IN THE PRODUCT SPECIFICATION, THE PRODUCT SPECIFICATION TAKES PRECEDENT.
  3. NOTCHES A & C WILL ACCOMODATE 3M POLARIZING KEY: N3518.
  4. CONTACT TAILS .0245 [.622] WIRE WITH .0075 [.191] CORNER RADIUS AND .028 [.072] DIAGONAL.
  5. SOLDER STANDOFFS FACILITATE .01 [.3] CLEARANCE ABOVE BOARD FOR REFLOW SOLDERING.

DIMENSIONS: INCHES [ MM ]

DESIGN REFERENCE	NEXT ASSEMBLY	REV	ECO	ISSUE DATE AND DESCRIPTION	DRFT	CHKD
DESIGN CODES		DRFT	DATE	MFG	DATE	
		CHKD	DATE	APPR	DATE	
				R. SCHERER	SEP 05, 2014	
DIVISION	DIVISION CODE	© 3M COPYR [GHT] 2020 This document and the information it contains are 3M property and may not be reproduced or further distributed without 3M permission, or used or disclosed other than for 3M authorized purposes. All rights reserved.				
Interconnect Solutions	EMSD	3M Center St. Paul, MN 55144				
DO NOT SCALE DRAWING	SCALE 4/1	TOLERANCES EXCEPT AS NOTED INCHES: .0 ± .1 .00 ± .01 .000 ± .005 .0000 ± .0002 MILLIMETERS: 0 ± 2 .0 ± .3 .00 ± .13 .000 ± .005 ANGLES:				
THIRD ANGLE PROJECTION	INTERPRET PER ASME Y14.5 - 2018	TITLE HEADER, 4-WALL, LO-PRO, .100 X .100, SMT, STRAIGHT & RA				
MAX SURFACE ROUGHNESS	DTX SURFACES	CAGE NUMBER D 78-5100-0770-7 P				
MARKED ONLY	ANGLES	MODEL 2500 SERIES DET [ ] IS1s [ ] YES [ ] NO [ ] SHT 1 OF 6				

3M ELECTRONIC MATERIALS SOLUTIONS DIVISION  
INTERCONNECT SOLUTIONS  
<http://www.3mconnectors.com>

3M IS A TRADEMARK OF 3M COMPANY.  
FOR TECHNICAL, SALES OR ORDERING  
INFORMATION CALL 800-225-5373

**CAUS**  
UL FILE NO: E68080

P REVISION  
 78-5100-0770-7  
 DRAWING NUMBER  
 B  
 UTC  
 --  
 Time 9/14/2020  
 Drf-set (hrs) 6  
 Standard  
 Imaged: Central

3M™ FOUR-WALL HEADER, 2500 SERIES  
 .100" X .100" LOW PROFILE, SURFACE MOUNT, STRAIGHT AND RIGHT ANGLE THROUGH-HOLE

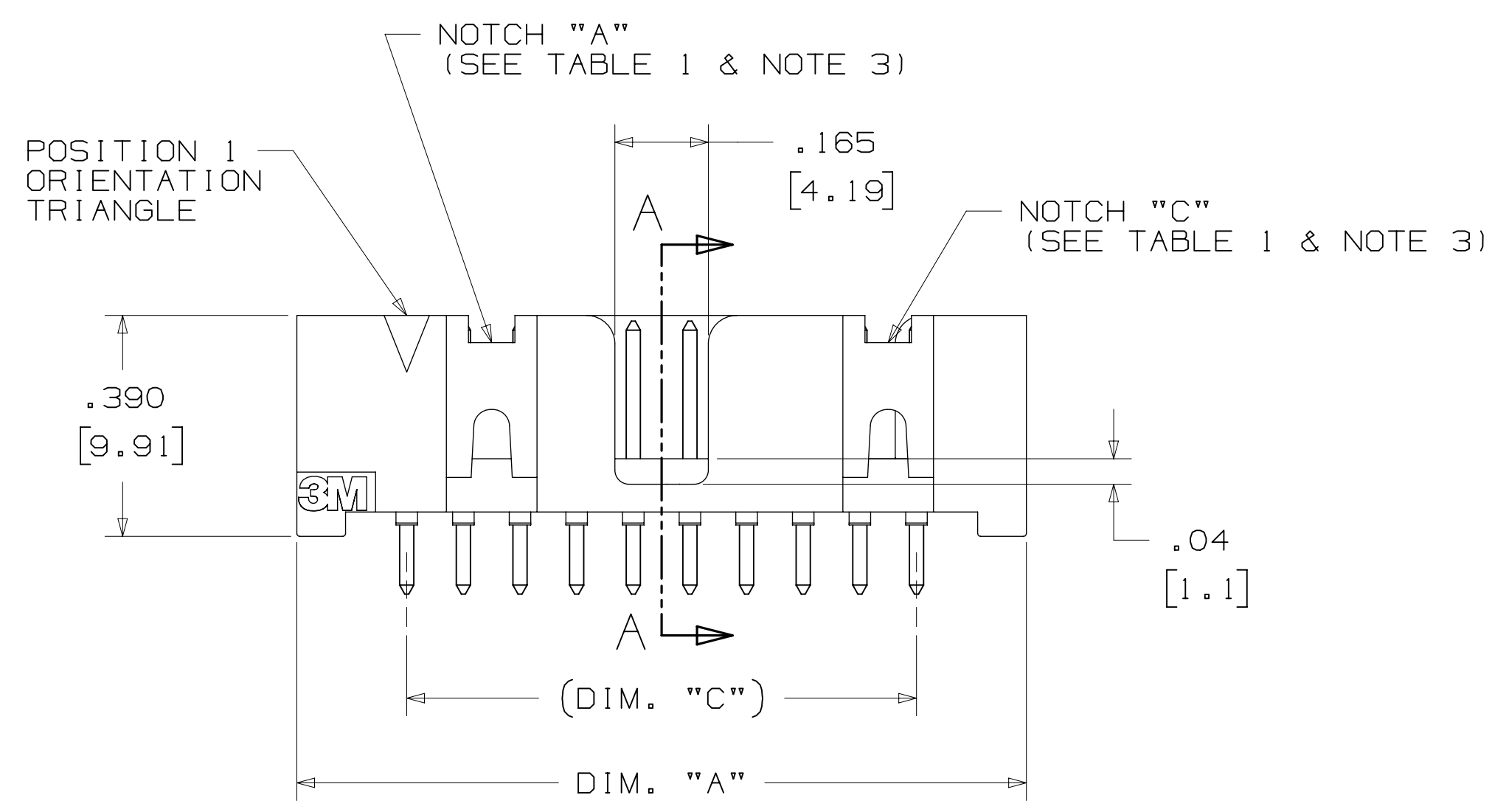
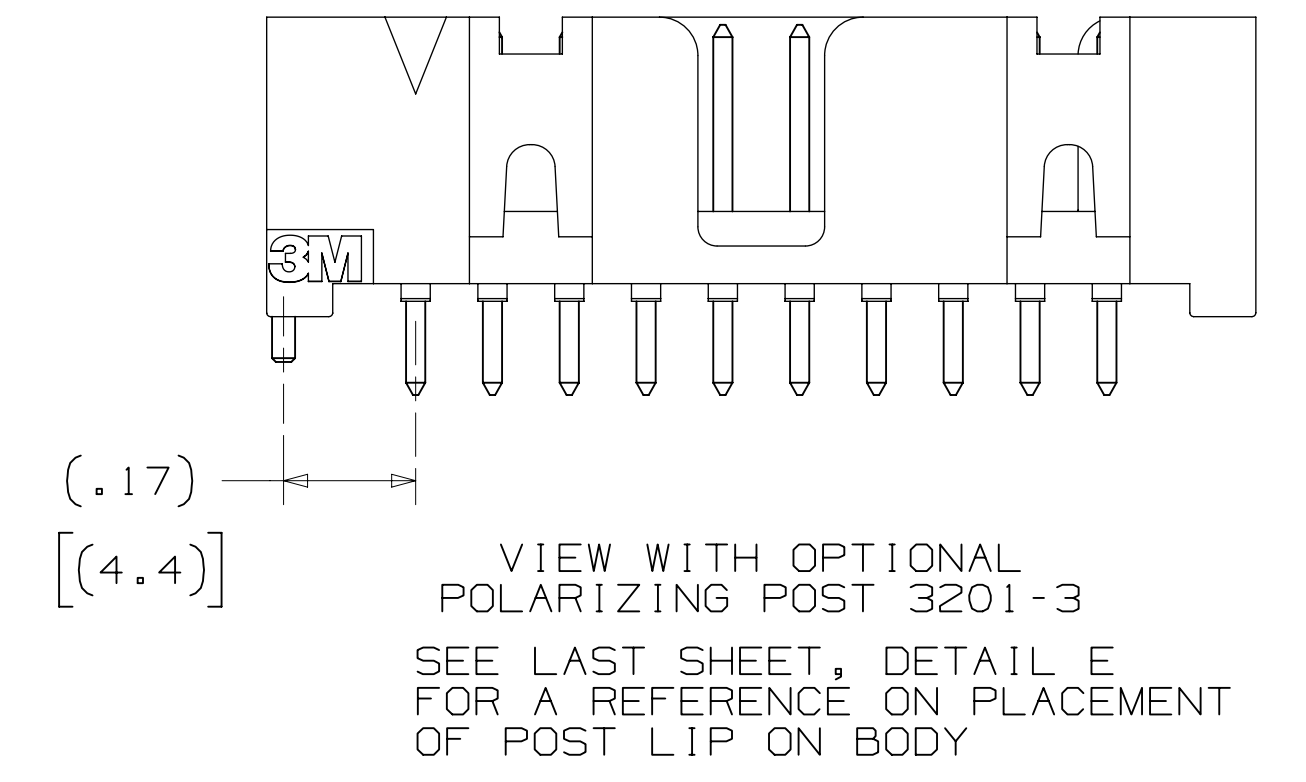
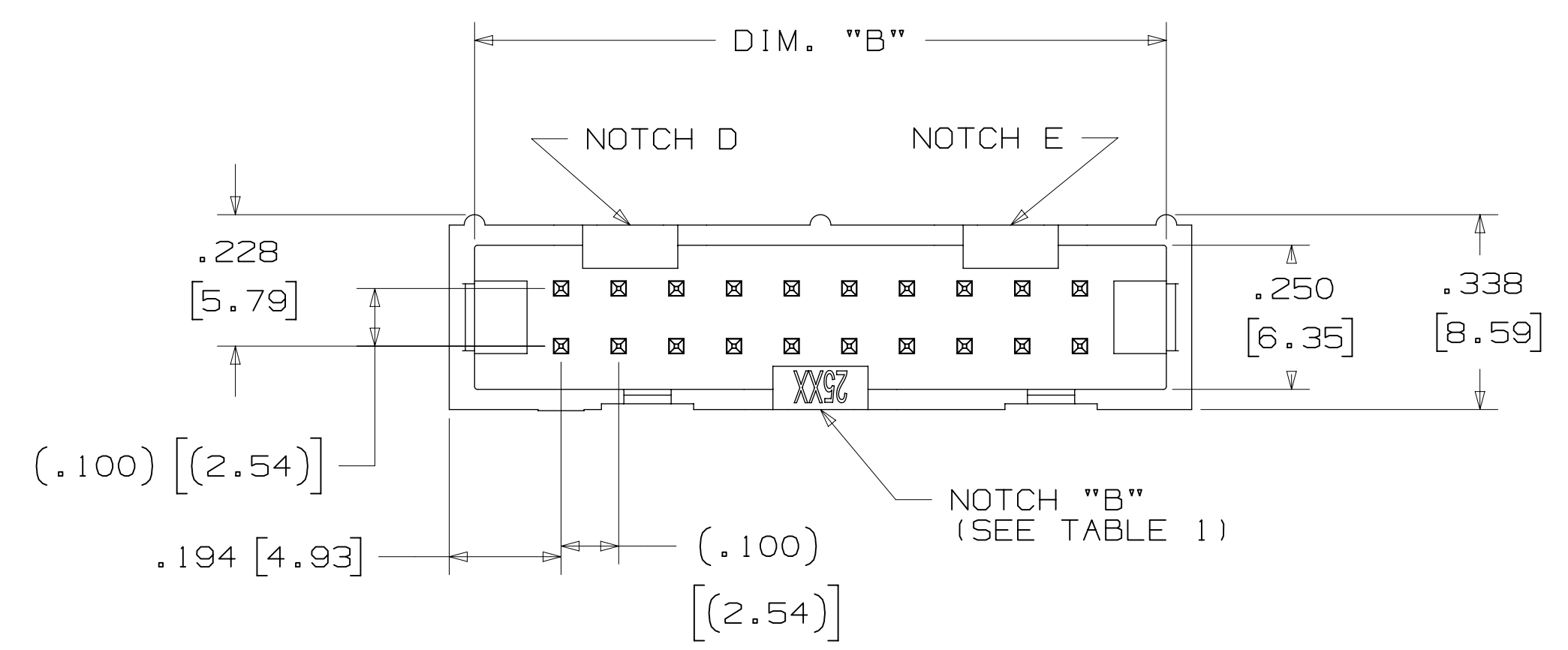
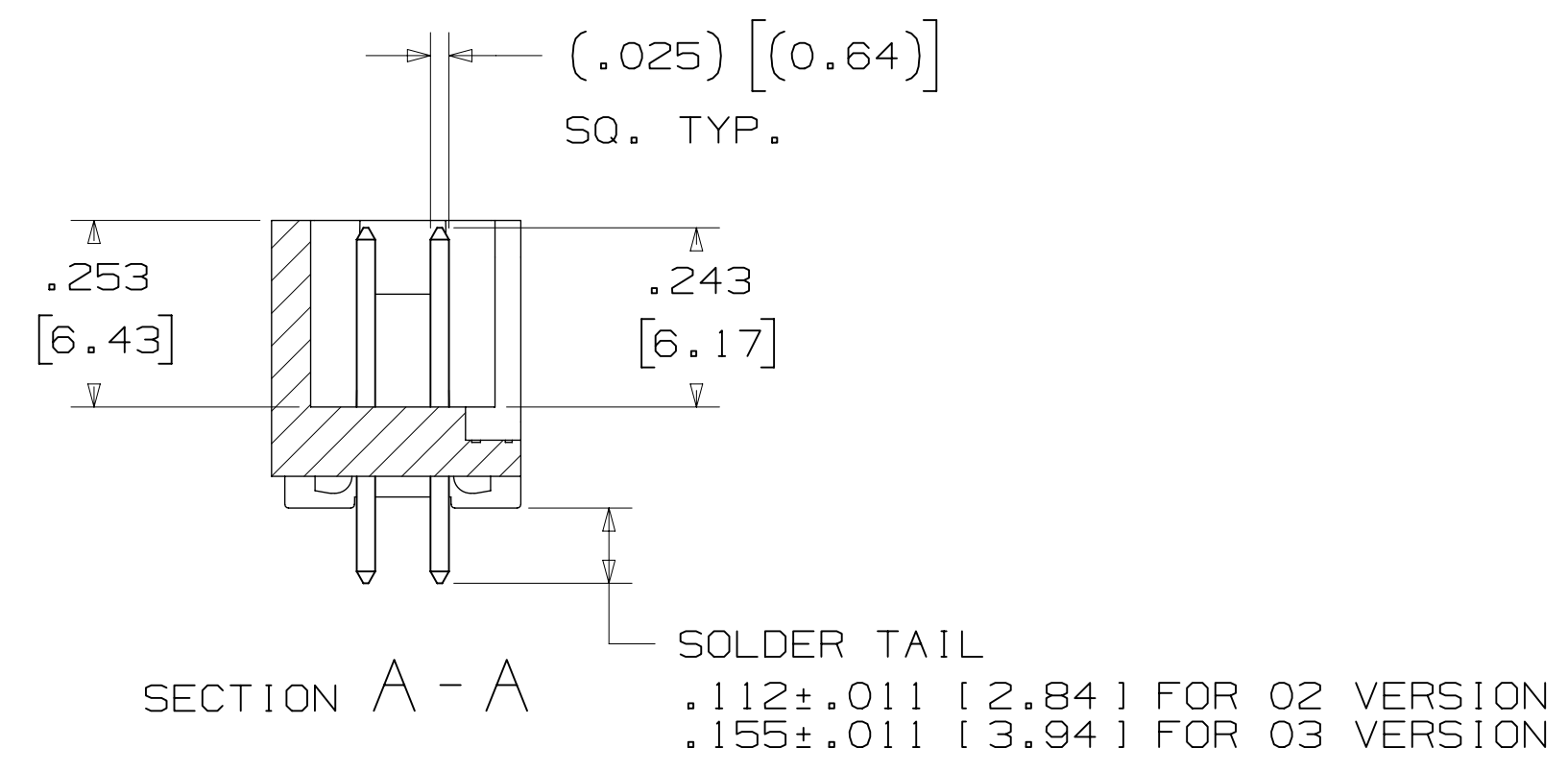
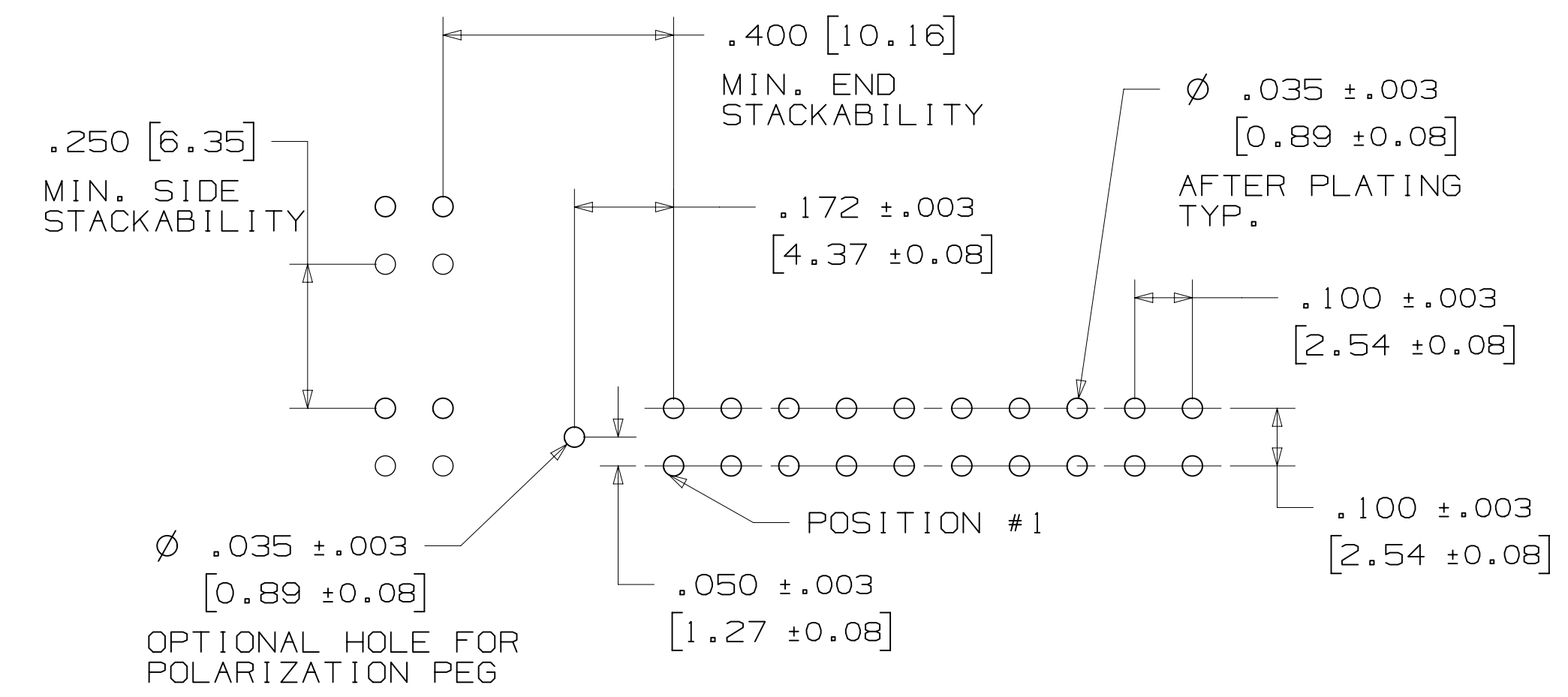

TABLE 1					
PIN QTY.	DIM. "A"	DIM. "B"	DIM. "C"	POLARIZING NOTCHES	PIN QTY.
06	.588 [14.94]	.508 [12.90]	.200 [5.08]	B	06
08	.688 [17.48]	.608 [15.44]	.300 [7.62]	B	08
10	.788 [20.02]	.708 [17.98]	.400 [10.16]	BC	10
14	.988 [25.10]	.908 [23.06]	.600 [15.24]	BCDE	14
16	1.088 [27.64]	1.008 [25.60]	.700 [17.78]	ABCDE	16
20	1.288 [32.72]	1.208 [30.68]	.900 [22.86]	ABCDE	20
24	1.488 [37.80]	1.408 [35.76]	1.100 [27.94]	ABCDE	24
26	1.588 [40.34]	1.508 [38.30]	1.200 [30.48]	ABCDE	26
30	1.788 [45.42]	1.708 [43.38]	1.400 [35.56]	ABCDE	30
34	1.988 [50.50]	1.908 [48.46]	1.600 [40.64]	ABCDE	34
36	2.088 [53.04]	2.008 [51.00]	1.700 [43.18]	ABCDE	36
40	2.288 [58.12]	2.208 [56.08]	1.900 [48.26]	ABCDE	40
50	2.788 [70.82]	2.708 [68.78]	2.400 [60.96]	ABCDE	50
60	3.288 [83.52]	3.208 [81.48]	2.900 [73.66]	ABCDE	60
64	3.488 [88.60]	3.408 [86.56]	3.100 [78.74]	ABCDE	64



ORDERING INFORMATION  
 STRAIGHT VERSION

X25XX-60XX-XX  
 N = RB PLATING REQ'D  
 D = AR PLATING REQ'D (O2 SOLDER TAIL ONLY)  
 PLATING:  
 AR = 10µ" [0.25µm] GOLD AVG.  
 50µ-150µ [1.27µm-3.81µm] NICKEL UNDERPLATE  
 40µ-120µ [1.02µm-3.05µm] MATTE TIN (RIA, E1 & C1 APPLY)  
 RB = 30µ" [0.76µm] GOLD AVG.  
 50µ-150µ [1.27µm-3.81µm] NICKEL UNDERPLATE  
 25µ-200µ [0.63µm-5.08µm] MATTE TIN (RIA, E1 & C1 APPLY)  
 PIN QUANTITY: (SEE TABLE 1)  
 SOLDER TAIL:  
 O2 = FOR .062 [1.57] THICK BOARD  
 O3 = FOR .094 TO .125 [2.39 TO 3.18] THICK BOARD (SOLDER TAIL LENGTH ONLY AVAILABLE ON N25XX-60XX-RB)

RECOMMENDED HOLE PATTERN  
 SHOWN FROM COMPONENT SIDE

DESIGN REFERENCE	NEXT ASSEMBLY	REV	ECO	ISSUE DATE AND DESCRIPTION	DRFT	CHKD
DO NOT SCALE DRAWING	SCALE 4-1	TOLERANCES EXCEPT AS NOTED		INCHES .00 ±.01 .000 ±.005 .0000 ±.0002 MILLIMETERS 0 ±.2 .00 ±.13 .000 ±.005		
THIRD ANGLE PROJECTION	INTERPRET PER ASME Y14.5 - 2018	MAX SURFACE ROUGHNESS		INCHES .000 ±.005 MILLIMETERS .000 ±.005		
DIVISION: Interconnect Solutions SCALE: 4-1 THIRD ANGLE PROJECTION INTERPRET PER ASME Y14.5 - 2018 MAX SURFACE ROUGHNESS: .000 ±.005 (INCHES), .000 ±.005 (MILLIMETERS)		DIVISION CODE: EMSD TOLERANCES EXCEPT AS NOTED INCHES: .00 ±.01, .000 ±.005, .0000 ±.0002 MILLIMETERS: 0 ±.2, .00 ±.13, .000 ±.005		TITLE: HEADER, 4-WALL, LO-PRO, .100 X .100, SMT, STRAIGHT & RA CAGE NUMBER: D78-5100-0770-7 MODEL: 2500 SERIES		
DATE: AUG 11, 2014 DATE: SEP 05, 2014		DATE: AUG 11, 2014 DATE: SEP 05, 2014		DATE: AUG 11, 2014 DATE: SEP 05, 2014		

78-5100-0770-7  
 11/14/2020  
 6 hrs  
 UTC  
 05/14/2020  
 6 hrs  
 UTC  
 05/14/2020  
 6 hrs  
 UTC

# 3M™ FOUR-WALL HEADER, 2500 SERIES

.100" X .100" LOW PROFILE, SURFACE MOUNT, STRAIGHT AND RIGHT ANGLE THROUGH-HOLE

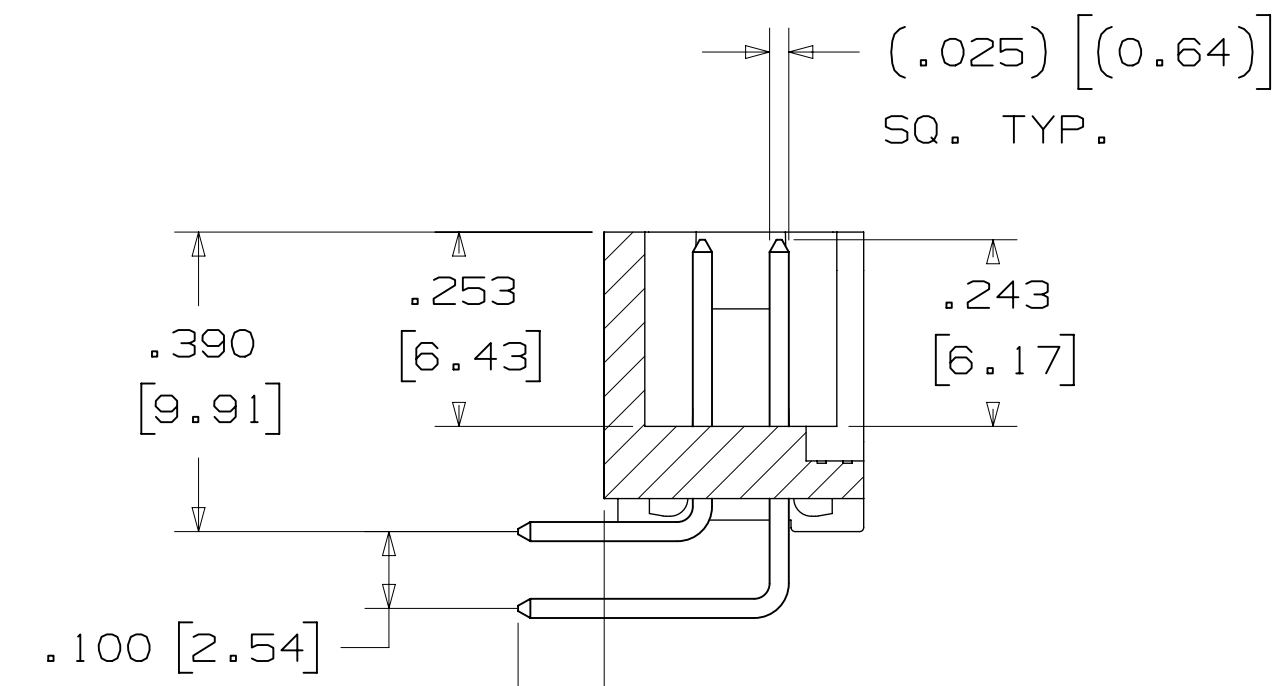

SOLDER TAIL  
 .112±.011 [2.84] FOR 02 VERSION  
 .155±.011 [3.94] FOR 03 VERSION

SECTION B-B

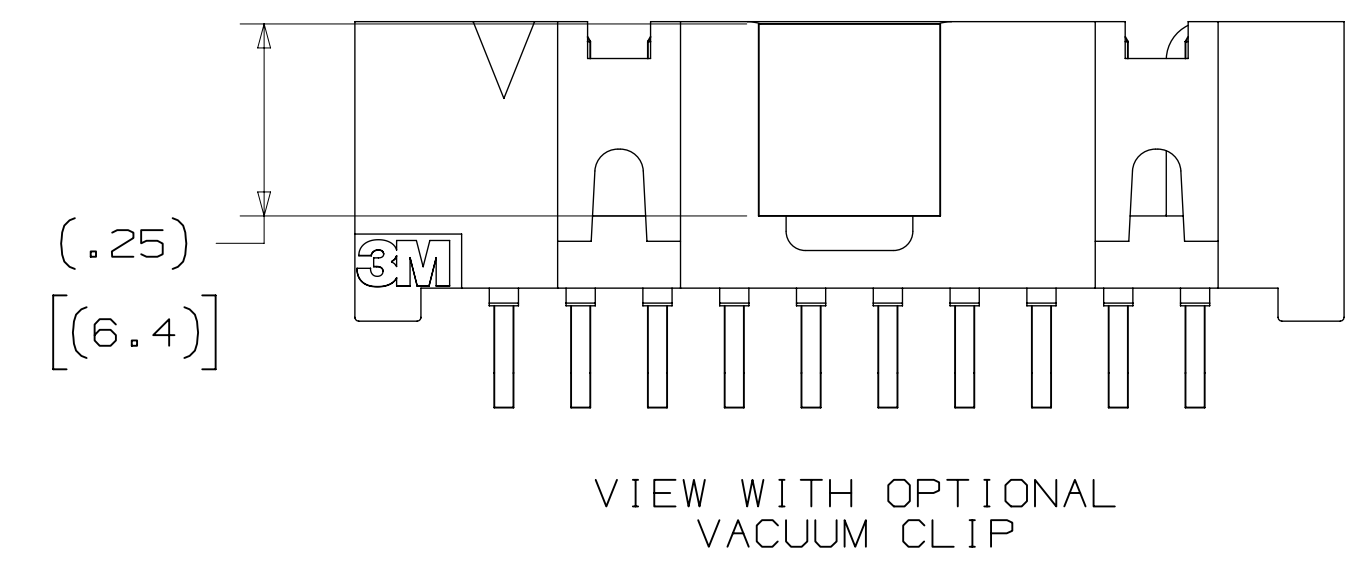
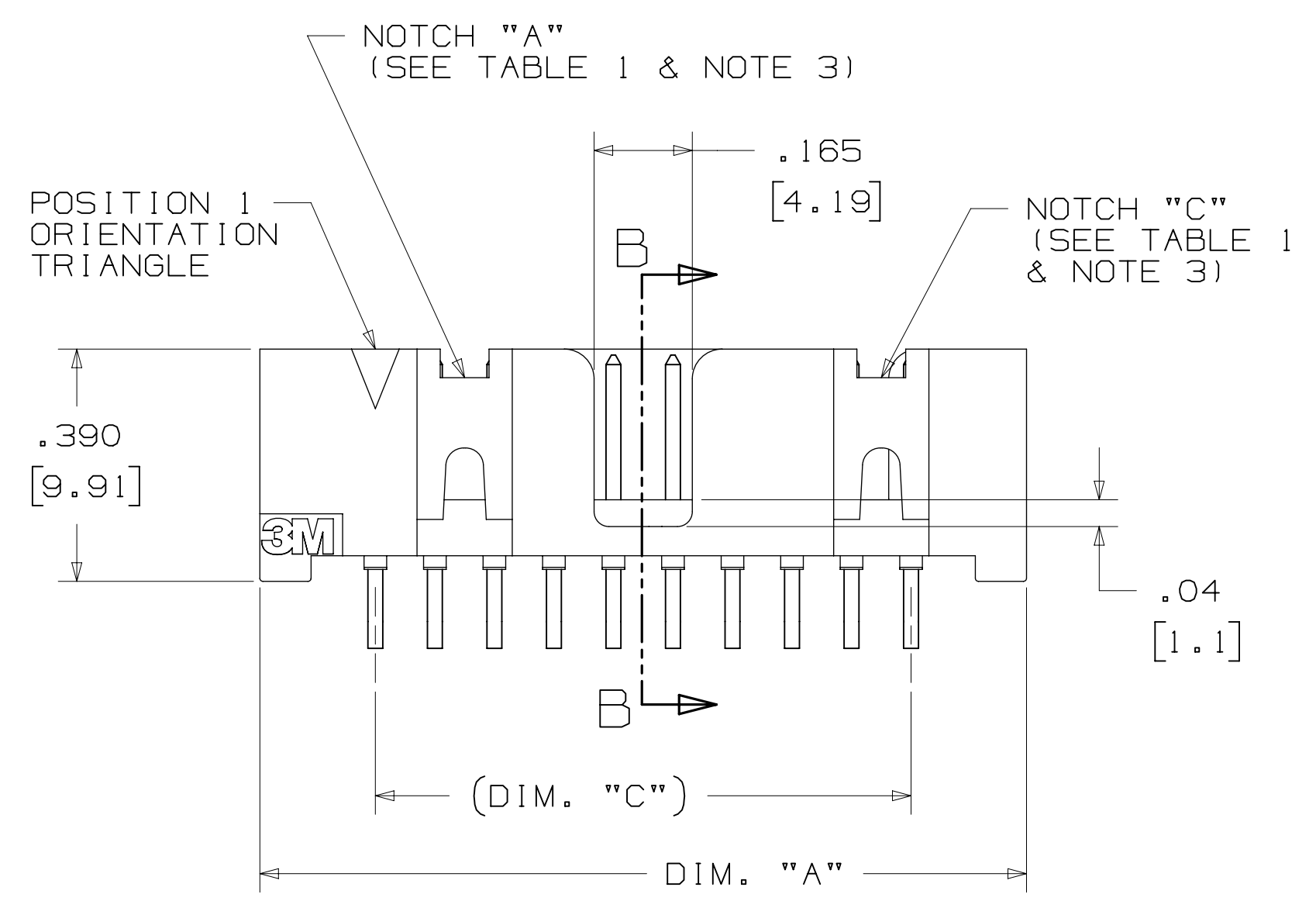
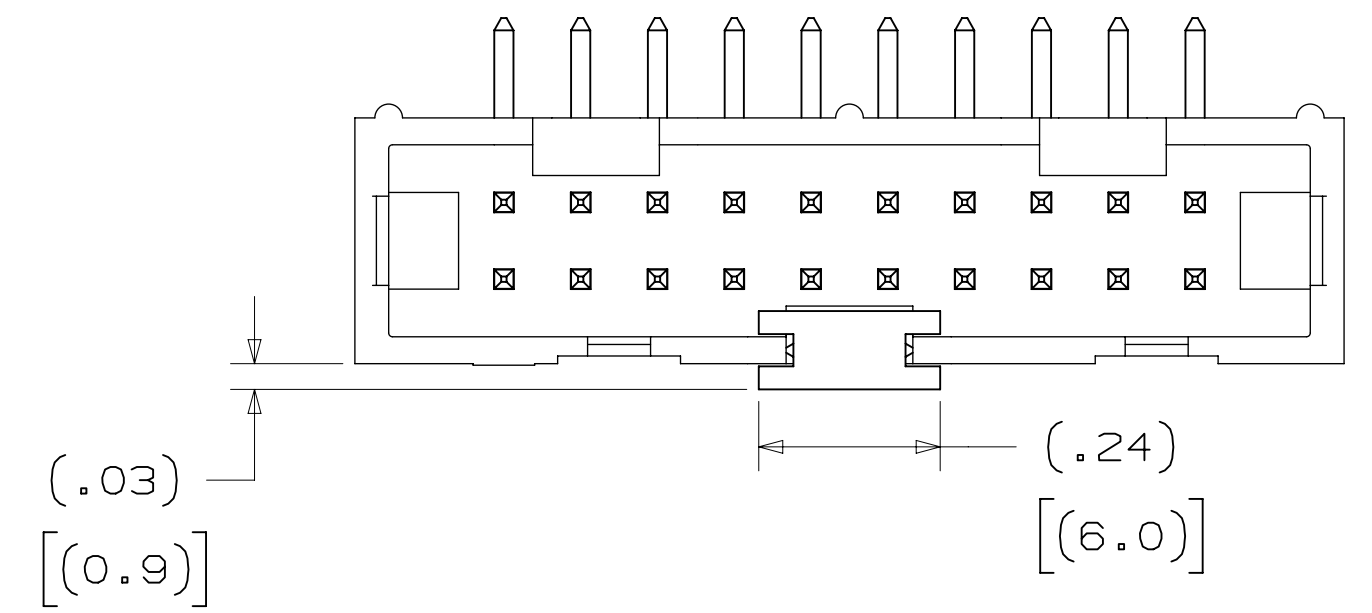
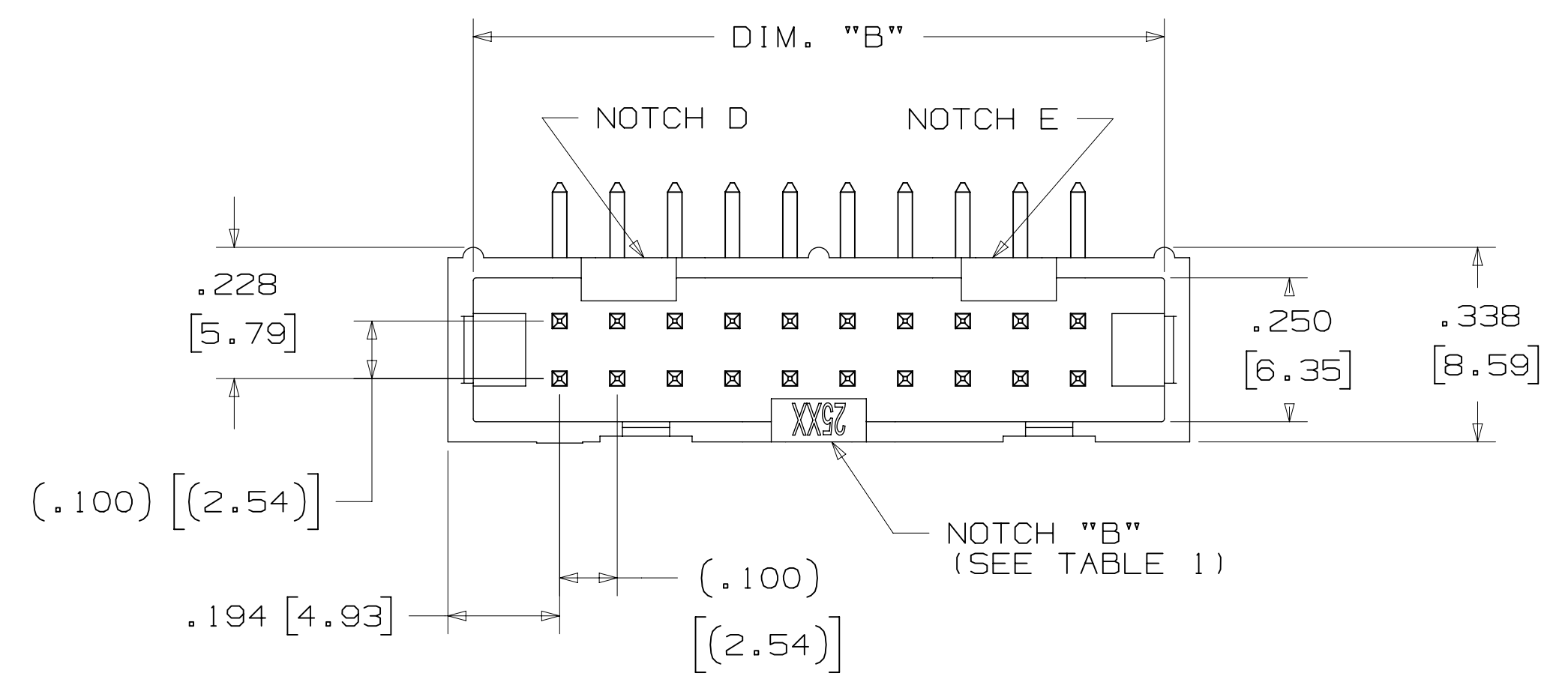
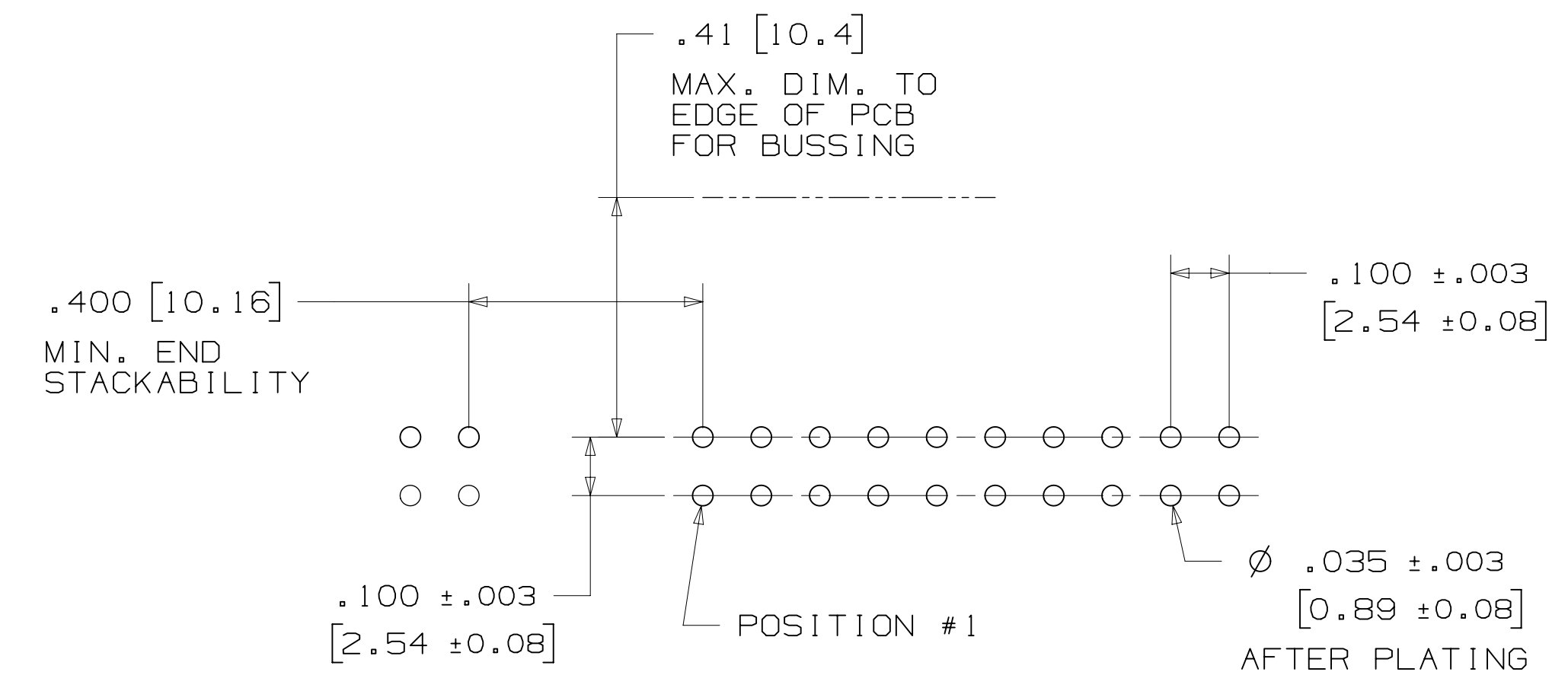

TABLE 1					
PIN QTY.	DIM. "A"	DIM. "B"	DIM. "C"	POLARIZING NOTCHES	PIN QTY.
06	.588 [14.94]	.508 [12.90]	.200 [5.08]	B	06
08	.688 [17.48]	.608 [15.44]	.300 [7.62]	B	08
10	.788 [20.02]	.708 [17.98]	.400 [10.16]	BC	10
14	.988 [25.10]	.908 [23.06]	.600 [15.24]	BCDE	14
16	1.088 [27.64]	1.008 [25.60]	.700 [17.78]	ABCDE	16
20	1.288 [32.72]	1.208 [30.68]	.900 [22.86]	ABCDE	20
24	1.488 [37.80]	1.408 [35.76]	1.100 [27.94]	ABCDE	24
26	1.588 [40.34]	1.508 [38.30]	1.200 [30.48]	ABCDE	26
30	1.788 [45.42]	1.708 [43.38]	1.400 [35.56]	ABCDE	30
34	1.988 [50.50]	1.908 [48.46]	1.600 [40.64]	ABCDE	34
36	2.088 [53.04]	2.008 [51.00]	1.700 [43.18]	ABCDE	36
40	2.288 [58.12]	2.208 [56.08]	1.900 [48.26]	ABCDE	40
50	2.788 [70.82]	2.708 [68.78]	2.400 [60.96]	ABCDE	50
60	3.288 [83.52]	3.208 [81.48]	2.900 [73.66]	ABCDE	60
64	3.488 [88.60]	3.408 [86.56]	3.100 [78.74]	ABCDE	64



## ORDERING INFORMATION RIGHT ANGLE VERSION

X25XX-50XX-XX

N = RB PLATING REQ'D  
 D = AR PLATING REQ'D (02 SOLDER TAIL ONLY)

PIN QUANTITY: (SEE TABLE 1)

SOLDER TAIL:  
 02 = FOR .062 [1.57] THICK BOARD  
 03 = FOR .094 TO .125 [2.39 TO 3.18] THICK BOARD (SOLDER TAIL LENGTH ONLY AVAILABLE ON N25XX-50XX-RB)

PLATING:  
 AR = 10µ [0.25µm] GOLD AVG.  
 50µ-150µ [1.27µm-3.81µm] NICKEL UNDERPLATE  
 40µ-120µ [1.02µm-3.05µm] MATTE TIN (RIA, E1 & C1 APPLY)

RB = 30µ [0.76µm] GOLD AVG.  
 50µ-150µ [1.27µm-3.81µm] NICKEL UNDERPLATE  
 25µ-200µ [0.63µm-5.08µm] MATTE TIN (RIA, E1 & C1 APPLY)

## RECOMMENDED HOLE PATTERN SHOWN FROM COMPONENT SIDE

DESIGN REFERENCE	NEXT ASSEMBLY	REV	ECO	ISSUE DATE AND DESCRIPTION	DRFT	CHKD
		CASTIGLIONE	AUG 11, 2014	MFG	DATE	DATE
DIVISION: Interconnect Solutions		DIVISION CODE: EMSD		© 3M COPYR[IGHT] 2020 This document and the information it contains are 3M property and may not be reproduced or further distributed without 3M permission, or used or disclosed other than for 3M authorized purposes. All rights reserved.		
DO NOT SCALE DRAWING	SCALE: 4/1	TOLERANCES EXCEPT AS NOTED		<b>3M</b> Center St. Paul, MN 55144		
THIRD ANGLE PROJECTION	INTERPRET PER ASME Y14.5 - 2018	INCHES: .00 ±.01 .000 ±.005 .0000 ±.0002 MILLIMETERS: 0 ±.2 .00 ±.13 .000 ±.005		TITLE: HEADER, 4-WALL, LO-PRO, .100 X .100, SMT, STRAIGHT & RA		
MAX SURFACE ROUGHNESS	MARKED ONLY	ANGLE:		CAGE NUMBER: <b>D</b> 78-5100-0770-7 MODEL: 2500 SERIES SHEET: 3 OF 6		

P REVISION  
 178-5100-0770-7  
 DRAWING NUMBER  
 B  
 C  
 D  
 6  
 5  
 4  
 3  
 2  
 1  
 Time 9/14/2020 -- UTC  
 Drt-set (hrs) 6  
 Imaged: Central Standard

# 3M™ FOUR-WALL HEADER, 2500 SERIES

.100" X .100" LOW PROFILE, SURFACE MOUNT, STRAIGHT AND RIGHT ANGLE THROUGH-HOLE

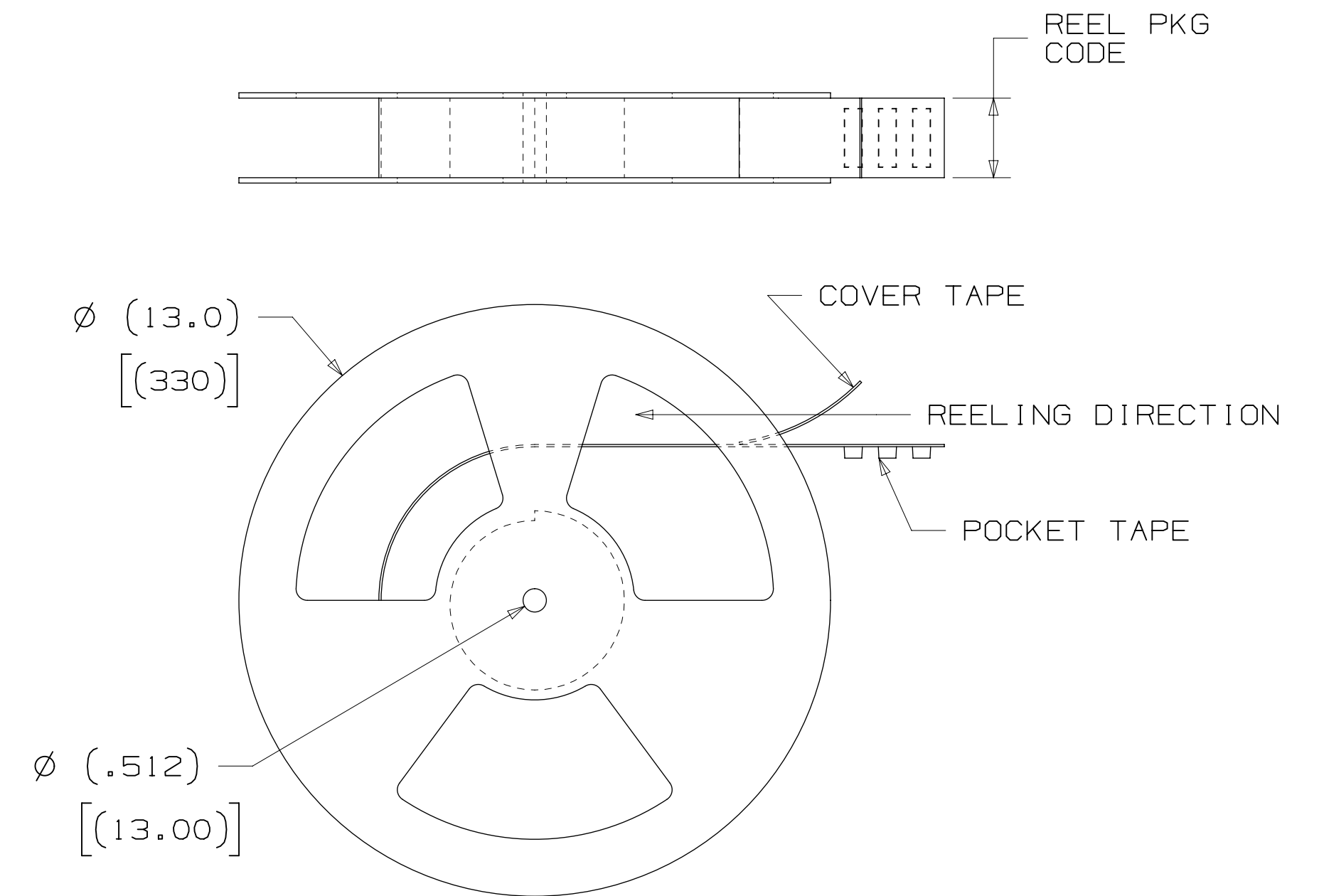
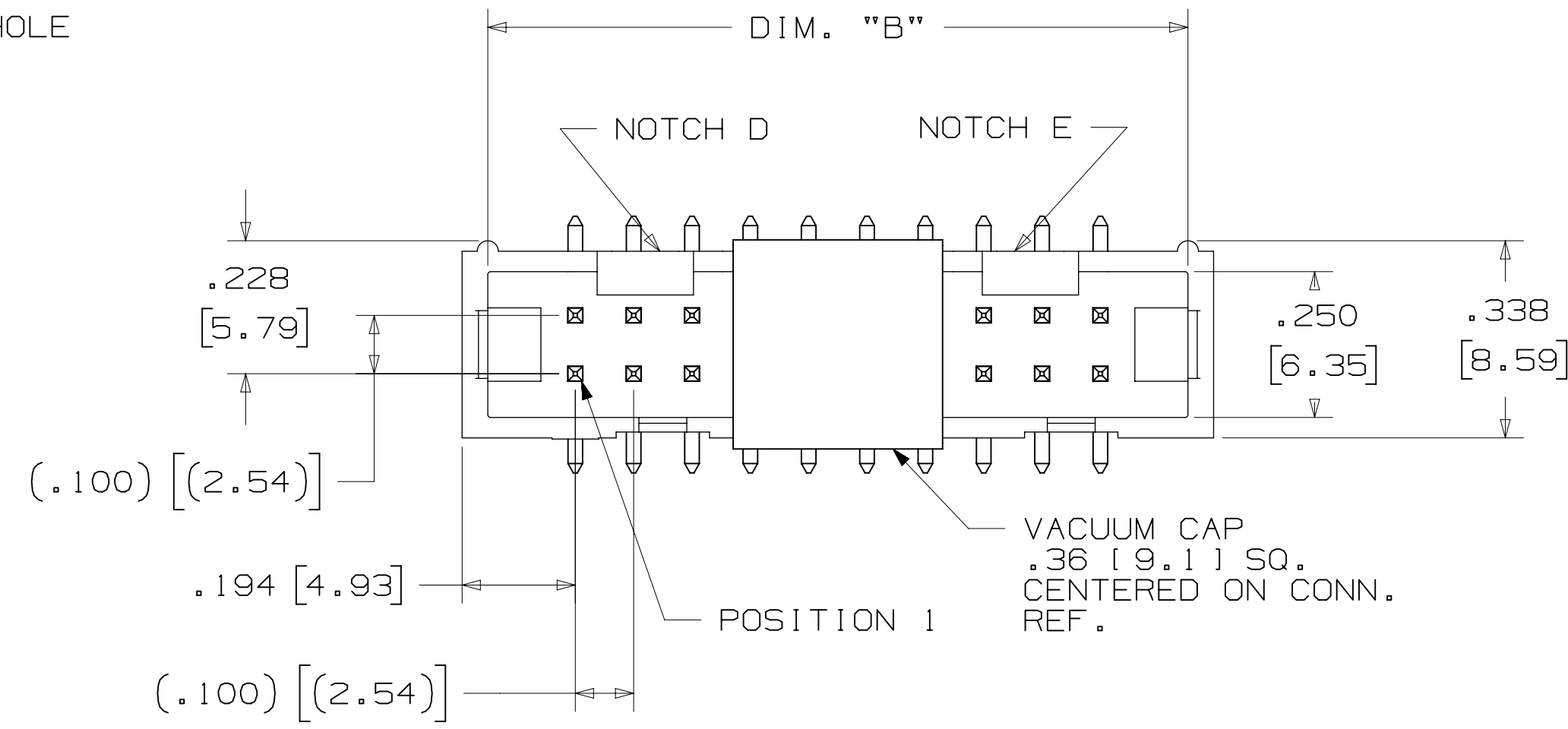
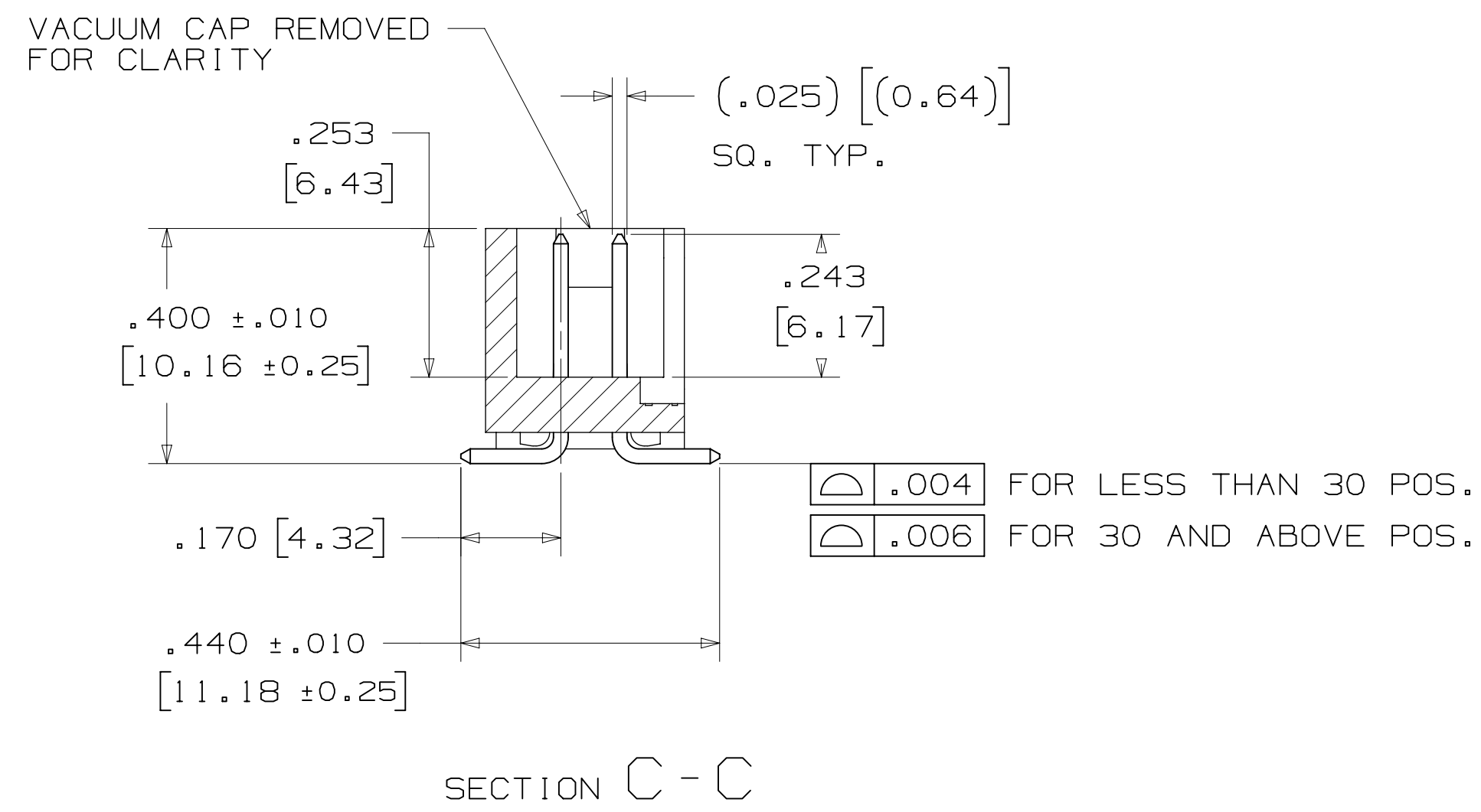
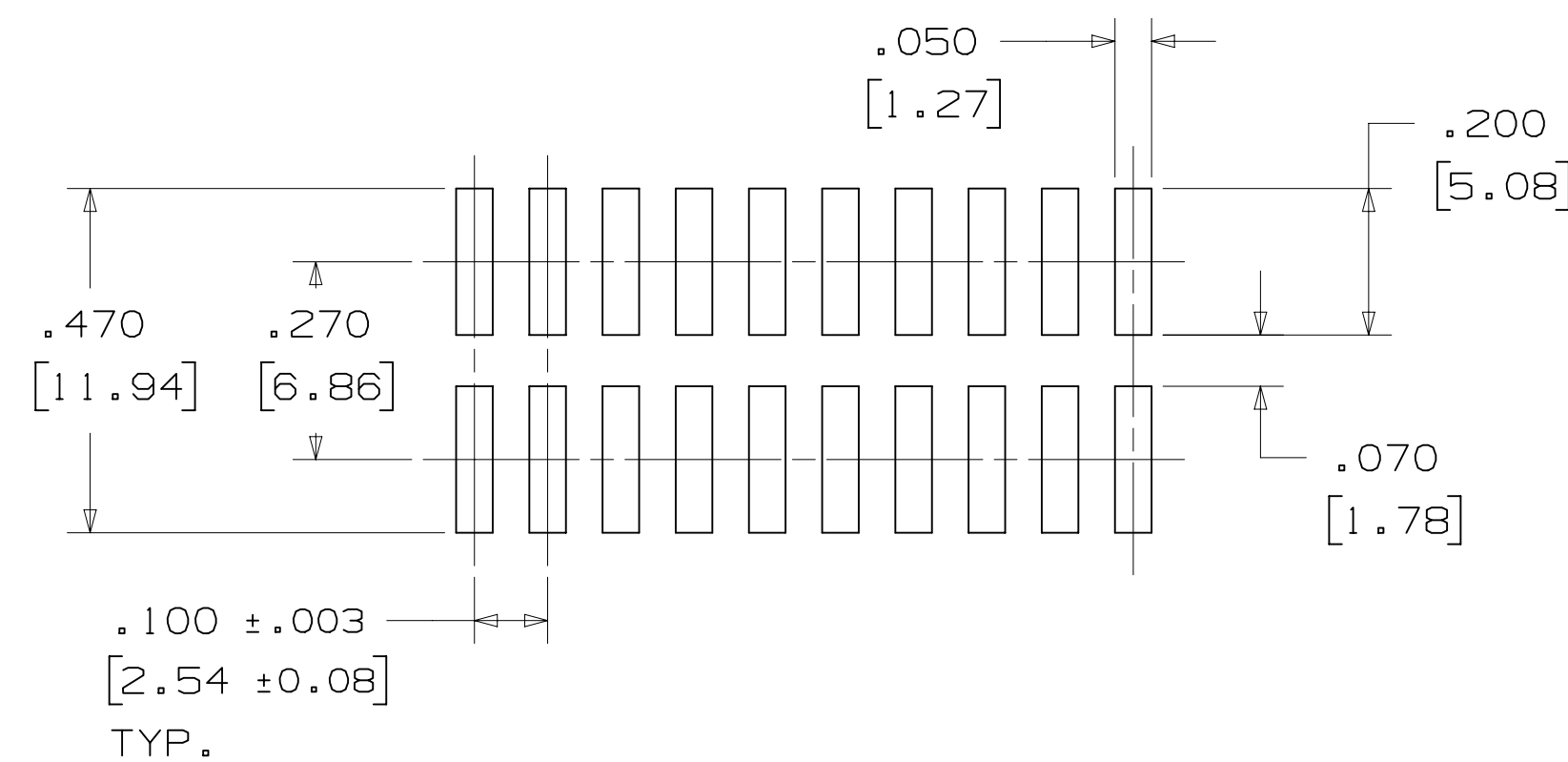
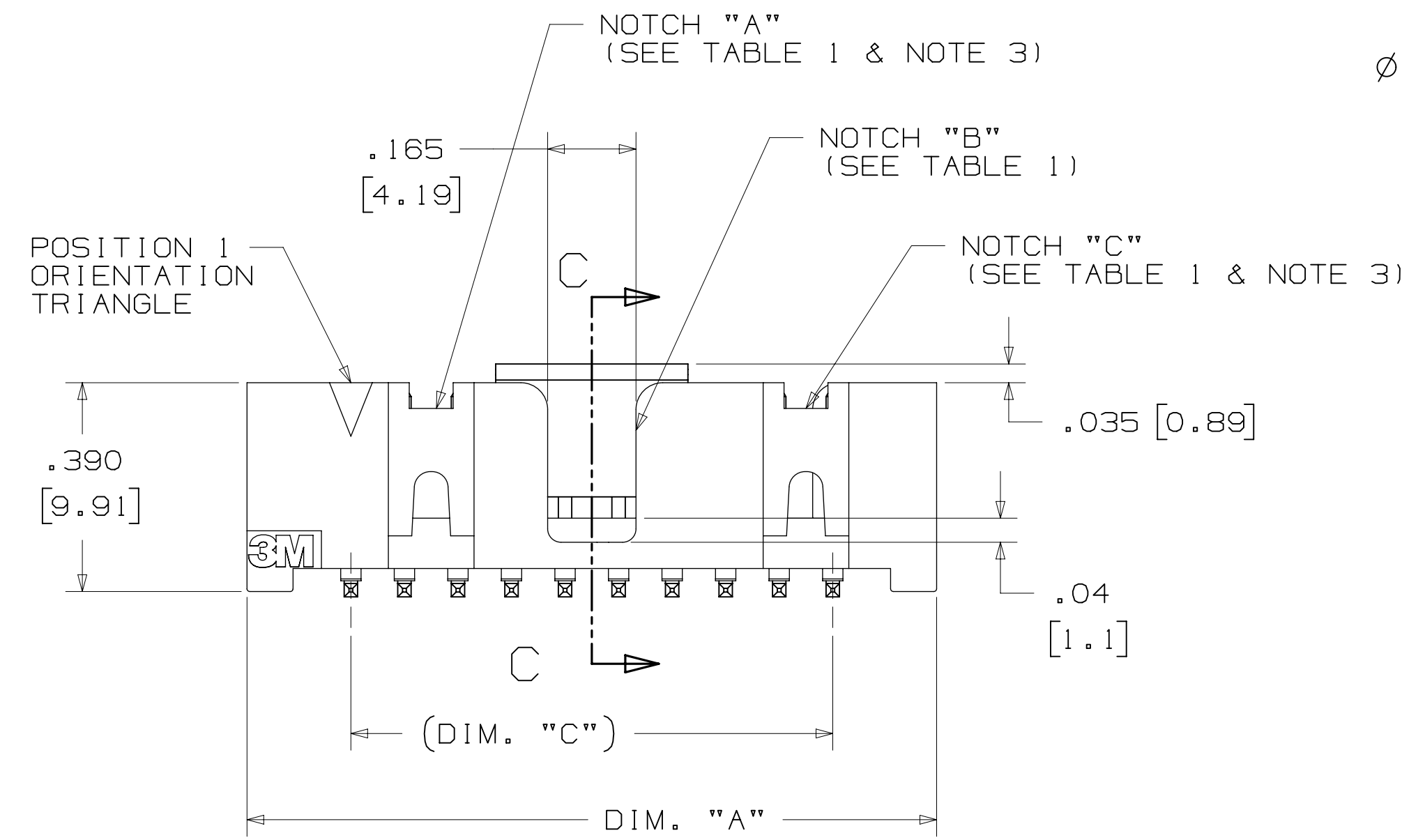

TABLE 1						
PIN QTY.	DIM. "A"	DIM. "B"	DIM. "C"	POLARIZING NOTCHES	TAPE AND REEL PKG CODE	PIN QTY.
06	.588 [14.94]	.508 [12.90]	.200 [5.08]	B	WD (44 MM)	06
08	.688 [17.48]	.608 [15.44]	.300 [7.62]	B	WD (44 MM)	08
10	.788 [20.02]	.708 [17.98]	.400 [10.16]	BC	WD (44 MM)	10
14	.988 [25.10]	.908 [23.06]	.600 [15.24]	BCDE	WD (44 MM)	14
16	1.088 [27.64]	1.008 [25.60]	.700 [17.78]	ABCDE	WD (44 MM)	16
20	1.288 [32.72]	1.208 [30.68]	.900 [22.86]	ABCDE	WE (56 MM)	20
24	1.488 [37.80]	1.408 [35.76]	1.100 [27.94]	ABCDE	WE (56 MM)	24
26	1.588 [40.34]	1.508 [38.30]	1.200 [30.48]	ABCDE	WE (56 MM)	26
30	1.788 [45.42]	1.708 [43.38]	1.400 [35.56]	ABCDE	WF (72 MM)	30
34	1.988 [50.50]	1.908 [48.46]	1.600 [40.64]	ABCDE	WF (72 MM)	34
36	2.088 [53.04]	2.008 [51.00]	1.700 [43.18]	ABCDE	WG (88 MM)	36
40	2.288 [58.12]	2.208 [56.08]	1.900 [48.26]	ABCDE	WG (88 MM)	40
50	2.788 [70.82]	2.708 [68.78]	2.400 [60.96]	ABCDE	WG (88 MM)	50
60	3.288 [83.52]	3.208 [81.48]	2.900 [73.66]	ABCDE	WH (120 MM)	60
64	3.488 [88.60]	3.408 [86.56]	3.100 [78.74]	ABCDE	WH (120 MM)	64



## ORDERING INFORMATION SURFACE MOUNT VERSION

X25XX-6VOC-XX-XX

N = RB PLATING REQ'D  
D = AR PLATING REQ'D

PIN QUANTITY:  
(SEE TABLE 1)

PACKAGING OPTIONS:  
WX = TAPE & REEL PACKAGING (SEE TABLE 1)

PLATING:  
AR = 10µ" [0.25µm] GOLD AVG.  
50µ-150µ [1.27µm-3.81µm] NICKEL UNDERPLATE  
40µ-120µ" [1.02µm-3.05µm] MATTE TIN (RIA, E1 & C1 APPLY)  
RB = 30µ" [0.76µm] GOLD AVG.  
50µ-150µ [1.27µm-3.81µm] NICKEL UNDERPLATE  
25µ-200µ" [0.63µm-5.08µm] MATTE TIN (RIA, E1 & C1 APPLY)

## RECOMMENDED PAD LAYOUT

DESIGN REFERENCE	NEXT ASSEMBLY	REV	ECO	ISSUE DATE AND DESCRIPTION	DRFT	CHKD
		P	89702	JUL 08, 2020 REVISE DRAWING PER NEW HEADER MODEL	JNC	SN
		N	68908	AUG 02, 2016 REVISE DIM ON SHT2 & CLIP CHART ON SHT5	JNC	SC
		M	56068	AUG 11, 2014 REVISED AND REDRAWN	JNC	RS
		REV	ECO	ISSUE DATE AND DESCRIPTION	DRFT	CHKD
		CHKD	CASTIGLIONE	AUG 11, 2014	DATE	DATE
		APPV	R. SCHERER	DATE	DATE	DATE
		APPROV	R. SCHERER	DATE	DATE	DATE
DIVISION: Interconnect Solutions		DIVISION CODE: EMSD				
DO NOT SCALE DRAWING	SCALE: 4/1	TOLERANCES EXCEPT AS NOTED				
THIRD ANGLE PROJECTION		INCHES: .00 ±.01, .000 ±.005, .0000 ±.0002				
INTERPRET PER ASME Y14.5 - 2018		MILLIMETERS: 0 ±.2, .00 ±.13, .000 ±.005				
MAX SURFACE ROUGHNESS: 12.5 SURFACES		CAGE NUMBER: D78-5100-0770-7				
MARKED ONLY		MODEL: 2500 SERIES				
		REV. P				
		SHT 4 OF 6				

**3M** Center St. Paul, MN 55144  
© 3M COPYR [GHT] 2020  
This document and the information it contains are 3M property and may not be reproduced or further distributed without 3M permission, or used or disclosed other than for 3M authorized purposes. All rights reserved.

HEADER, 4-WALL, LO-PRO, .100 X .100, SMT, STRAIGHT & RA

Imaged: Central Standard Time 9/14/2020 -- UTC Drt-set (hrs) 6

3M™ FOUR-WALL HEADER, 2500 SERIES  
 .100" X .100" LOW PROFILE, SURFACE MOUNT, STRAIGHT AND RIGHT ANGLE THROUGH-HOLE

PART CUSTOMIZATION

THIS SPEC SHEET DETAILS OUR STANDARD OFFERING.  
 3M HAS SEVERAL CAPABILITIES THAT CAN PROVIDE A PART TAILORED TO YOUR SPECIFIC NEEDS. ASK YOUR 3M SALES REPRESENTATIVE OR CUSTOMER SERVICE FOR MORE DETAILS.

- \* SELECTIVE PIN REMOVAL (FOR BOARD ASSEMBLY POLARIZATION).
- \* DIFFERENT PIN LENGTHS.

POLARIZING KEY

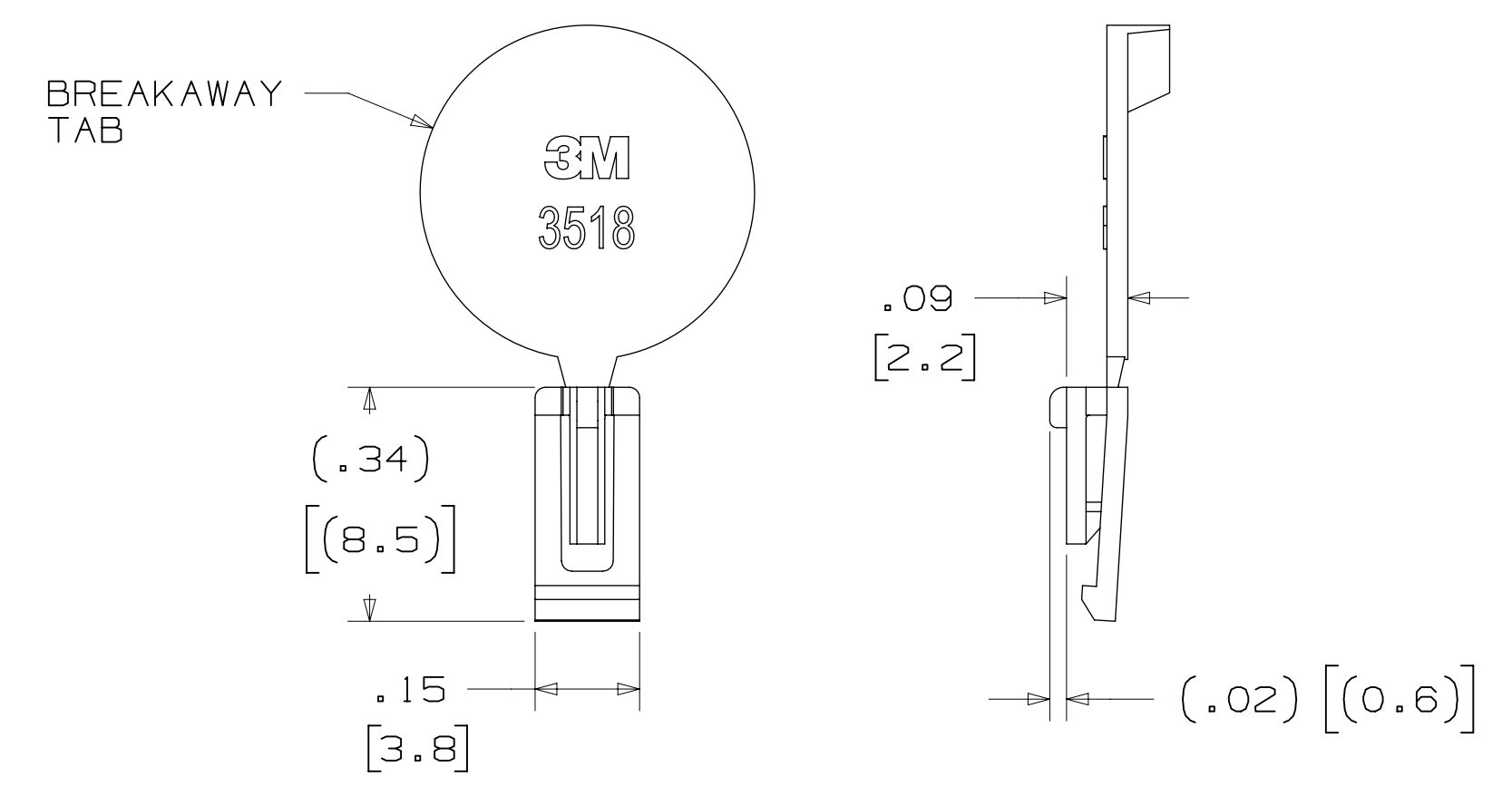

3M PART NO.	MATERIAL	COLOR
3518	PBT	GRAY
N3518	LCP	BLACK
D3518	PBT	BLACK

NOTE:  
 1) #2216 B/A SCOTCHWELD CAN BE USED TO ADHERE KEYS.  
 2) SEE INSTRUCTION SHEET 78-9100-7795-3 FOR ASSEMBLY.

LOW PROFILE LATCH

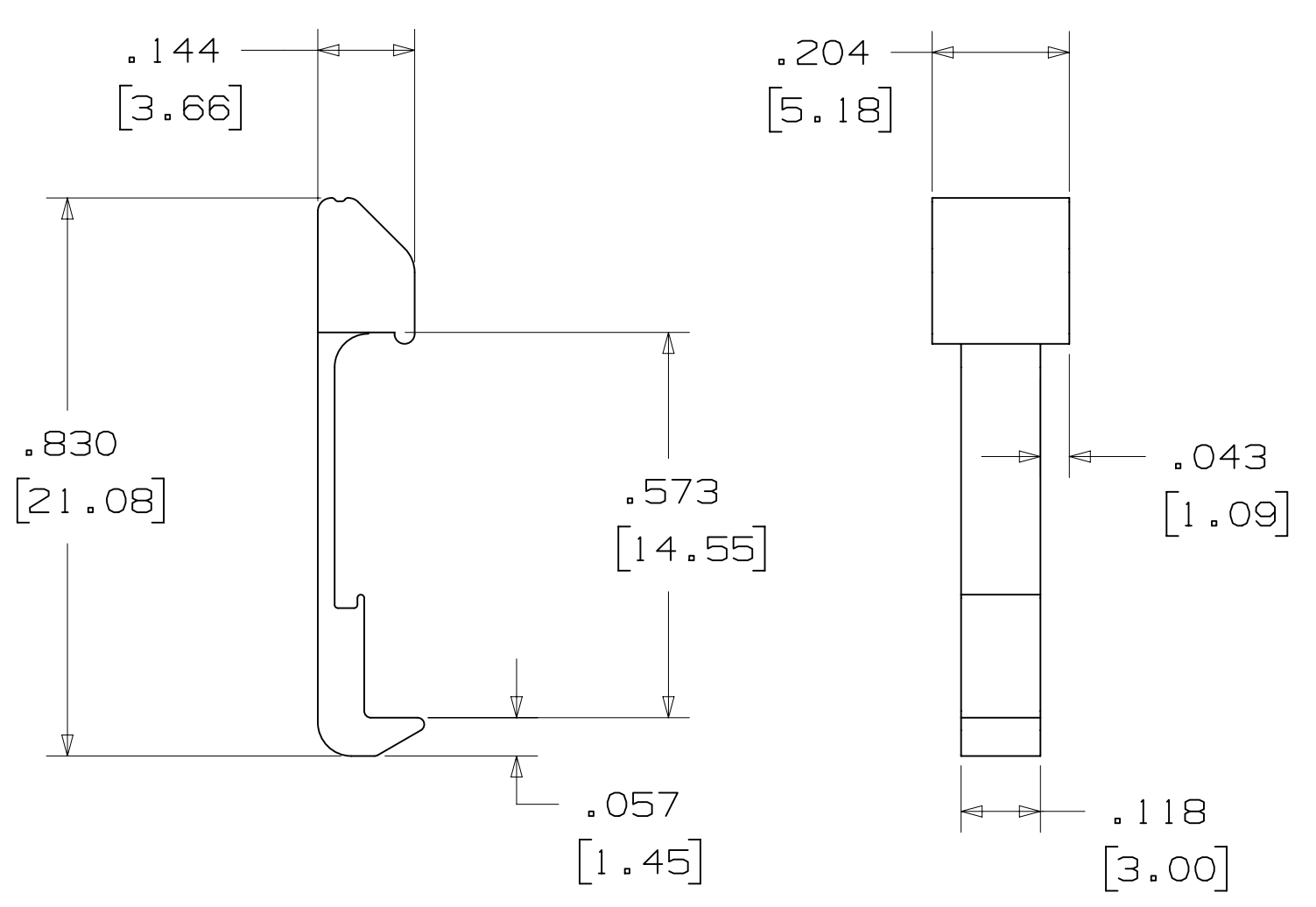

PART NO.	MATERIAL	COLOR
3505-33B	NYLON	BLACK

NOTE:  
 1. LATCHES NOT COMPATIBLE WITH REFLOW SOLDERING. ATTACH LATCHES AFTER SOLDERING.  
 2. LATCHES ARE MEANT FOR RETENTION ONLY.  
 3. SEE LAST SHEET FOR ASSEMBLY.

POLARIZING POST

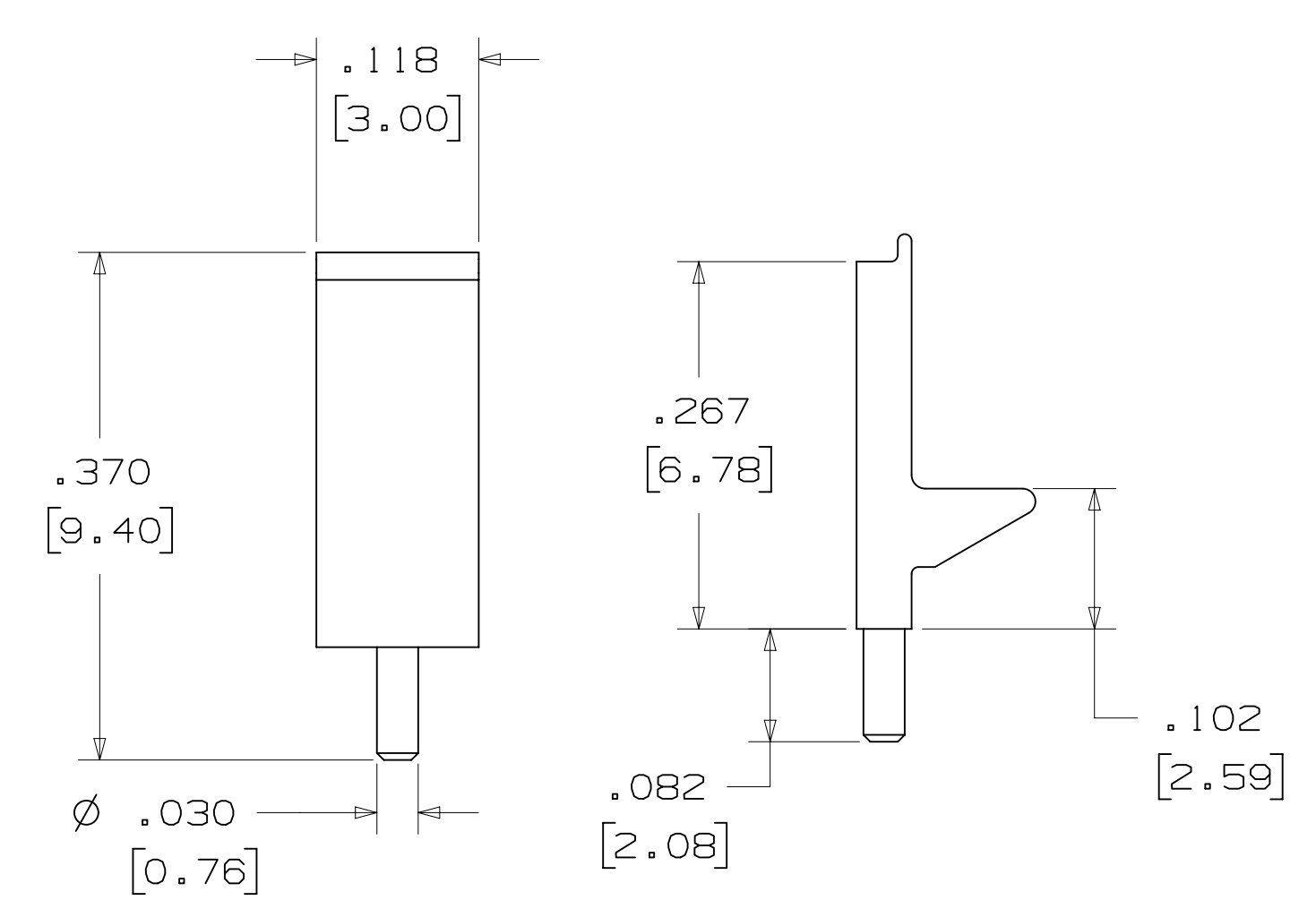

PART NO.	MATERIAL	COLOR
3201-3	PCT	BLACK

SHORT/LONG SOCKET RETAINER CLIP

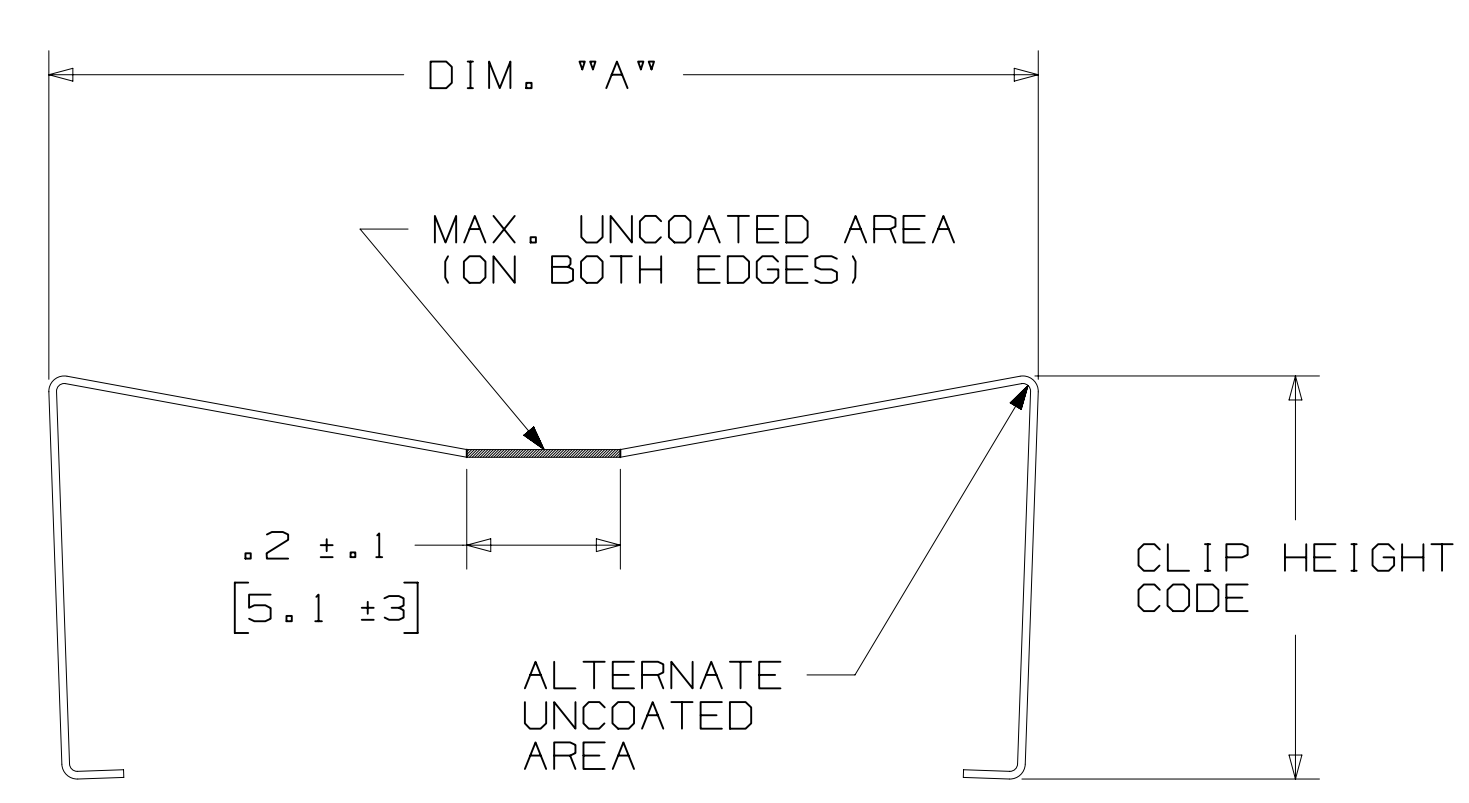

PIN QTY.	DIM. "A"
06	N/A
08	N/A
10	.81 [20.6]
14	1.02 [25.9]
16	1.12 [28.4]
20	1.32 [33.5]
24	1.52 [38.7]
26	1.63 [41.4]
30	1.83 [46.4]
34	2.03 [51.6]
36	N/A
40	2.33 [59.2]
50	2.83 [71.9]
60	3.33 [84.6]
64	3.53 [89.7]

NOTE:  
 STAINLESS STEEL WITH GRAY POLYURETHANE COATING.

3505-8XXX

CLIP HEIGHT CODE \_\_\_\_\_ PIN COUNT (SEE TABLE)  
 0 = .31 [7.9] FOR SOCKETS WITHOUT STRAIN RELIEF  
 1 = .53 [13.5] FOR SOCKETS WITH STRAIN RELIEF

NOTE:  
 1) THE FOLLOWING RETAINER CLIPS HAVE BEEN DISCONTINUED:  
 3505-8064  
 3505-8124  
 3505-8150

DESIGN REFERENCE	NEXT ASSEMBLY	REV	ECO	ISSUE DATE AND DESCRIPTION	DRFT	CHKD
ACROSS CODES		CASTIGLIONE		AUG 11, 2014		
DIVISION	DIVISION CODE	APPR	DATE	DATE		
Interconnect Solutions	EMSD	R. SCHERER		SEP 05, 2014		
DO NOT SCALE DRAWING	SCALE 4/1	TOLERANCES EXCEPT AS NOTED				
		INCHES: .0 ± .1, .00 ± .01, .000 ± .005, .0000 ± .0002				
		MILLIMETERS: 0 ± .2, .0 ± .13, .000 ± .005				
THIRD ANGLE PROJECTION	INTERPRET PER ASME Y14.5 - 2018	MAX SURFACE ROUGHNESS: SURFACES MARKED ONLY				
3M		© 3M COPYR [GHT] 2020. This document and the information it contains are 3M property and may not be reproduced or further distributed without 3M permission, or used or disclosed other than for 3M authorized purposes. All rights reserved.				
TITLE		HEADER, 4-WALL, LO-PRO, .100 X .100, SMT, STRAIGHT & RA				
CAGE NUMBER	SIZE	DRAWING NO.	REV.			
D		78-5100-0770-7	P			
MODEL	2500 SERIES	DET	IS1s	YES	NO	SHT 5 OF 6

P REVISION  
 78-5100-0770-7  
 DRAWING NUMBER  
 B  
 6  
 Drr-set (hrs)  
 -- UTC  
 Time 9/14/2020  
 Imaged: Central Standard

# 3M™ FOUR-WALL HEADER, 2500 SERIES

.100" X .100" LOW PROFILE, SURFACE MOUNT, STRAIGHT AND RIGHT ANGLE THROUGH-HOLE

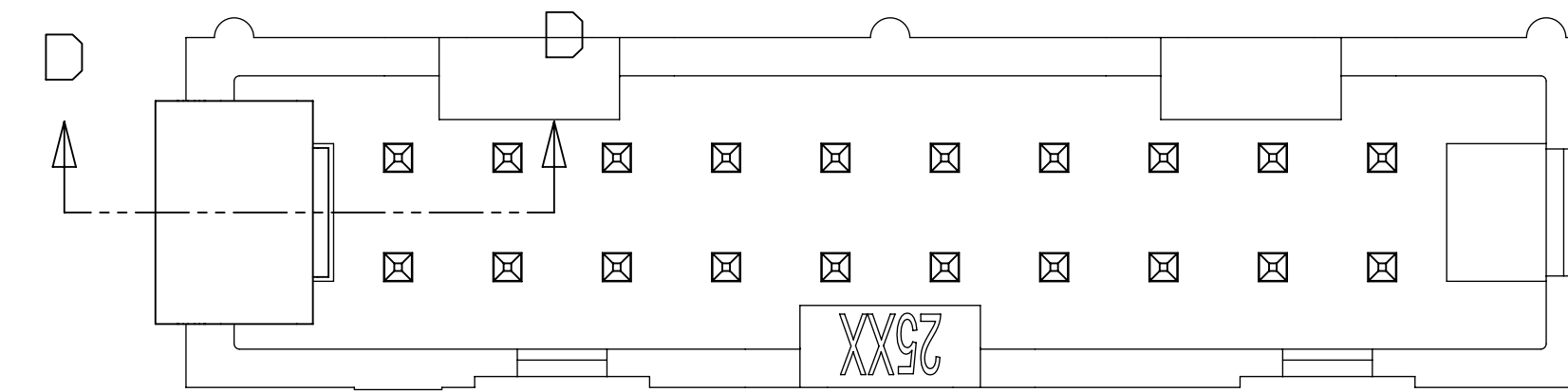

**Regulatory:** For regulatory information about this product, visit [3M.com/regs](http://3M.com/regs) or contact your 3M representative.

**Technical Information:** The technical information, recommendations and other statements contained in this document are based upon tests or experience that 3M believes are reliable, but the accuracy or completeness of such information is not guaranteed.

**Product Use:** Many factors beyond 3M's control and uniquely within user's control can affect the use and performance of a 3M product in a particular application. Given the variety of factors that can affect the use and performance of a 3M product, user is solely responsible for evaluating the 3M product and determining whether it is fit for a particular purpose and suitable for user's method of application.

**Warranty, Limited Remedy, and Disclaimer:** Unless an additional warranty is specifically stated on the applicable 3M product packaging or product literature, 3M warrants that each 3M product meets the applicable 3M product specification at the time 3M ships the product. 3M MAKES NO OTHER WARRANTIES OR CONDITIONS, EXPRESS OR IMPLIED, INCLUDING, BUT NOT LIMITED TO, ANY IMPLIED WARRANTY OR CONDITION OF MERCHANTABILITY OR FITNESS FOR A PARTICULAR PURPOSE OR ANY IMPLIED WARRANTY OR CONDITION ARISING OUT OF A COURSE OF DEALING, CUSTOM OR USAGE OR TRADE. If the 3M product does not conform to this warranty, then the sole and exclusive remedy is, at 3M's option, replacement of the 3M product or refund of the purchase price.

**Limitation of Liability:** Except where prohibited by law, 3M will not be liable for any loss or damage arising from the 3M product, whether direct, indirect, special, incidental or consequential, regardless of the legal theory asserted, including warranty, contract, negligence or strict liability.

3M Company  
 Electronics Materials Solutions Division  
 13011 McCallen Pass, Bldg. C  
 Austin, TX 78753-5380  
 1-800-225-5373  
[www.3M.com/interconnect](http://www.3M.com/interconnect)

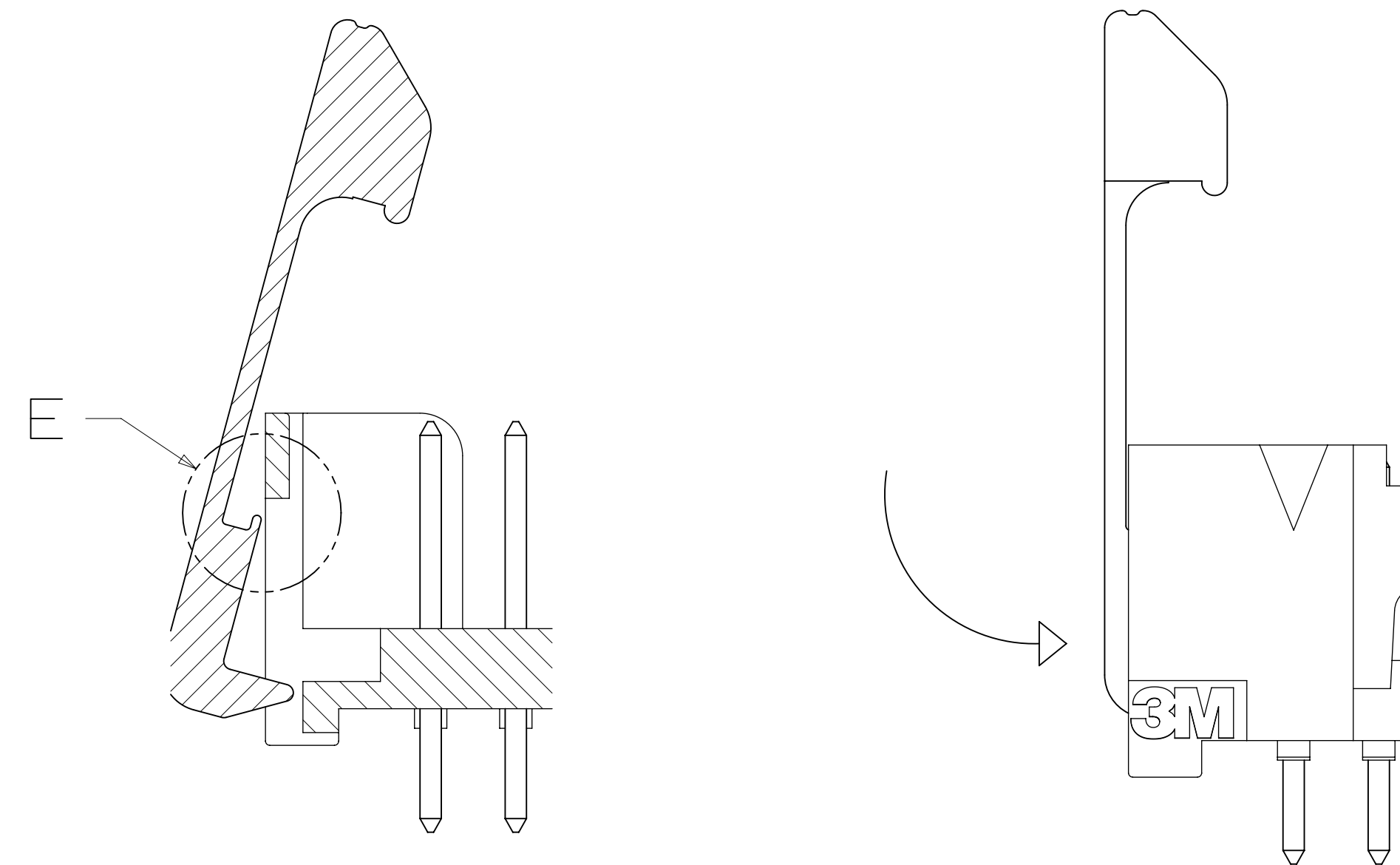

SECTION D-D  
 SCALE 6x

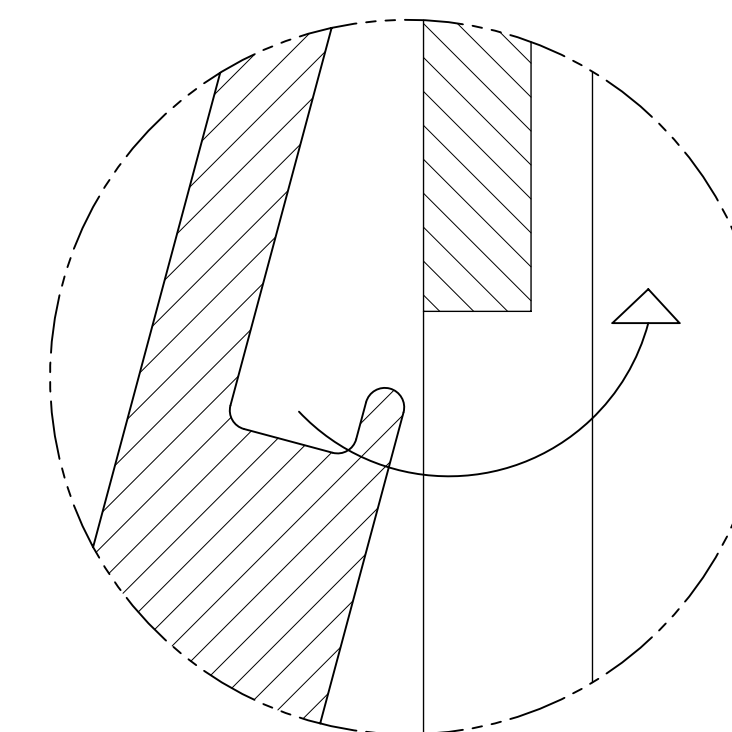

Detail E  
 SCALE 20x

TO ASSEMBLE LATCH:  
 PLACE LIP UNDER OPENING IN END WALL.  
 PRESS INTO END WALL UNTIL LATCH CLICKS.

REV	ECO	ISSUE DATE AND DESCRIPTION	DRFT	CHKD
P	89702	JUL 08, 2020 REVISE DRAWING PER NEW HEADER MODEL	JNC	SN
N	68908	AUG 02, 2016 REVISE DIM ON SHT2 & CLIP CHART ON SHT5	JNC	SC
M	56068	AUG 11, 2014 REVISED AND REDRAWN	JNC	RS

DESIGN REFERENCE	NEXT ASSEMBLY	REV	ECO	ISSUE DATE AND DESCRIPTION	DRFT	CHKD
				AUG 11, 2014		

DIVISION	DIVISION CODE	DATE	DATE
Interconnect Solutions	EMSD	AUG 11, 2014	SEP 05, 2014

DO NOT SCALE DRAWING	SCALE	TOLERANCES EXCEPT AS NOTED
	6 1	

INCHES	MILLIMETERS
.0	± .1
.00	± .01
.000	± .005
.0000	± .0002
0	± 2
.0	± .3
.00	± .13
.000	± .005

MAX SURFACE ROUGHNESS	DEF SURFACES	MARKED ONLY	ANGLES

MODEL	SIZE	DRAWING NO.	REV.
2500 SERIES		D78-5100-0770-7	P

DATE	DATE	DATE
AUG 11, 2014	SEP 05, 2014	

3M	St. Paul, MN 55144	© 3M COPYRIGHT 2020
		This document and the information it contains are 3M property and may not be reproduced or further distributed without 3M permission, or used or disclosed other than for 3M authorized purposes. All rights reserved.

TITLE	CAGE NUMBER	SIZE	DRAWING NO.	REV.
HEADER, 4-WALL, LO-PRO, .100 X .100, SMT, STRAIGHT & RA	D		78-5100-0770-7	P

MODEL	SIZE	DRAWING NO.	REV.
2500 SERIES		D78-5100-0770-7	P

P REVISION  
 78-5100-0770-7  
 DRAWING NUMBER  
 B  
 C  
 D  
 A  
 Time 9/14/2020 -- UTC  
 Drf-set (hrs) 6  
 Imaged: Central Standard